

COMPUSTAR®

INSTALL GUIDE

2012-2015 SCION IQ 80-BIT STD KEY AT



DOCUMENT NUMBER

REVISION DATE

20180926

FIRMWARE

COM-RSA-TL5-[RS1B-DC3]

HARDWARE

RS1B-DC3

ACCESSORIES

ATTENTION: TO COMPLETE THIS INSTALLATION SOME ACCESSORIES MAY BE REQUIRED. VISIT OUR WEBSITE TO SEE ALL THE REQUIRED ACCESSORIES FOR YOUR VEHICLE.

TERMS OF USE

Automotive Data Solutions Inc. ("ADS") products are strictly intended for installation by Certified Technicians who are employed by a registered business specialized in the installation of automotive aftermarket electronics products. Prior to beginning installation of an ADS product in a vehicle, it is the Certified Technician's responsibility to review the most current Product Guide, Install Guide and vehicle-specific notes available in Weblink®. ADS is not responsible for any damages whatsoever, including but not limited to any consequential damages, incidental damages, damages for loss of time, loss of earnings, loss of profit, commercial loss, loss of economic opportunity and the like that may or may not have resulted from the use, misuse, improper installation or operation of its products. ADS reserves itself the right to suspend any Weblink® account without notice and decline to offer technical support to non-Certified Technicians, non-compliant Certified Technicians or end users.

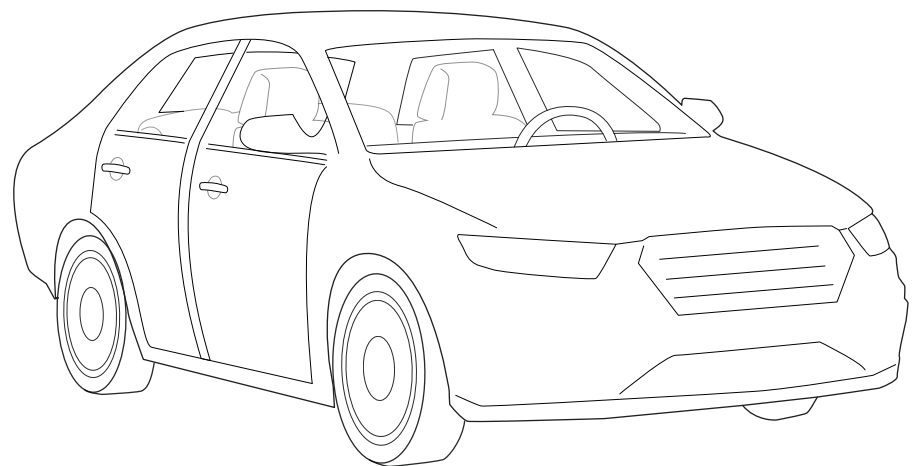
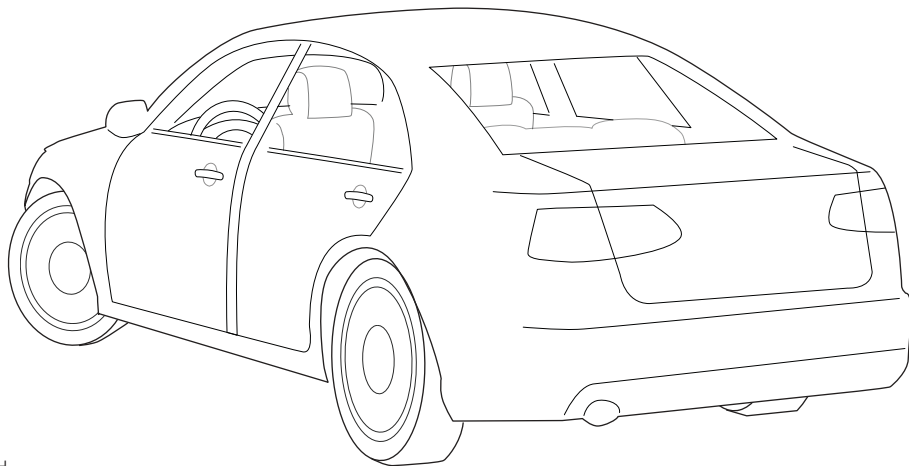
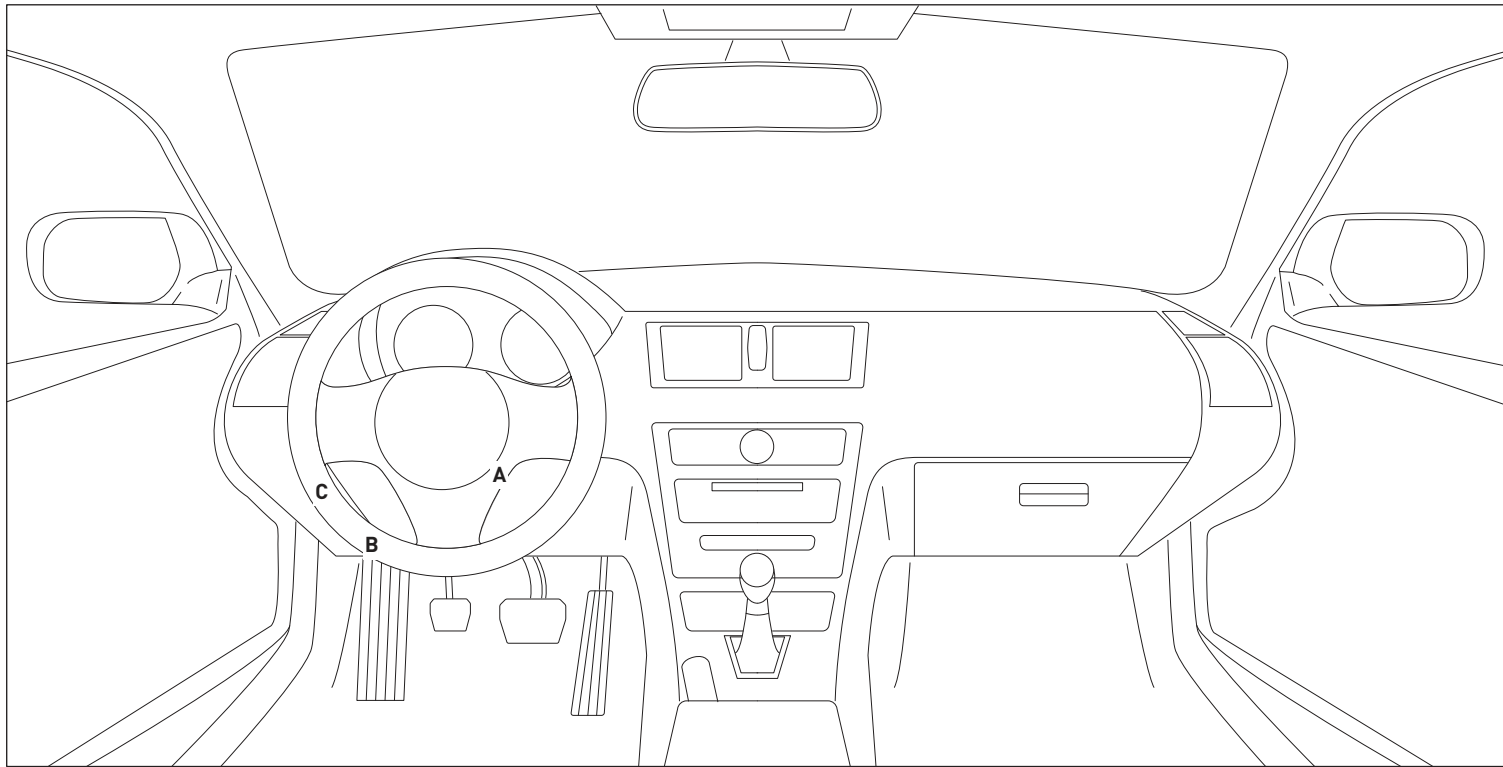

- CUT LOOP FOR AUTOMATIC TRANSMISSION ONLY
- SOME PARTS OF THE T-HARNESS (MS4-C, MS2-A, VS3/VS4 AND JS8) ARE NOT USED IN THIS INSTALL DO NOT CONNECT THEM.
- JS7 IS NOT USED IF THE VEHICLE IS EQUIPPED WITH AN IMMOBILIZER

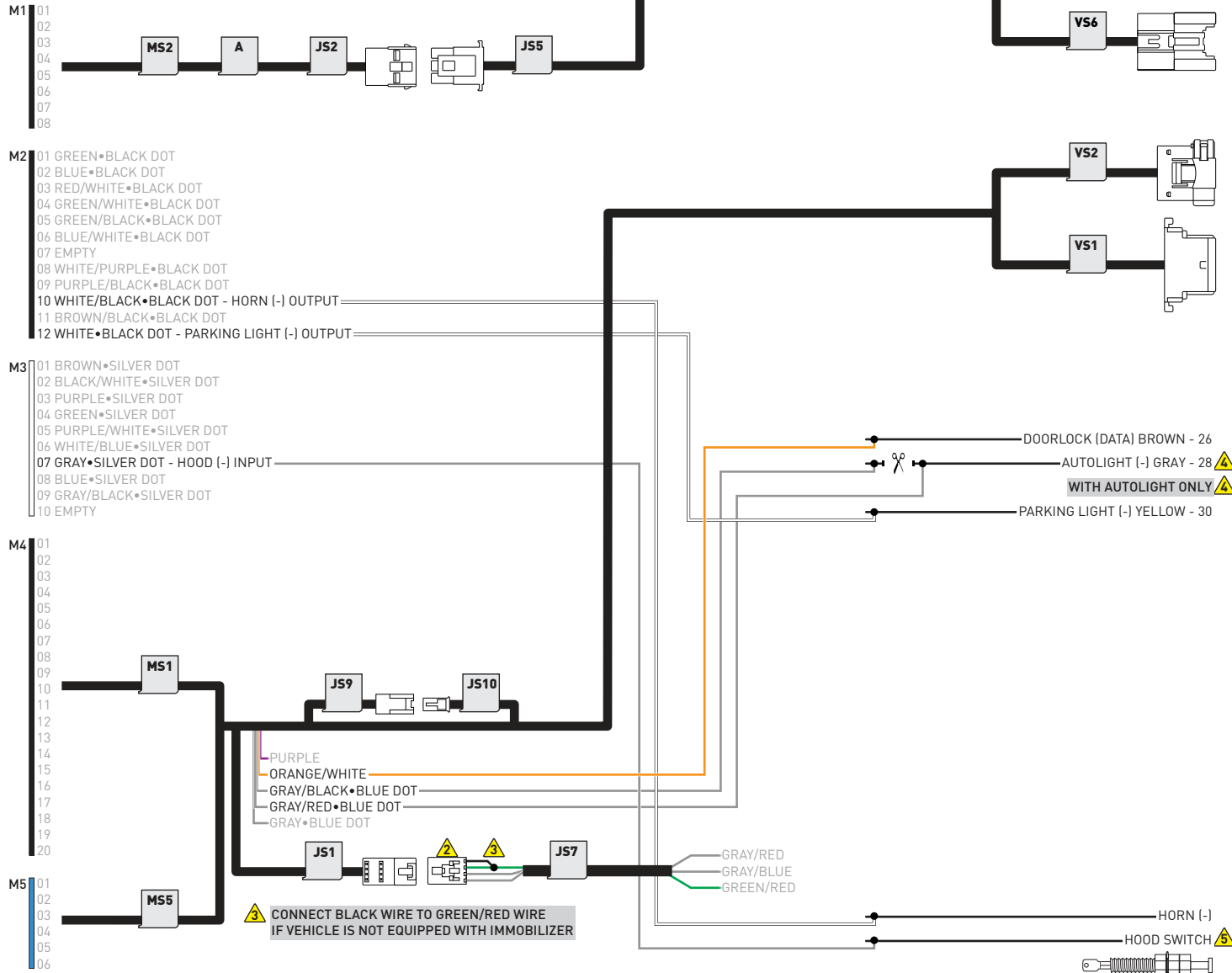

CONNECT BLACK WIRE TO GREEN/RED WIRE IF VEHICLE IS NOT EQUIPPED WITH IMMOBILIZER

IF NOT EQUIPPED WITH AN OEM HOOD PIN:
- INSTALL THE SUPPLIED HOOD SWITCH.
 - CHANGE REMOTE STARTER INPUT CONFIGURATION (MENU #7) "4- HOOD INPUT SOURCE" TO "1- ANALOG".

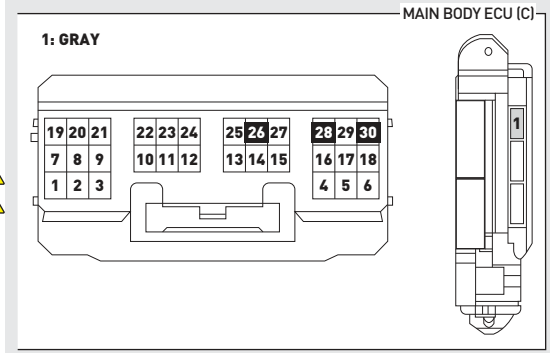
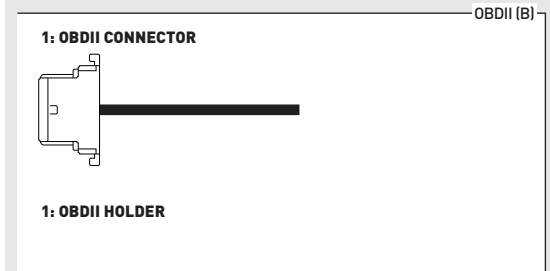
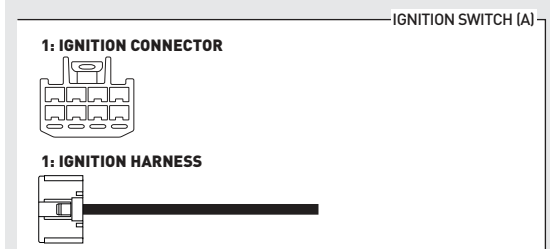

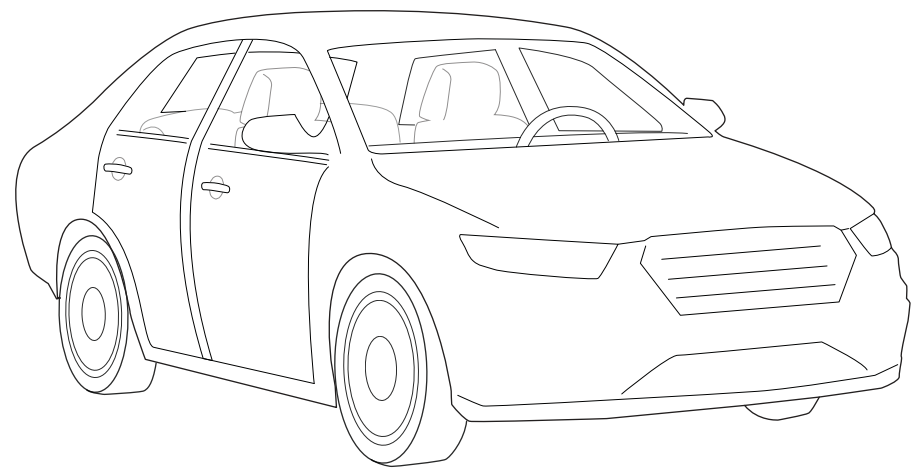
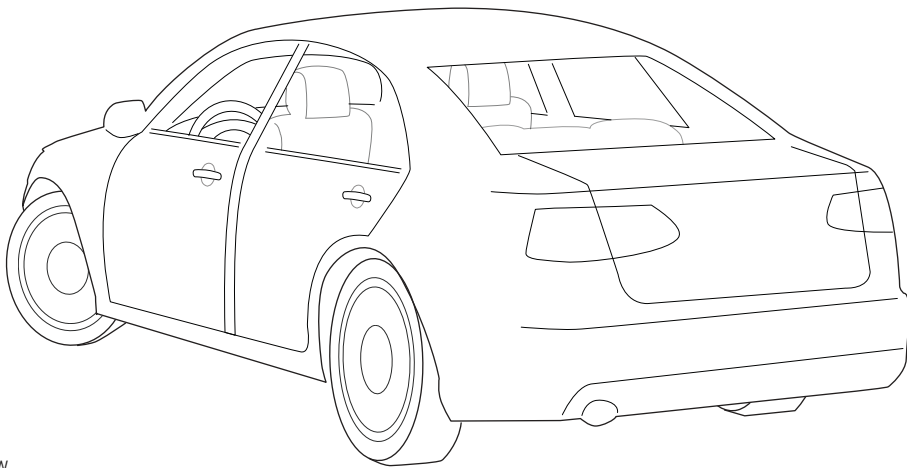
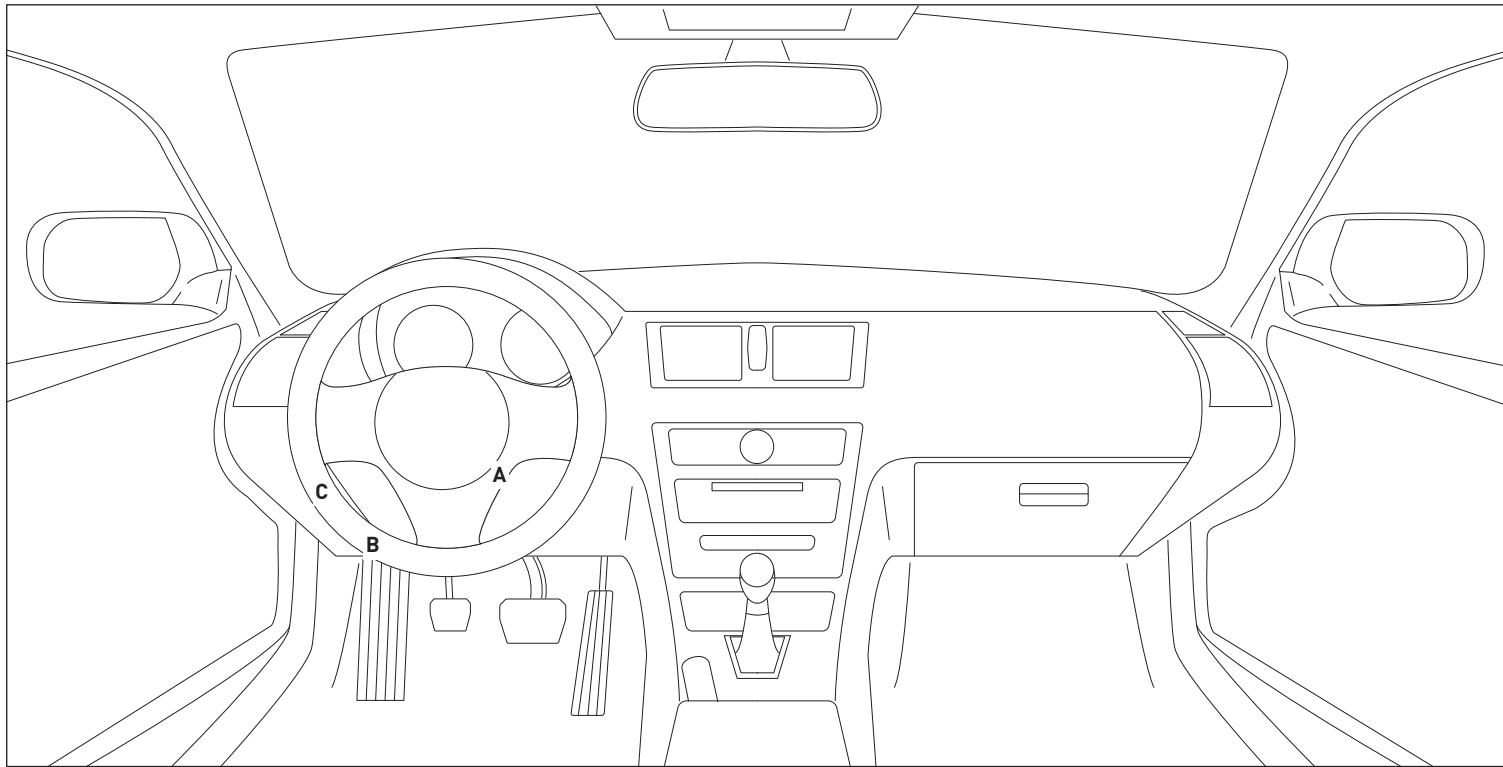

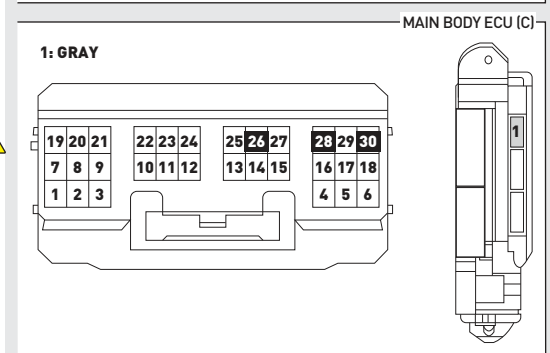
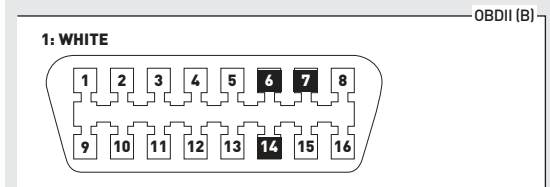
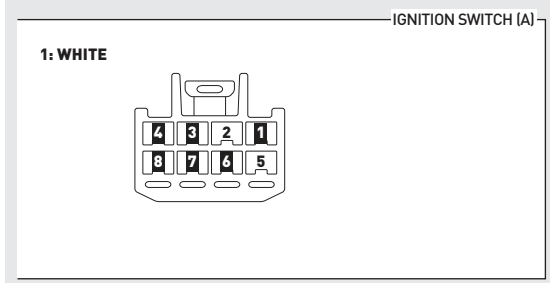
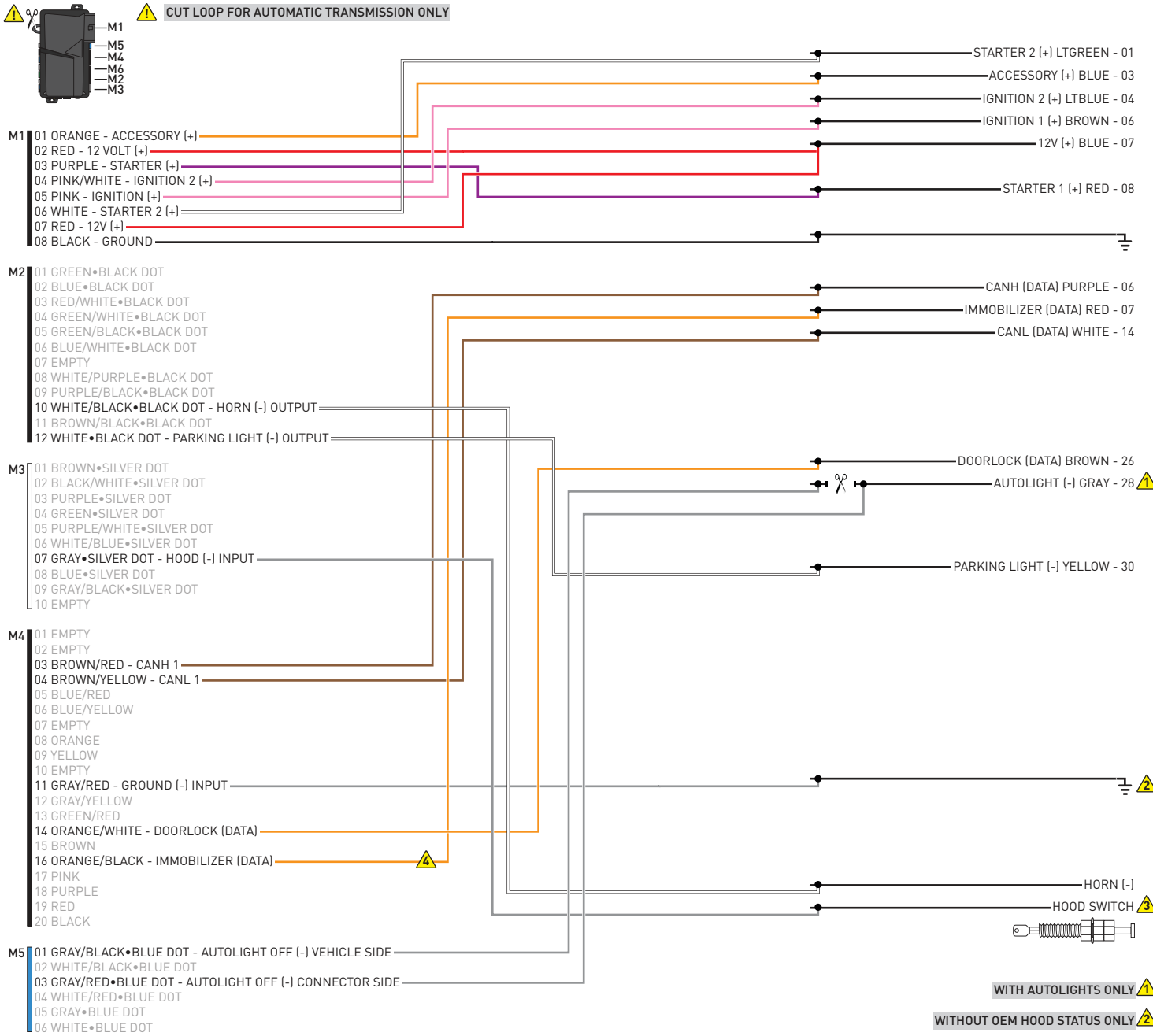

WITH AUTOLIGHTS ONLY ⚠

WITHOUT OEM HOOD STATUS ONLY ⚠

INSTALL THE SUPPLIED HOOD SWITCH IF THE VEHICLE IS NOT EQUIPPED WITH ONE. ⚠

CONNECT ORANGE/BLACK WIRE TO GROUND IF VEHICLE IS NOT EQUIPPED WITH IMMOBILIZER ⚠

01  Use the BLACK key only. DO NOT use the GRAY valet key.

02  Turn key to ON position.

03  Wait, LED 1 will turn solid GREEN for 2 seconds.

04  Turn key to OFF position.

05  START vehicle for 15 seconds.

06  Press and hold the brake pedal.

07  Press and release the module's programming button.

08  Release the brake pedal.

09  Wait, LED 2 will flash GREEN.

10  Module Programming Procedure completed.

>>



All vehicle doors must be closed and locked prior to remote start sequence.

01



Press unlock on OEM or aftermarket remote or request switch.

02



DO NOT PRESS BRAKE PEDAL. Set ignition to ON position. Wait 2 seconds for key validation.

03



Press and release BRAKE pedal.

04



Take over procedure completed.

>>



Failure to follow procedure will result in vehicle engine shutdown.

CHECKLIST - WITH AFTERMARKET KEYFOB

1	WARNING: Vehicle engine will start many times. Test in a well ventilated area.	9	Press the START/STOP button once [1x] on the aftermarket keyfob to shut down vehicle.
2	Close all vehicle doors, hood and trunk.		Question 7: Does the vehicle shut down?
3	Press the LOCK button once [1x] on the aftermarket keyfob.	<input type="checkbox"/>	YES: Go to next step.
	Question 1: Do the doors lock?	<input type="checkbox"/>	NO: Repeat step. If problem persists, press the brake pedal once [1x] to shut down the vehicle and call technical support.
<input type="checkbox"/>	YES: Go to next step.	10	RAP and auto light shutdown test
<input type="checkbox"/>	NO: Verify the remote programming, the RF connections and the wired door lock/unlock connections as illustrated in the wiring diagram, if applicable. Repeat the test and call technical support, if the problem persists.		Question 8: Did the radio, interior controls and headlights turn off within 60 seconds after remote start shutdown?
4	Press the UNLOCK button once [1x] on the aftermarket keyfob.	<input type="checkbox"/>	YES: Go to next step.
	Question 2: Do the doors unlock?	<input type="checkbox"/>	NO: Verify the RAP SHUTDOWN connections as illustrated in the wiring diagram. Repeat the test and call technical support if the problem persists.
<input type="checkbox"/>	YES: Go to next step.	11	Open hood.
<input type="checkbox"/>	NO: Verify the remote programming, the RF connections and the wired door lock/unlock connections as illustrated in the wiring diagram, if applicable. Repeat the test and call technical support, if the problem persists.	12	If not already installed, affix the mandatory orange warning sticker under the hood and proceed to next step.
5	Press the TRUNK release button once [1x] on the aftermarket keyfob if supported.	13	Press the START/STOP button once [1x] on the aftermarket keyfob to remote start vehicle.
	Question 3: Does the trunk or hatch open/unlock?		Question 9: Does the vehicle remote start?
<input type="checkbox"/>	YES: Close trunk or hatch and go to next step.	<input type="checkbox"/>	YES: The vehicle is not equipped with a factory hood pin. Install a mandatory aftermarket hood switch, then repeat the test.
<input type="checkbox"/>	NO: Verify the remote programming, the RF connections and the wired trunk/hatch connections as illustrated in the wiring diagram, if applicable. Repeat the test and call technical support, if the problem persists.	<input type="checkbox"/>	NO: Go to next step.
6	Press the AUX 1 button once [1x] on the aftermarket keyfob if supported.	14	Close hood.
	Question 4: Does the driver side sliding door open?	15	Enter vehicle and close the doors.
<input type="checkbox"/>	YES: Press the AUX 1 button once [1x] to close the driver sliding door and go to next step.	16	Press the START/STOP button once [1x] on the aftermarket keyfob to remote start vehicle.
<input type="checkbox"/>	NO: Verify the remote programming and the RF connections. Repeat the test and call technical support, if the problem persists.	17	Wait for the vehicle to start.
7	Press the AUX 2 button once [1x] on the aftermarket keyfob if supported.	18	Press brake pedal.
	Question 5: Does the passenger side sliding door open?		Question 10: Does the vehicle shut down?
<input type="checkbox"/>	YES: Press the AUX 2 button once [1x] to close the passenger sliding door and go to next step.	<input type="checkbox"/>	YES: Go to next step.
<input type="checkbox"/>	NO: Verify the remote programming and the RF connections. Repeat the test and call technical support, if the problem persists.	<input type="checkbox"/>	NO: The module does NOT detect the brake pedal signal. Press the START/STOP button once [1x] on the aftermarket keyfob to shut down vehicle, check connection as illustrated in the wiring diagram, if applicable, and call technical support.
8	Press the START/STOP button once [1x] on the aftermarket keyfob to remote start vehicle.	19	Exit vehicle.
	Question 6: Does the vehicle remote start?	20	Installation checklist completed.
<input type="checkbox"/>	YES: Go to next step.		
<input type="checkbox"/>	NO: Verify the remote programming, the RF connections and check the remote start error codes. Repeat the test and call technical support, if the problem persists.		

CHECKLIST - WITH OEM KEYFOB	
1	WARNING: Vehicle engine will start many times. Test in a well ventilated area.
2	Close all vehicle doors, hood and trunk.
3	Press LOCK button three times [3x] rapidly on the OEM keyfob to remote start vehicle.
	Question 1: Does the vehicle remote start?
<input type="checkbox"/>	YES: Go to next step.
<input type="checkbox"/>	NO: The module doesn't detect OEM remote lock button from the vehicle communication network. Check all connections, repeat the test and call technical support, if the problem persists.
4	Press LOCK button three times [3x] rapidly on the OEM keyfob to shut down vehicle.
	Question 2: Does the vehicle shut down?
<input type="checkbox"/>	YES: Go to next step.
<input type="checkbox"/>	NO: Repeat step. If the problem persists, press on the brake pedal once [1x] to shut down the vehicle and call technical support.
5	RAP Shutdown test
	Question 3: Did the radio, interior controls, and headlights turn off within 60 seconds after remote start shutdown?
<input type="checkbox"/>	YES: Go to next step.
<input type="checkbox"/>	NO: Verify the RAP SHUTDOWN connections as illustrated in the wiring diagram. Repeat the test and call technical support, if the problem persists.
6	Open hood.
7	If not already installed, affix the mandatory orange warning sticker under the hood and proceed to next step.
8	Press LOCK button three times [3x] rapidly on the OEM keyfob to remote start vehicle.
	Question 4: Does the vehicle remote start?
<input type="checkbox"/>	YES: The vehicle is not equipped with a factory hood pin. Install a mandatory aftermarket hood switch, then repeat the test.
<input type="checkbox"/>	NO: Go to next step.
9	Close hood.
10	Enter vehicle and close the doors.
11	Press LOCK button three times [3x] rapidly on the OEM keyfob to remote start vehicle.
12	Wait for the vehicle to start.
13	Press brake pedal.
	Question 5: Does the vehicle shut down?
<input type="checkbox"/>	YES: Go to next step.
<input type="checkbox"/>	NO: The module does NOT detect the brake pedal signal. Press LOCK button three times [3x] rapidly on the OEM keyfob to shut down, check the brake connection as illustrated in the wiring diagram, if applicable, and call technical support.
14	Exit vehicle.
15	Installation checklist completed.

COMPUSTAR®

INSTALL GUIDE

2011-2016 SCION TC 80-BIT STD KEY AT



DOCUMENT NUMBER

REVISION DATE

20180926

FIRMWARE

COM-RSA-TL5-[RS1B-DC3]

HARDWARE

RS1B-DC3

ACCESSORIES

ATTENTION: TO COMPLETE THIS INSTALLATION SOME ACCESSORIES MAY BE REQUIRED. VISIT OUR WEBSITE TO SEE ALL THE REQUIRED ACCESSORIES FOR YOUR VEHICLE.

TERMS OF USE

Automotive Data Solutions Inc. ("ADS") products are strictly intended for installation by Certified Technicians who are employed by a registered business specialized in the installation of automotive aftermarket electronics products. Prior to beginning installation of an ADS product in a vehicle, it is the Certified Technician's responsibility to review the most current Product Guide, Install Guide and vehicle-specific notes available in Weblink®. ADS is not responsible for any damages whatsoever, including but not limited to any consequential damages, incidental damages, damages for loss of time, loss of earnings, loss of profit, commercial loss, loss of economic opportunity and the like that may or may not have resulted from the use, misuse, improper installation or operation of its products. ADS reserves itself the right to suspend any Weblink® account without notice and decline to offer technical support to non-Certified Technicians, non-compliant Certified Technicians or end users.

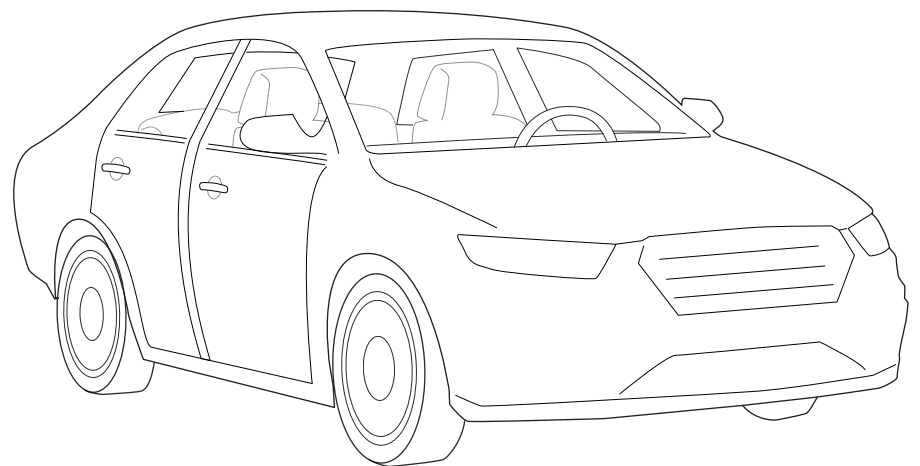
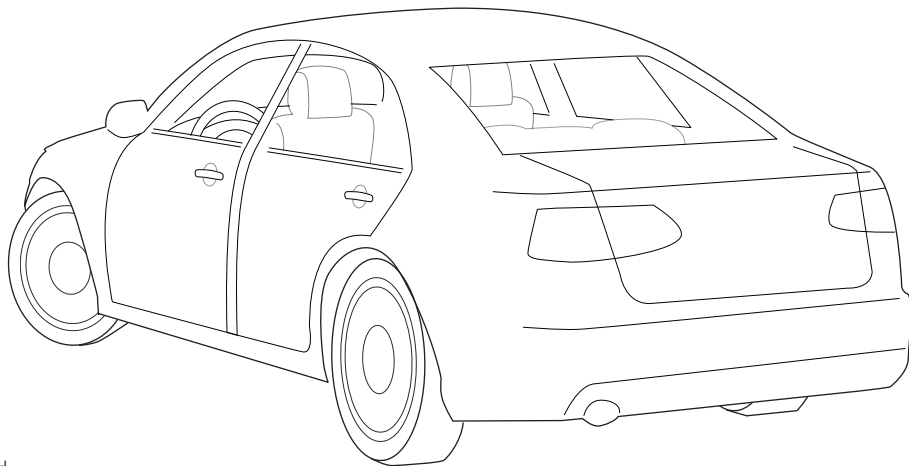
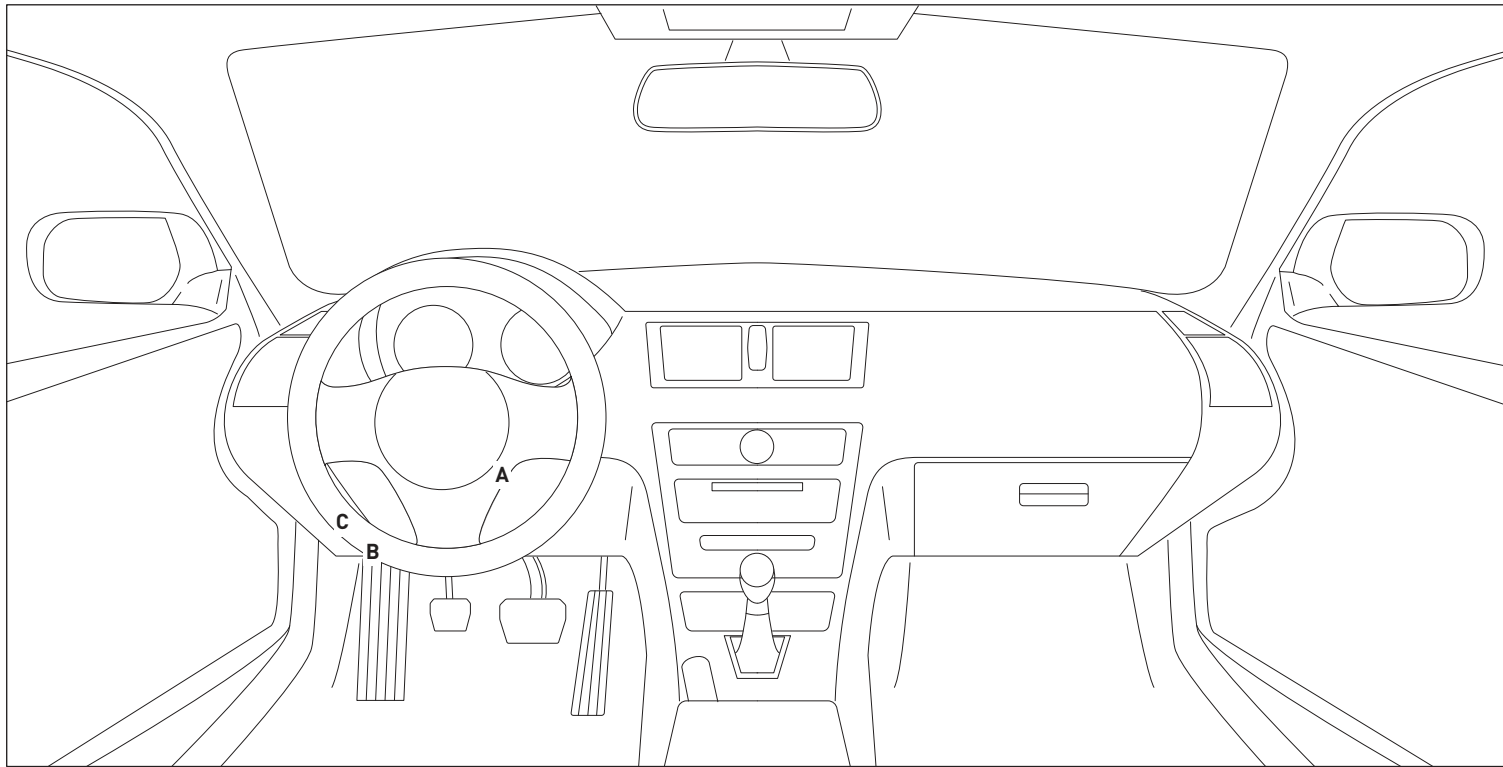

- CUT LOOP FOR AUTOMATIC TRANSMISSION ONLY
- SOME PARTS OF THE T-HARNESS (MS4-C, MS2-A, VS3/VS4 AND JS8) ARE NOT USED IN THIS INSTALL DO NOT CONNECT THEM.
- JS7 IS NOT USED IF THE VEHICLE IS EQUIPPED WITH AN IMMOBILIZER

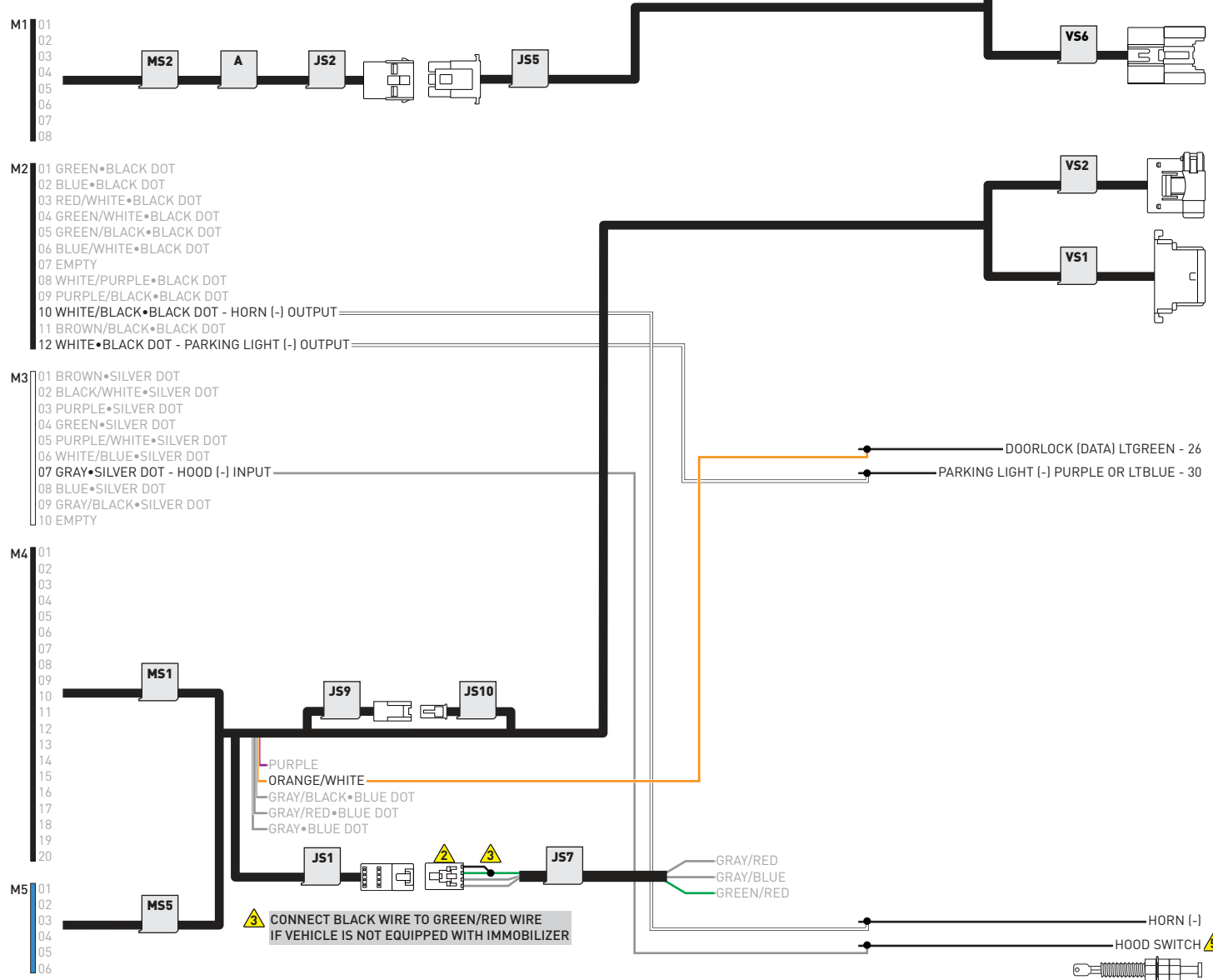

CONNECT BLACK WIRE TO GREEN/RED WIRE IF VEHICLE IS NOT EQUIPPED WITH IMMOBILIZER

IF NOT EQUIPPED WITH AN OEM HOOD PIN:
 - INSTALL THE SUPPLIED HOOD SWITCH.
 - CHANGE REMOTE STARTER INPUT CONFIGURATION (MENU #7) "4- HOOD INPUT SOURCE" TO "1- ANALOG".

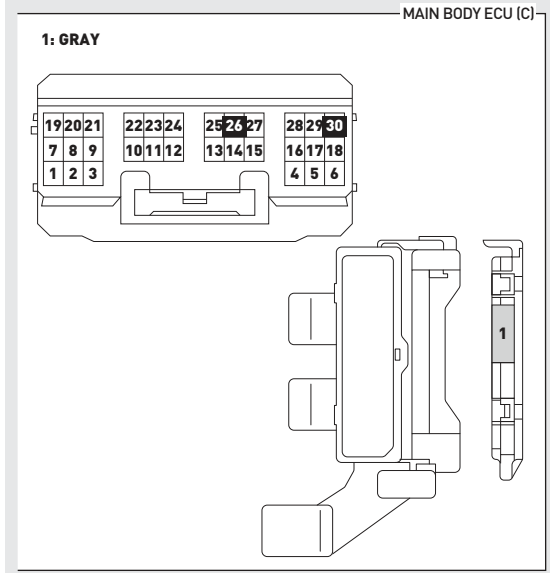
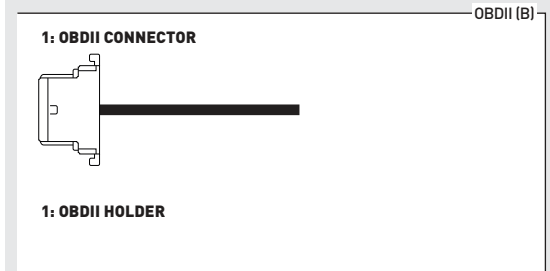
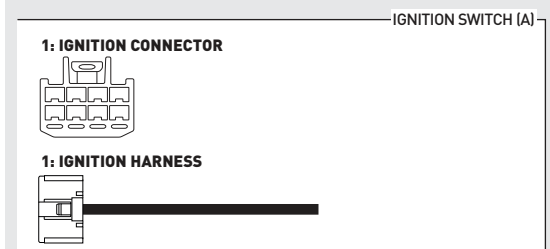

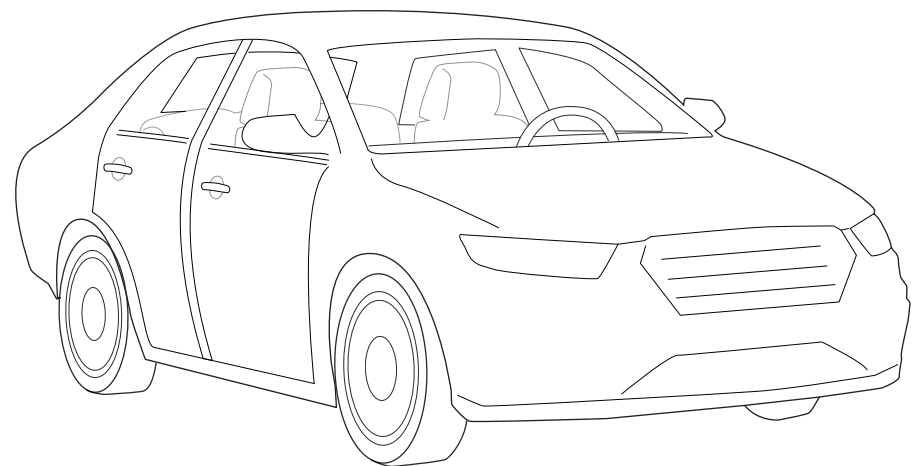
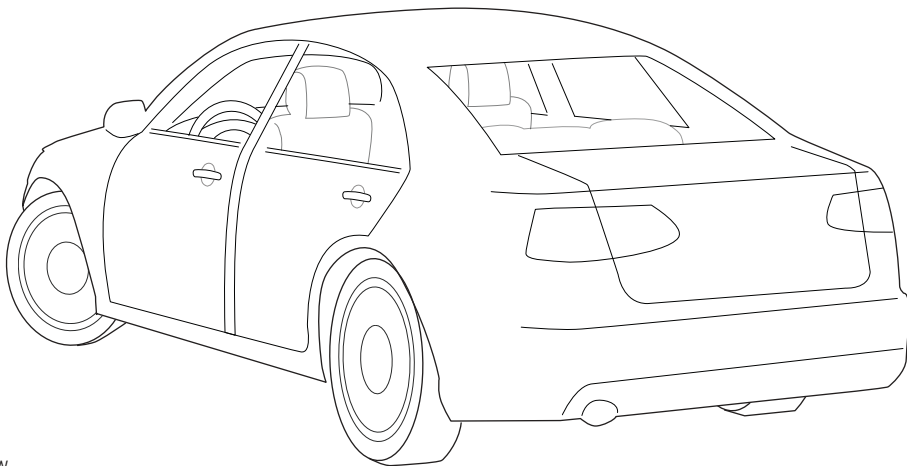
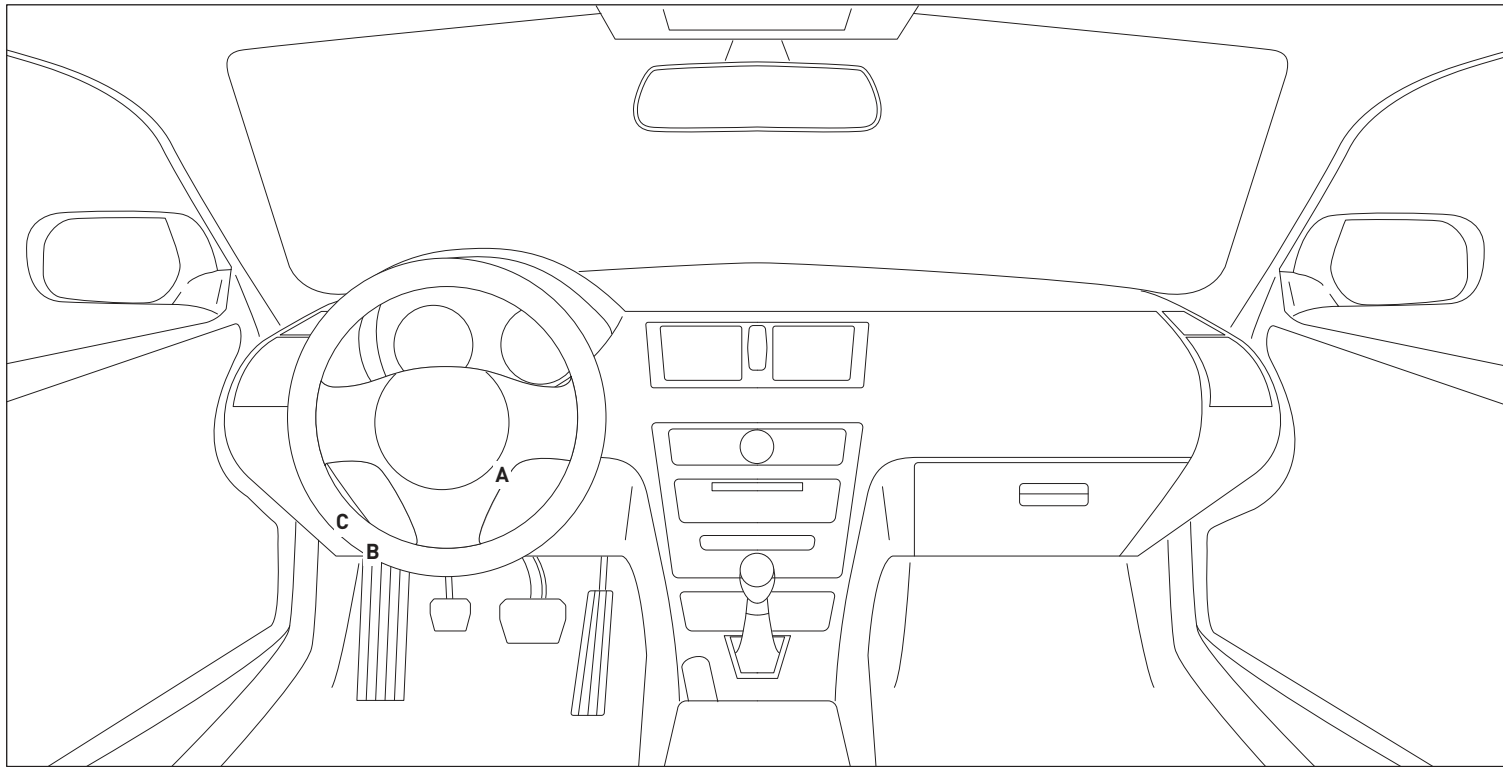

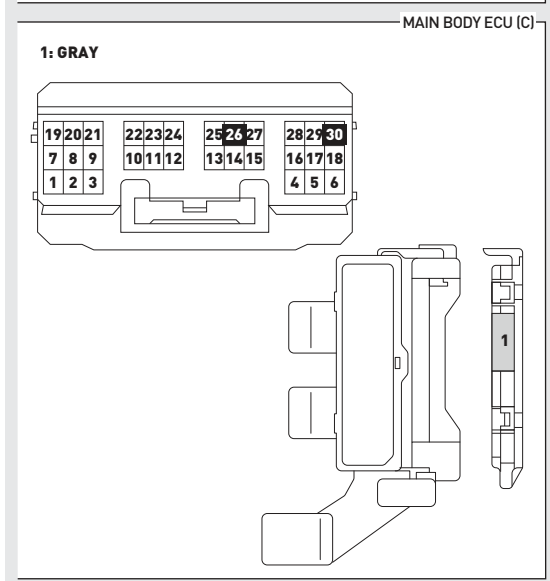
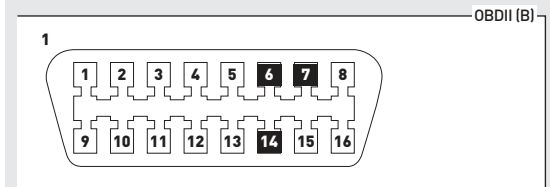
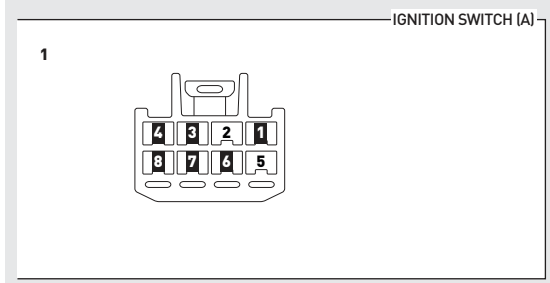
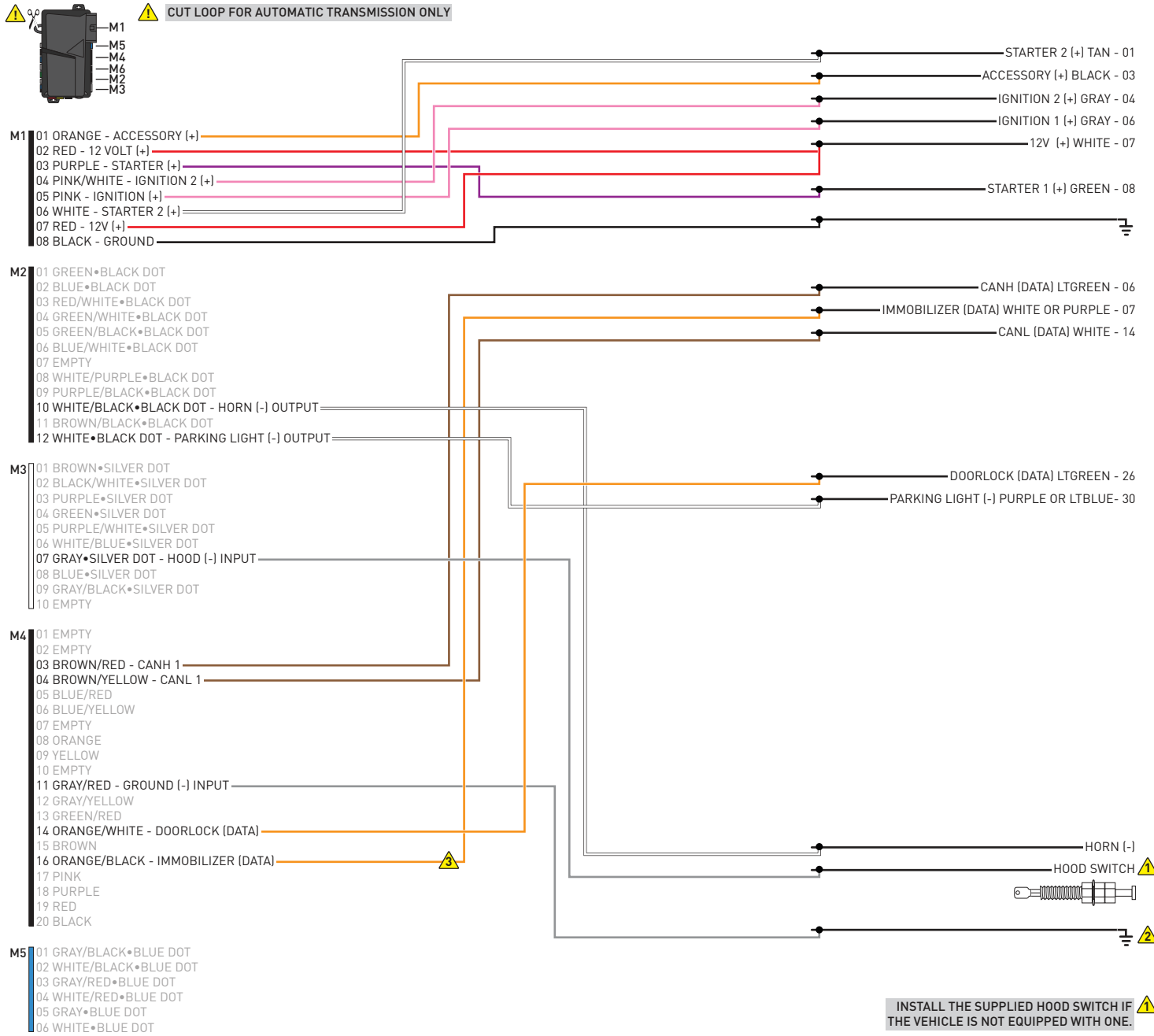



⚠ INSTALL THE SUPPLIED HOOD SWITCH IF THE VEHICLE IS NOT EQUIPPED WITH ONE.

⚠ WITHOUT OEM HOOD STATUS ONLY

⚠ CONNECT ORANGE/BLACK WIRE TO GROUND IF VEHICLE IS NOT EQUIPPED WITH IMMOBILIZER

01  Use the BLACK key only. DO NOT use the GRAY valet key.

02  Turn key to ON position.

03  Wait, LED 1 will turn solid GREEN for 2 seconds.

04  Turn key to OFF position.

05  START vehicle for 15 seconds.

06  Press and hold the brake pedal.

07  Press and release the module's programming button.

08  Release the brake pedal.

09  Wait, LED 2 will flash GREEN.

10  Module Programming Procedure completed.

>>



All vehicle doors must be closed and locked prior to remote start sequence.

01



Press unlock on OEM or aftermarket remote or request switch.

02



DO NOT PRESS BRAKE PEDAL. Set ignition to ON position. Wait 2 seconds for key validation.

03



Press and release BRAKE pedal.

04



Take over procedure completed.

>>



Failure to follow procedure will result in vehicle engine shutdown.

CHECKLIST - WITH AFTERMARKET KEYFOB

1	WARNING: Vehicle engine will start many times. Test in a well ventilated area.
2	Close all vehicle doors, hood and trunk.
3	Press the LOCK button once [1x] on the aftermarket keyfob.
	Question 1: Do the doors lock?
<input type="checkbox"/>	YES: Go to next step.
<input type="checkbox"/>	NO: Verify the remote programming, the RF connections and the wired door lock/unlock connections as illustrated in the wiring diagram, if applicable. Repeat the test and call technical support, if the problem persists.
4	Press the UNLOCK button once [1x] on the aftermarket keyfob.
	Question 2: Do the doors unlock?
<input type="checkbox"/>	YES: Go to next step.
<input type="checkbox"/>	NO: Verify the remote programming, the RF connections and the wired door lock/unlock connections as illustrated in the wiring diagram, if applicable. Repeat the test and call technical support, if the problem persists.
5	Press the TRUNK release button once [1x] on the aftermarket keyfob if supported.
	Question 3: Does the trunk or hatch open/unlock?
<input type="checkbox"/>	YES: Close trunk or hatch and go to next step.
<input type="checkbox"/>	NO: Verify the remote programming, the RF connections and the wired trunk/hatch connections as illustrated in the wiring diagram, if applicable. Repeat the test and call technical support, if the problem persists.
6	Press the AUX 1 button once [1x] on the aftermarket keyfob if supported.
	Question 4: Does the driver side sliding door open?
<input type="checkbox"/>	YES: Press the AUX 1 button once [1x] to close the driver sliding door and go to next step.
<input type="checkbox"/>	NO: Verify the remote programming and the RF connections. Repeat the test and call technical support, if the problem persists.
7	Press the AUX 2 button once [1x] on the aftermarket keyfob if supported.
	Question 5: Does the passenger side sliding door open?
<input type="checkbox"/>	YES: Press the AUX 2 button once [1x] to close the passenger sliding door and go to next step.
<input type="checkbox"/>	NO: Verify the remote programming and the RF connections. Repeat the test and call technical support, if the problem persists.
8	Press the START/STOP button once [1x] on the aftermarket keyfob to remote start vehicle.
	Question 6: Does the vehicle remote start?
<input type="checkbox"/>	YES: Go to next step.
<input type="checkbox"/>	NO: Verify the remote programming, the RF connections and check the remote start error codes. Repeat the test and call technical support, if the problem persists.

9	Press the START/STOP button once [1x] on the aftermarket keyfob to shut down vehicle.
	Question 7: Does the vehicle shut down?
<input type="checkbox"/>	YES: Go to next step.
<input type="checkbox"/>	NO: Repeat step. If problem persists, press the brake pedal once [1x] to shut down the vehicle and call technical support.
10	RAP and auto light shutdown test
	Question 8: Did the radio, interior controls and headlights turn off within 60 seconds after remote start shutdown?
<input type="checkbox"/>	YES: Go to next step.
<input type="checkbox"/>	NO: Verify the RAP SHUTDOWN connections as illustrated in the wiring diagram. Repeat the test and call technical support if the problem persists.
11	Open hood.
12	If not already installed, affix the mandatory orange warning sticker under the hood and proceed to next step.
13	Press the START/STOP button once [1x] on the aftermarket keyfob to remote start vehicle.
	Question 9: Does the vehicle remote start?
<input type="checkbox"/>	YES: The vehicle is not equipped with a factory hood pin. Install a mandatory aftermarket hood switch, then repeat the test.
<input type="checkbox"/>	NO: Go to next step.
14	Close hood.
15	Enter vehicle and close the doors.
16	Press the START/STOP button once [1x] on the aftermarket keyfob to remote start vehicle.
17	Wait for the vehicle to start.
18	Press brake pedal.
	Question 10: Does the vehicle shut down?
<input type="checkbox"/>	YES: Go to next step.
<input type="checkbox"/>	NO: The module does NOT detect the brake pedal signal. Press the START/STOP button once [1x] on the aftermarket keyfob to shut down vehicle, check connection as illustrated in the wiring diagram, if applicable, and call technical support.
19	Exit vehicle.
20	Installation checklist completed.

CHECKLIST - WITH OEM KEYFOB	
1	WARNING: Vehicle engine will start many times. Test in a well ventilated area.
2	Close all vehicle doors, hood and trunk.
3	Press LOCK button three times [3x] rapidly on the OEM keyfob to remote start vehicle.
	Question 1: Does the vehicle remote start?
<input type="checkbox"/>	YES: Go to next step.
<input type="checkbox"/>	NO: The module doesn't detect OEM remote lock button from the vehicle communication network. Check all connections, repeat the test and call technical support, if the problem persists.
4	Press LOCK button three times [3x] rapidly on the OEM keyfob to shut down vehicle.
	Question 2: Does the vehicle shut down?
<input type="checkbox"/>	YES: Go to next step.
<input type="checkbox"/>	NO: Repeat step. If the problem persists, press on the brake pedal once [1x] to shut down the vehicle and call technical support.
5	RAP Shutdown test
	Question 3: Did the radio, interior controls, and headlights turn off within 60 seconds after remote start shutdown?
<input type="checkbox"/>	YES: Go to next step.
<input type="checkbox"/>	NO: Verify the RAP SHUTDOWN connections as illustrated in the wiring diagram. Repeat the test and call technical support, if the problem persists.
6	Open hood.
7	If not already installed, affix the mandatory orange warning sticker under the hood and proceed to next step.
8	Press LOCK button three times [3x] rapidly on the OEM keyfob to remote start vehicle.
	Question 4: Does the vehicle remote start?
<input type="checkbox"/>	YES: The vehicle is not equipped with a factory hood pin. Install a mandatory aftermarket hood switch, then repeat the test.
<input type="checkbox"/>	NO: Go to next step.
9	Close hood.
10	Enter vehicle and close the doors.
11	Press LOCK button three times [3x] rapidly on the OEM keyfob to remote start vehicle.
12	Wait for the vehicle to start.
13	Press brake pedal.
	Question 5: Does the vehicle shut down?
<input type="checkbox"/>	YES: Go to next step.
<input type="checkbox"/>	NO: The module does NOT detect the brake pedal signal. Press LOCK button three times [3x] rapidly on the OEM keyfob to shut down, check the brake connection as illustrated in the wiring diagram, if applicable, and call technical support.
14	Exit vehicle.
15	Installation checklist completed.

COMPUSTAR®

INSTALL GUIDE

2011-2015 SCION XB 80-BIT STD KEY AT

DOCUMENT NUMBER

REVISION DATE

20180926

FIRMWARE

COM-RSA-TL5-[RS1B-DC3]

HARDWARE

RS1B-DC3

ACCESSORIES

ATTENTION: TO COMPLETE THIS INSTALLATION SOME ACCESSORIES MAY BE REQUIRED. VISIT OUR WEBSITE TO SEE ALL THE REQUIRED ACCESSORIES FOR YOUR VEHICLE.

TERMS OF USE

Automotive Data Solutions Inc. ("ADS") products are strictly intended for installation by Certified Technicians who are employed by a registered business specialized in the installation of automotive aftermarket electronics products. Prior to beginning installation of an ADS product in a vehicle, it is the Certified Technician's responsibility to review the most current Product Guide, Install Guide and vehicle-specific notes available in Weblink®. ADS is not responsible for any damages whatsoever, including but not limited to any consequential damages, incidental damages, damages for loss of time, loss of earnings, loss of profit, commercial loss, loss of economic opportunity and the like that may or may not have resulted from the use, misuse, improper installation or operation of its products. ADS reserves itself the right to suspend any Weblink® account without notice and decline to offer technical support to non-Certified Technicians, non-compliant Certified Technicians or end users.



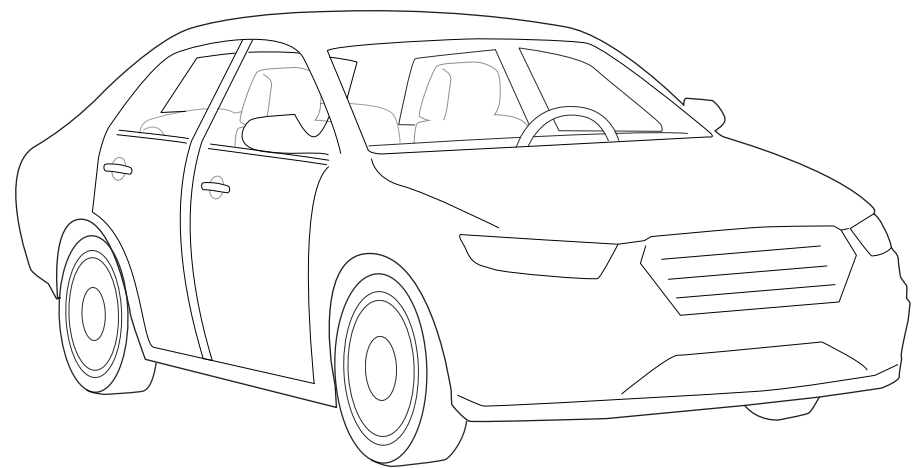
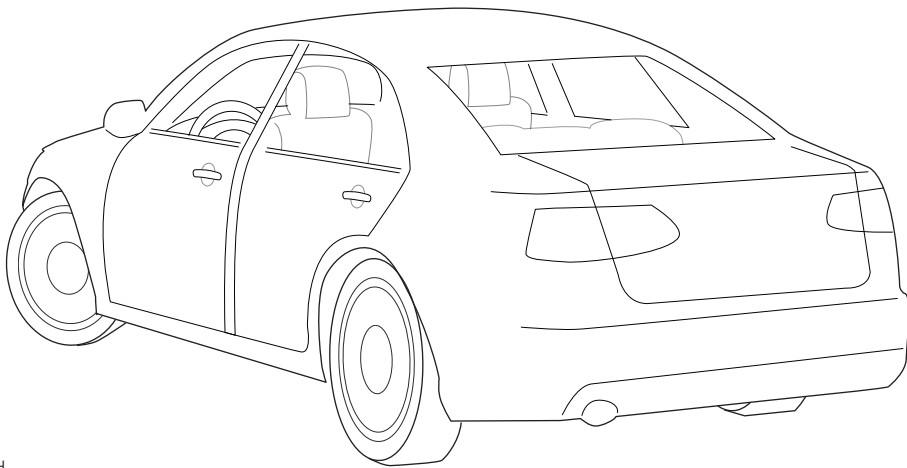
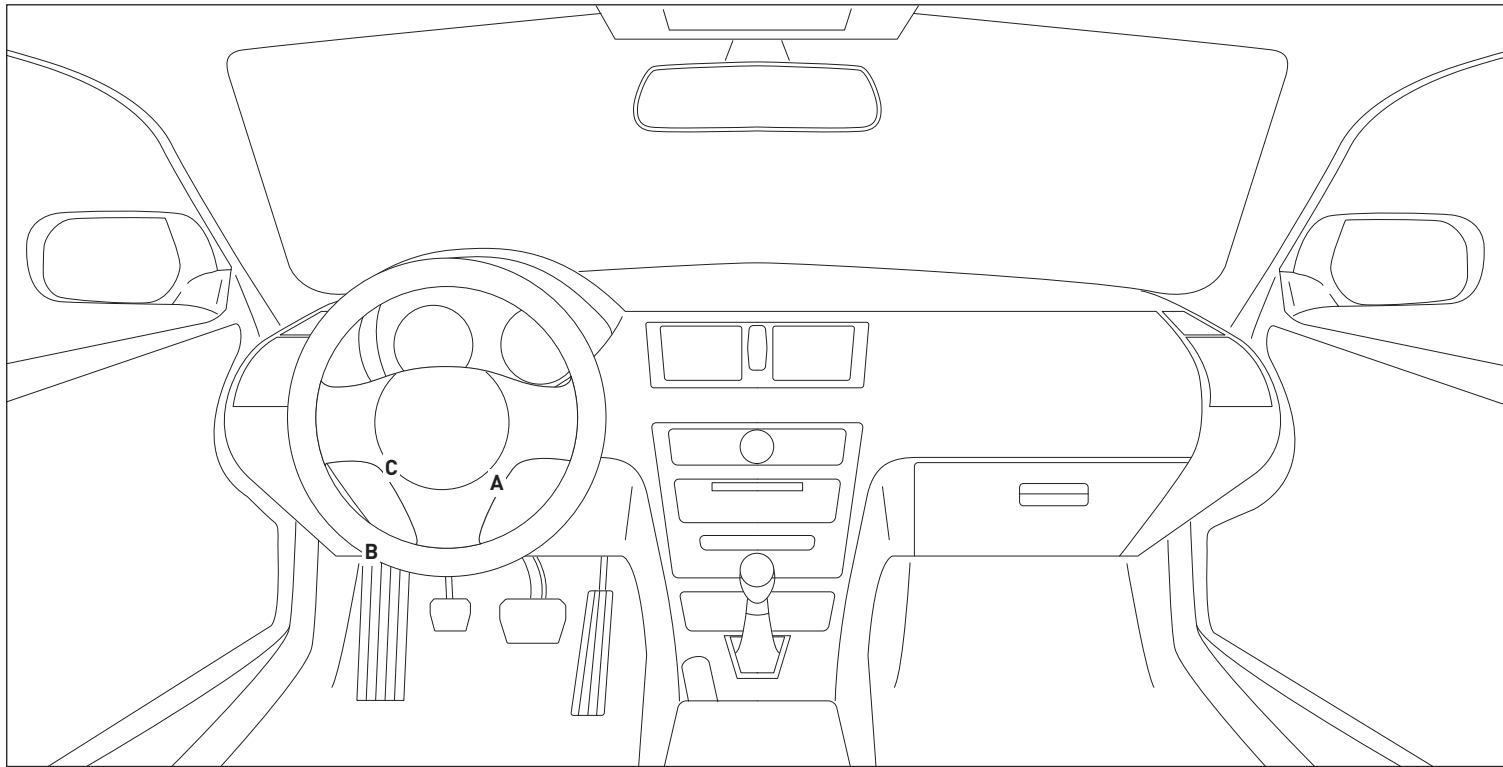

- CUT LOOP FOR AUTOMATIC TRANSMISSION ONLY
- SOME PARTS OF THE T-HARNESS (MS4-C, MS3-B, VS3/VS4 AND JS8) ARE NOT USED IN THIS INSTALL DO NOT CONNECT THEM.
- JS7 IS NOT USED IF THE VEHICLE IS EQUIPPED WITH AN IMMOBILIZER

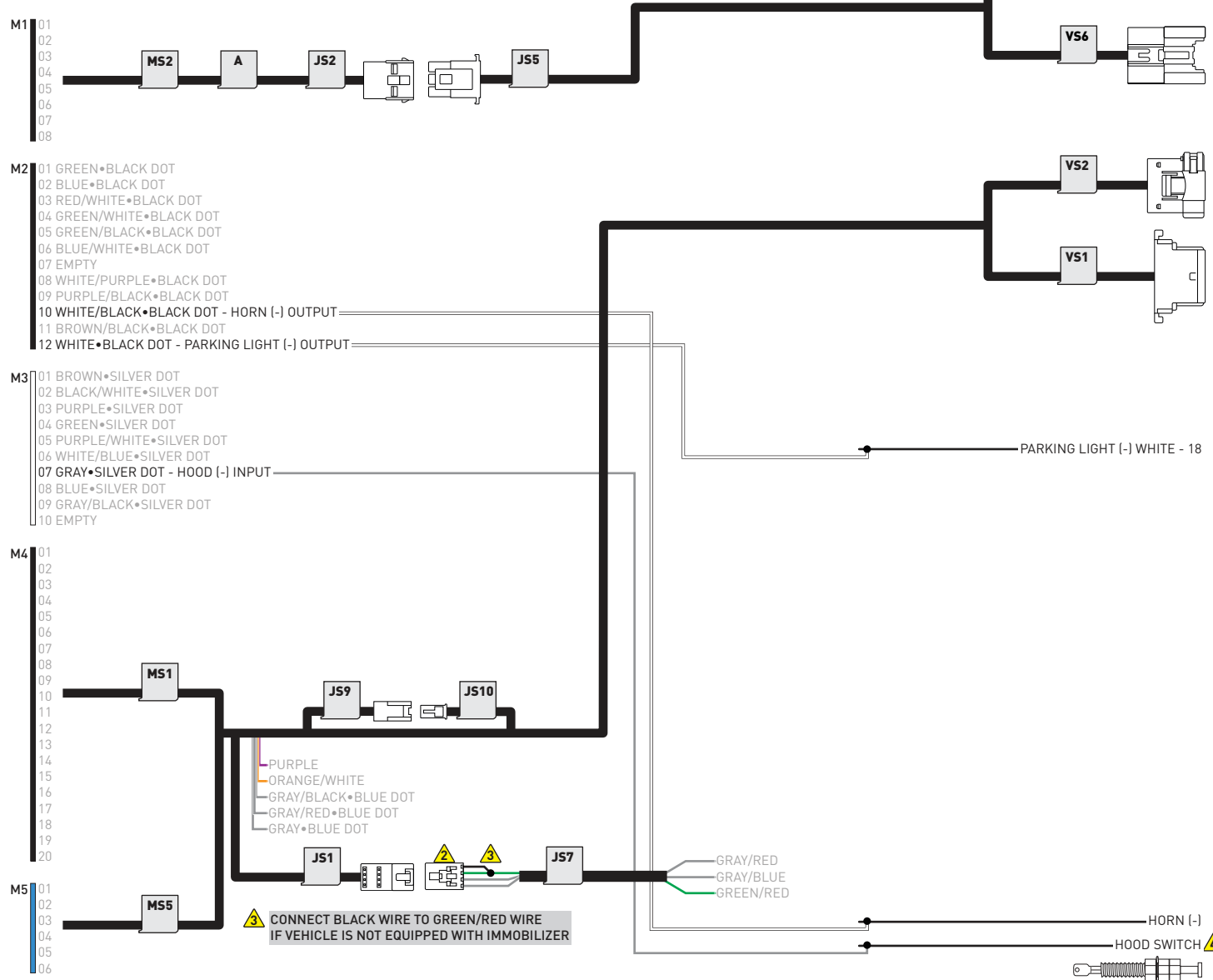

CONNECT BLACK WIRE TO GREEN/RED WIRE IF VEHICLE IS NOT EQUIPPED WITH IMMOBILIZER

IF NOT EQUIPPED WITH AN OEM HOOD PIN:
- INSTALL THE SUPPLIED HOOD SWITCH.
 - CHANGE REMOTE STARTER INPUT CONFIGURATION (MENU #7) "4- HOOD INPUT SOURCE" TO "1- ANALOG".

IGNITION SWITCH (A)

1: IGNITION CONNECTOR

1: IGNITION HARNESS

OBDII (B)

1: OBDII CONNECTOR

1: OBDII HOLDER

PARKING LIGHT SWITCH (C)

1

10	9	8	7	6	5	4	3	2	1
20	19	18	17	16	15	14	13	12	11

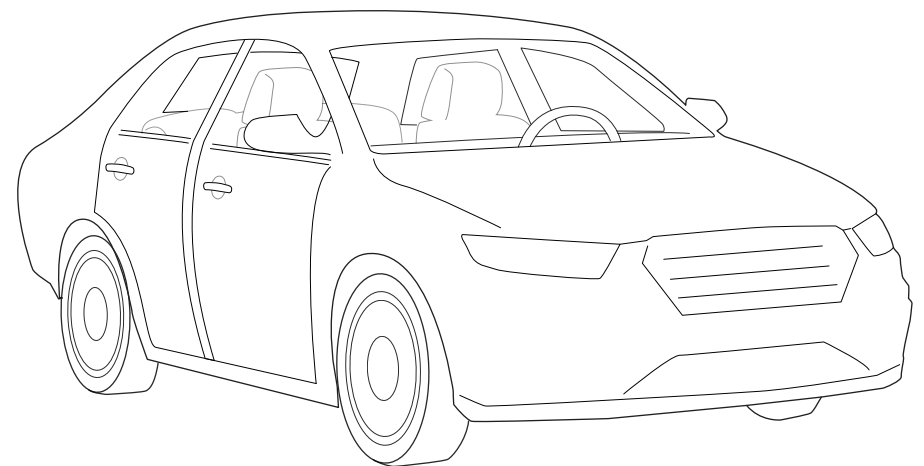
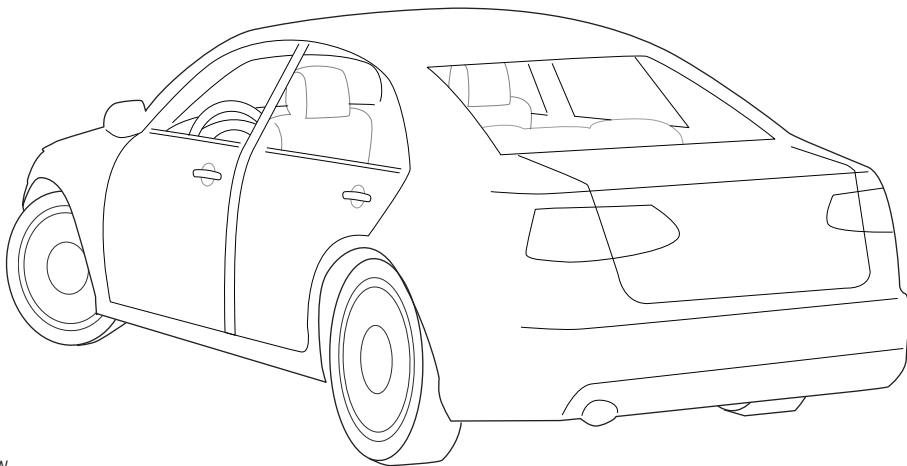
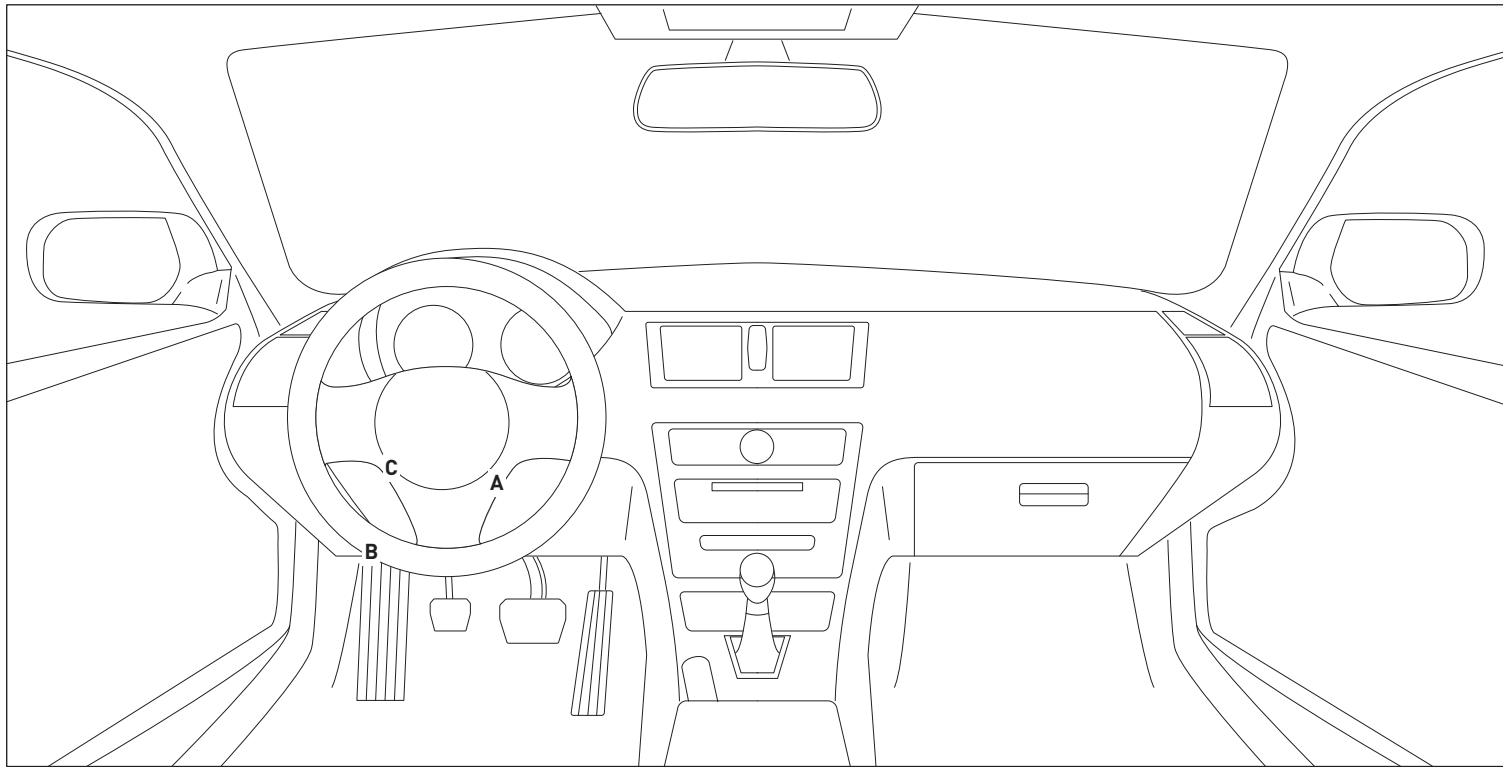

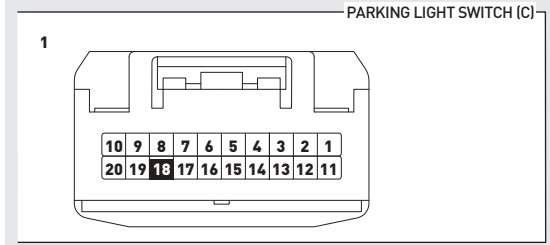
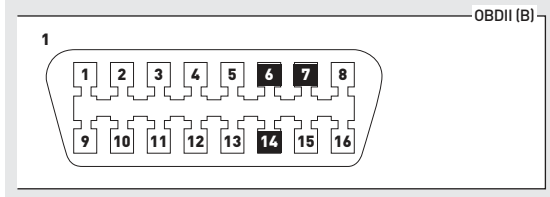
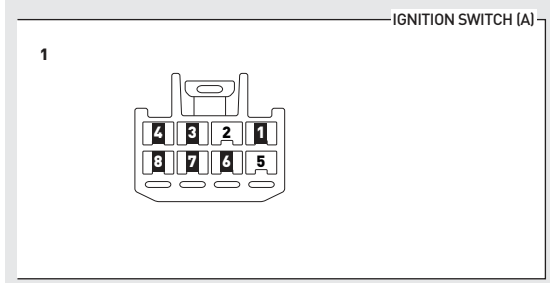
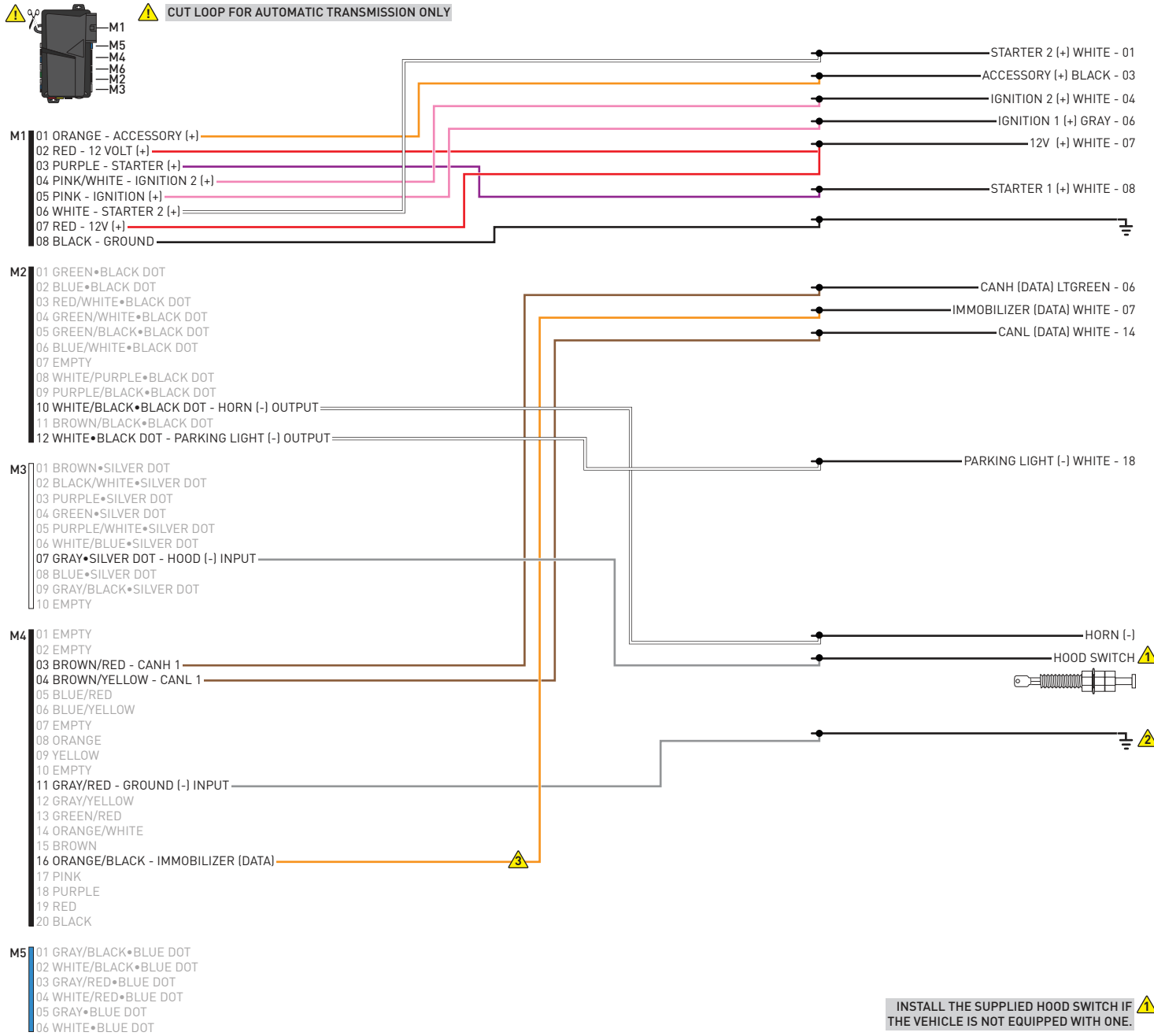

1 INSTALL THE SUPPLIED HOOD SWITCH IF THE VEHICLE IS NOT EQUIPPED WITH ONE.

2 WITHOUT OEM HOOD STATUS ONLY

3 CONNECT ORANGE/BLACK WIRE TO GROUND IF VEHICLE IS NOT EQUIPPED WITH IMMOBILIZER

01  Use the BLACK key only. DO NOT use the GRAY valet key.

02  Turn key to ON position.

03  Wait, LED 1 will turn solid GREEN for 2 seconds.

04  Turn key to OFF position.

05  START vehicle for 15 seconds.

06  Press and hold the brake pedal.

07  Press and release the module's programming button.

08  Release the brake pedal.

09  Wait, LED 2 will flash GREEN.

10  Module Programming Procedure completed.

>>



All vehicle doors must be closed and locked prior to remote start sequence.

01



Press unlock on OEM or aftermarket remote or request switch.

02



DO NOT PRESS BRAKE PEDAL. Set ignition to ON position. Wait 2 seconds for key validation.

03



Press and release BRAKE pedal.

04



Take over procedure completed.

>>



Failure to follow procedure will result in vehicle engine shutdown.

CHECKLIST - WITH AFTERMARKET KEYFOB

1	WARNING: Vehicle engine will start many times. Test in a well ventilated area.	9	Press the START/STOP button once [1x] on the aftermarket keyfob to shut down vehicle.
2	Close all vehicle doors, hood and trunk.		Question 7: Does the vehicle shut down?
3	Press the LOCK button once [1x] on the aftermarket keyfob.	<input type="checkbox"/>	YES: Go to next step.
	Question 1: Do the doors lock?	<input type="checkbox"/>	NO: Repeat step. If problem persists, press the brake pedal once [1x] to shut down the vehicle and call technical support.
<input type="checkbox"/>	YES: Go to next step.	10	RAP and auto light shutdown test
<input type="checkbox"/>	NO: Verify the remote programming, the RF connections and the wired door lock/unlock connections as illustrated in the wiring diagram, if applicable. Repeat the test and call technical support, if the problem persists.		Question 8: Did the radio, interior controls and headlights turn off within 60 seconds after remote start shutdown?
4	Press the UNLOCK button once [1x] on the aftermarket keyfob.	<input type="checkbox"/>	YES: Go to next step.
	Question 2: Do the doors unlock?	<input type="checkbox"/>	NO: Verify the RAP SHUTDOWN connections as illustrated in the wiring diagram. Repeat the test and call technical support if the problem persists.
<input type="checkbox"/>	YES: Go to next step.	11	Open hood.
<input type="checkbox"/>	NO: Verify the remote programming, the RF connections and the wired door lock/unlock connections as illustrated in the wiring diagram, if applicable. Repeat the test and call technical support, if the problem persists.	12	If not already installed, affix the mandatory orange warning sticker under the hood and proceed to next step.
5	Press the TRUNK release button once [1x] on the aftermarket keyfob if supported.	13	Press the START/STOP button once [1x] on the aftermarket keyfob to remote start vehicle.
	Question 3: Does the trunk or hatch open/unlock?		Question 9: Does the vehicle remote start?
<input type="checkbox"/>	YES: Close trunk or hatch and go to next step.	<input type="checkbox"/>	YES: The vehicle is not equipped with a factory hood pin. Install a mandatory aftermarket hood switch, then repeat the test.
<input type="checkbox"/>	NO: Verify the remote programming, the RF connections and the wired trunk/hatch connections as illustrated in the wiring diagram, if applicable. Repeat the test and call technical support, if the problem persists.	<input type="checkbox"/>	NO: Go to next step.
6	Press the AUX 1 button once [1x] on the aftermarket keyfob if supported.	14	Close hood.
	Question 4: Does the driver side sliding door open?	15	Enter vehicle and close the doors.
<input type="checkbox"/>	YES: Press the AUX 1 button once [1x] to close the driver sliding door and go to next step.	16	Press the START/STOP button once [1x] on the aftermarket keyfob to remote start vehicle.
<input type="checkbox"/>	NO: Verify the remote programming and the RF connections. Repeat the test and call technical support, if the problem persists.	17	Wait for the vehicle to start.
7	Press the AUX 2 button once [1x] on the aftermarket keyfob if supported.	18	Press brake pedal.
	Question 5: Does the passenger side sliding door open?		Question 10: Does the vehicle shut down?
<input type="checkbox"/>	YES: Press the AUX 2 button once [1x] to close the passenger sliding door and go to next step.	<input type="checkbox"/>	YES: Go to next step.
<input type="checkbox"/>	NO: Verify the remote programming and the RF connections. Repeat the test and call technical support, if the problem persists.	<input type="checkbox"/>	NO: The module does NOT detect the brake pedal signal. Press the START/STOP button once [1x] on the aftermarket keyfob to shut down vehicle, check connection as illustrated in the wiring diagram, if applicable, and call technical support.
8	Press the START/STOP button once [1x] on the aftermarket keyfob to remote start vehicle.	19	Exit vehicle.
	Question 6: Does the vehicle remote start?	20	Installation checklist completed.
<input type="checkbox"/>	YES: Go to next step.		
<input type="checkbox"/>	NO: Verify the remote programming, the RF connections and check the remote start error codes. Repeat the test and call technical support, if the problem persists.		

CHECKLIST - WITH OEM KEYFOB	
1	WARNING: Vehicle engine will start many times. Test in a well ventilated area.
2	Close all vehicle doors, hood and trunk.
3	Press LOCK button three times [3x] rapidly on the OEM keyfob to remote start vehicle.
	Question 1: Does the vehicle remote start?
<input type="checkbox"/>	YES: Go to next step.
<input type="checkbox"/>	NO: The module doesn't detect OEM remote lock button from the vehicle communication network. Check all connections, repeat the test and call technical support, if the problem persists.
4	Press LOCK button three times [3x] rapidly on the OEM keyfob to shut down vehicle.
	Question 2: Does the vehicle shut down?
<input type="checkbox"/>	YES: Go to next step.
<input type="checkbox"/>	NO: Repeat step. If the problem persists, press on the brake pedal once [1x] to shut down the vehicle and call technical support.
5	RAP Shutdown test
	Question 3: Did the radio, interior controls, and headlights turn off within 60 seconds after remote start shutdown?
<input type="checkbox"/>	YES: Go to next step.
<input type="checkbox"/>	NO: Verify the RAP SHUTDOWN connections as illustrated in the wiring diagram. Repeat the test and call technical support, if the problem persists.
6	Open hood.
7	If not already installed, affix the mandatory orange warning sticker under the hood and proceed to next step.
8	Press LOCK button three times [3x] rapidly on the OEM keyfob to remote start vehicle.
	Question 4: Does the vehicle remote start?
<input type="checkbox"/>	YES: The vehicle is not equipped with a factory hood pin. Install a mandatory aftermarket hood switch, then repeat the test.
<input type="checkbox"/>	NO: Go to next step.
9	Close hood.
10	Enter vehicle and close the doors.
11	Press LOCK button three times [3x] rapidly on the OEM keyfob to remote start vehicle.
12	Wait for the vehicle to start.
13	Press brake pedal.
	Question 5: Does the vehicle shut down?
<input type="checkbox"/>	YES: Go to next step.
<input type="checkbox"/>	NO: The module does NOT detect the brake pedal signal. Press LOCK button three times [3x] rapidly on the OEM keyfob to shut down, check the brake connection as illustrated in the wiring diagram, if applicable, and call technical support.
14	Exit vehicle.
15	Installation checklist completed.

COMPUSTAR®

INSTALL GUIDE

2011-2014 SCION XD 80-BIT STD KEY AT



DOCUMENT NUMBER

REVISION DATE

20180926

FIRMWARE

COM-RSA-TL5-[RS1B-DC3]

HARDWARE

RS1B-DC3

ACCESSORIES

ATTENTION: TO COMPLETE THIS INSTALLATION SOME ACCESSORIES MAY BE REQUIRED. VISIT OUR WEBSITE TO SEE ALL THE REQUIRED ACCESSORIES FOR YOUR VEHICLE.

TERMS OF USE

Automotive Data Solutions Inc. ("ADS") products are strictly intended for installation by Certified Technicians who are employed by a registered business specialized in the installation of automotive aftermarket electronics products. Prior to beginning installation of an ADS product in a vehicle, it is the Certified Technician's responsibility to review the most current Product Guide, Install Guide and vehicle-specific notes available in Weblink®. ADS is not responsible for any damages whatsoever, including but not limited to any consequential damages, incidental damages, damages for loss of time, loss of earnings, loss of profit, commercial loss, loss of economic opportunity and the like that may or may not have resulted from the use, misuse, improper installation or operation of its products. ADS reserves itself the right to suspend any Weblink® account without notice and decline to offer technical support to non-Certified Technicians, non-compliant Certified Technicians or end users.

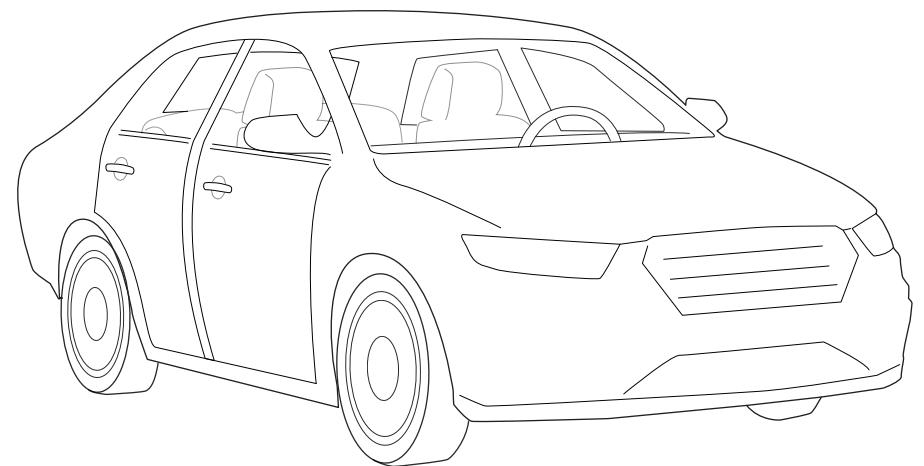
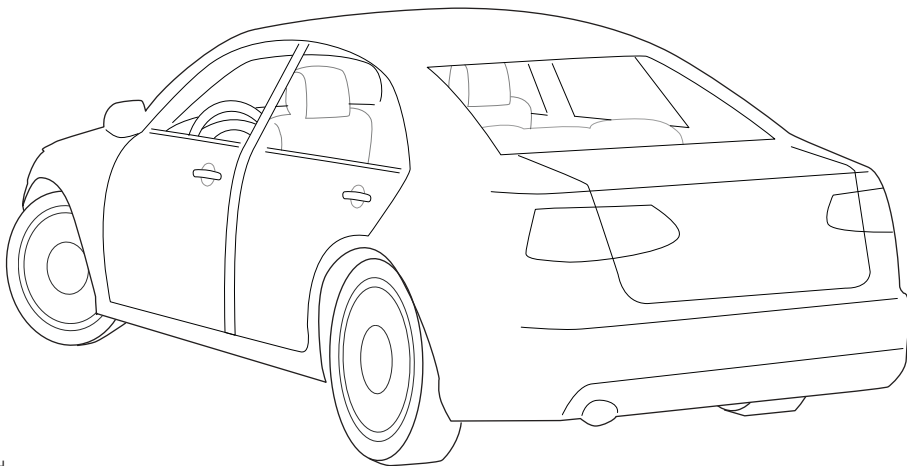
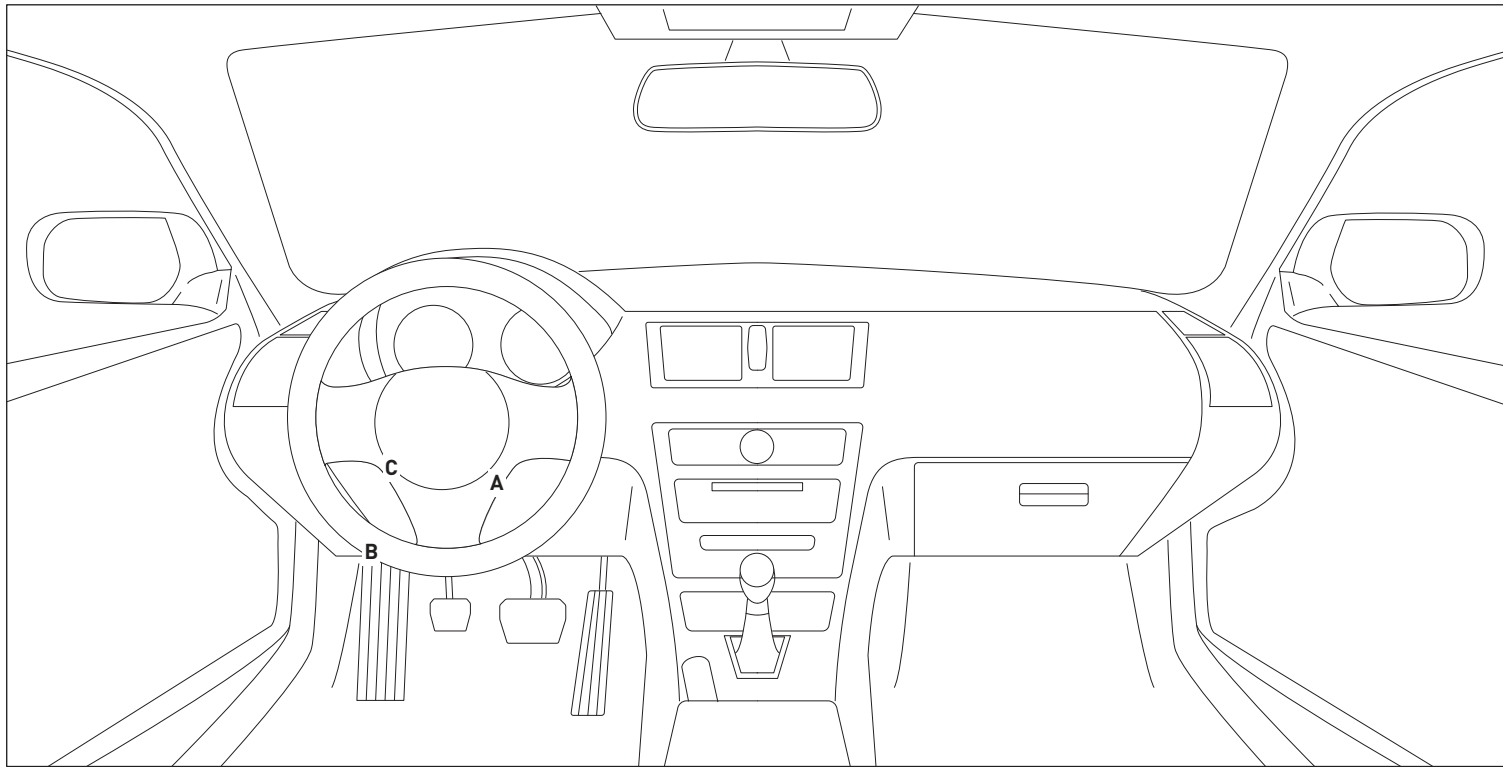

- CUT LOOP FOR AUTOMATIC TRANSMISSION ONLY
- SOME PARTS OF THE T-HARNESS (MS4-C, MS2-A, VS3/VS4 AND JS8) ARE NOT USED IN THIS INSTALL DO NOT CONNECT THEM.
- JS7 IS NOT USED IF THE VEHICLE IS EQUIPPED WITH AN IMMOBILIZER

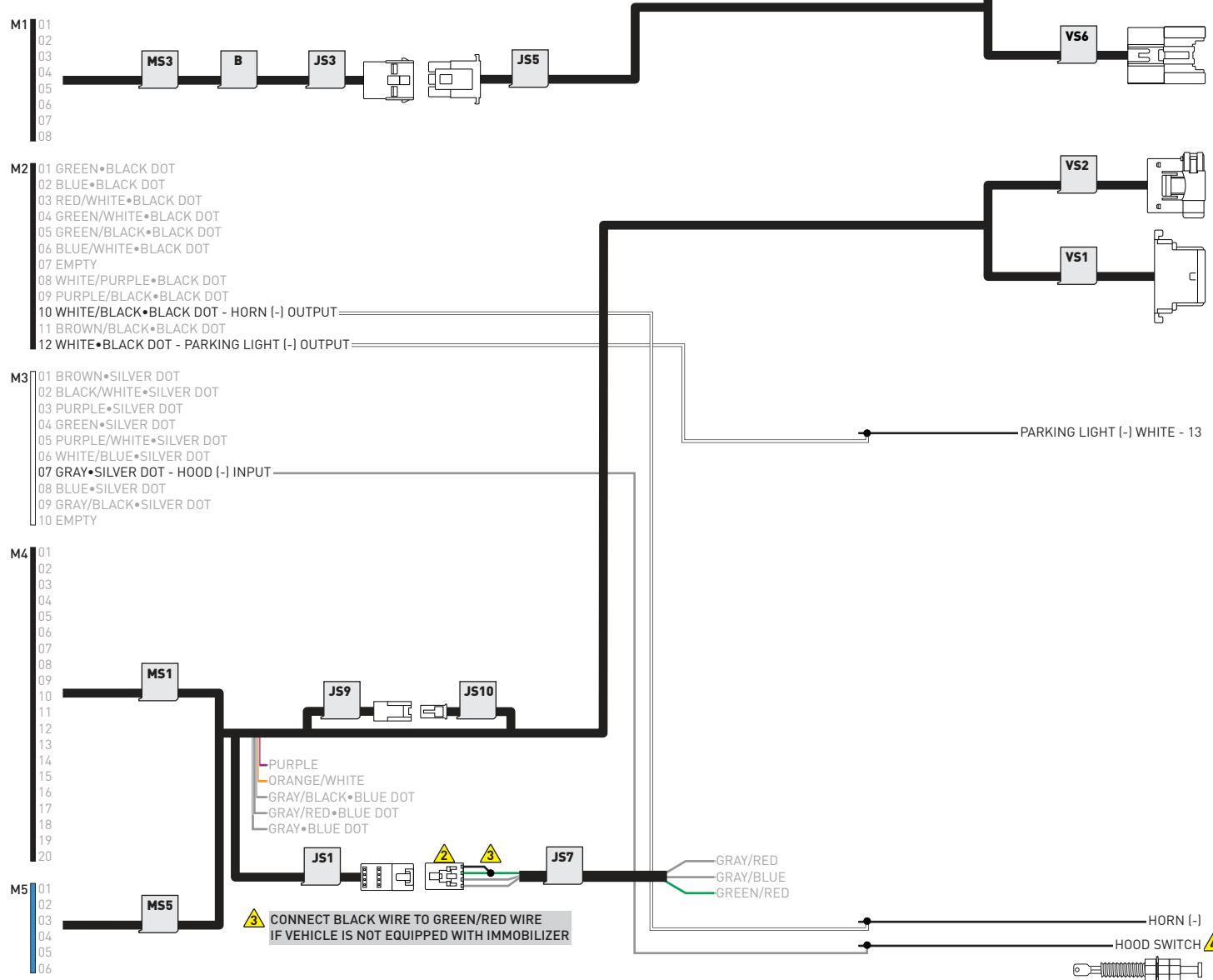

CONNECT BLACK WIRE TO GREEN/RED WIRE IF VEHICLE IS NOT EQUIPPED WITH IMMOBILIZER

IF NOT EQUIPPED WITH AN OEM HOOD PIN: - INSTALL THE SUPPLIED HOOD SWITCH.
- CHANGE REMOTE STARTER INPUT CONFIGURATION (MENU #7) "4- HOOD INPUT SOURCE" TO "1- ANALOG".

IGNITION SWITCH (A)

1: IGNITION CONNECTOR

1: IGNITION HARNESS

OBDII (B)

1: OBDII CONNECTOR

1: OBDII HOLDER

PARKING LIGHT SWITCH (C)

1: WHITE

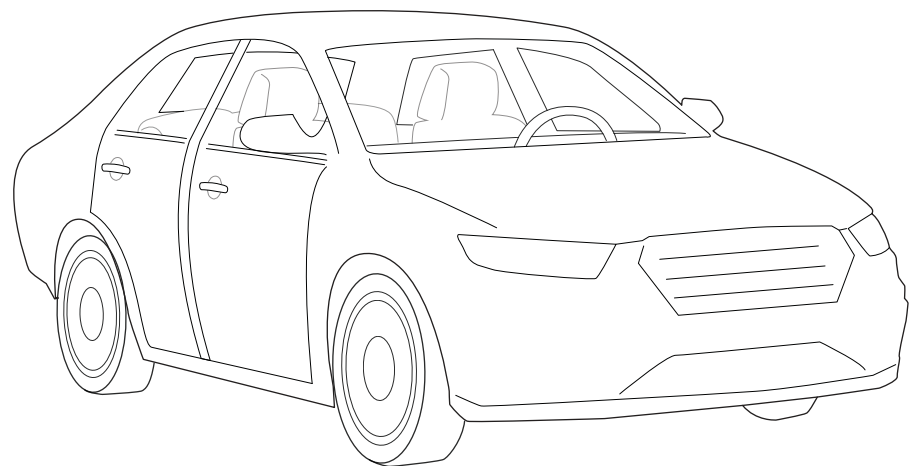
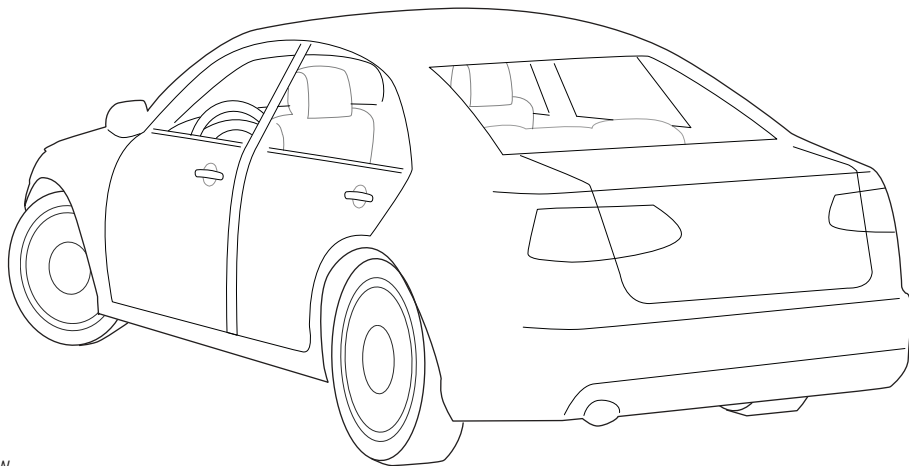
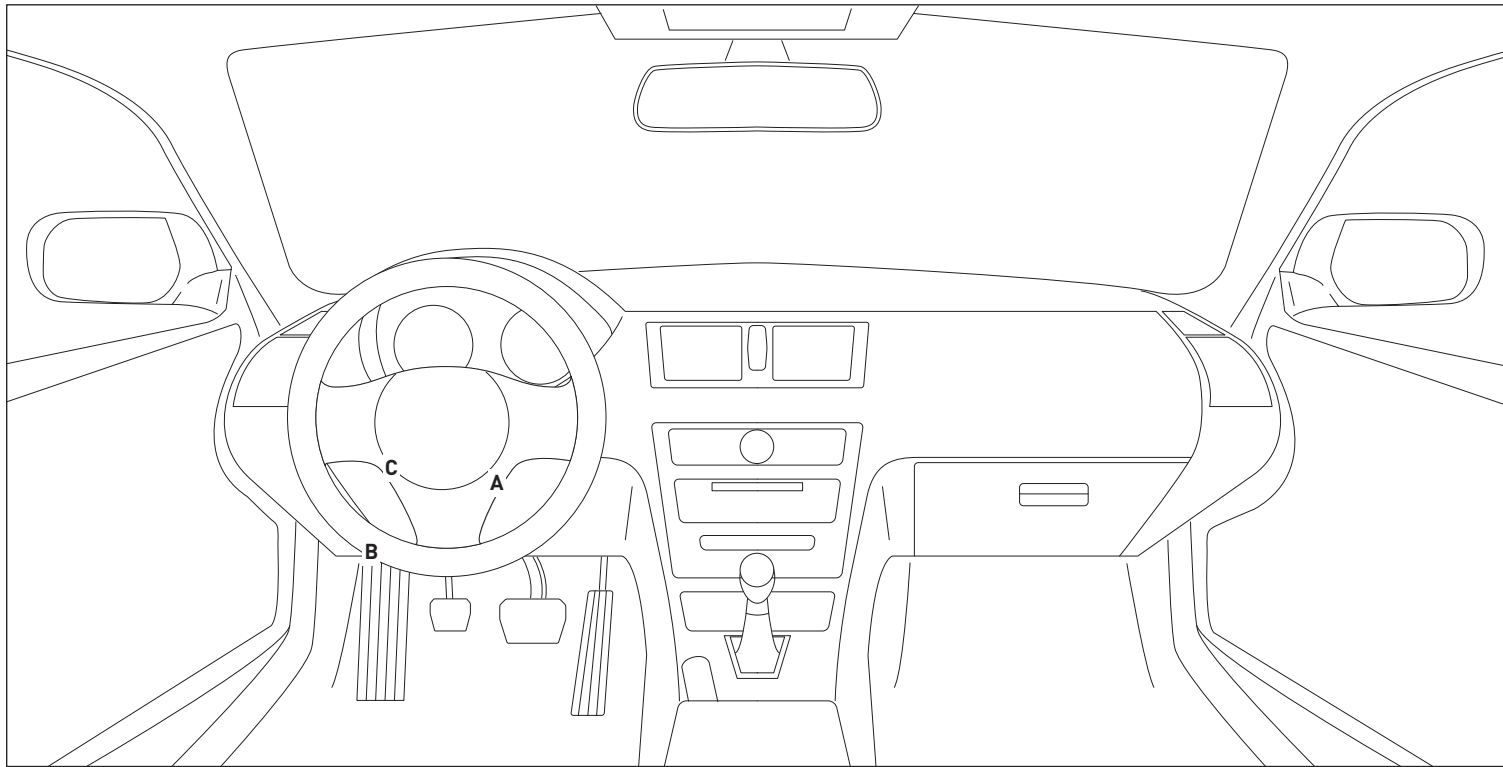

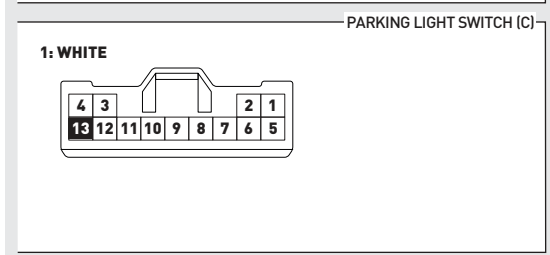
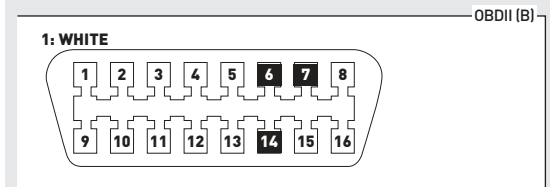
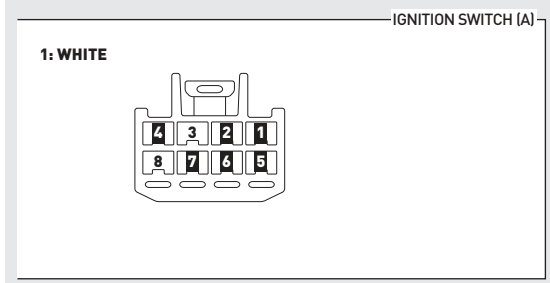
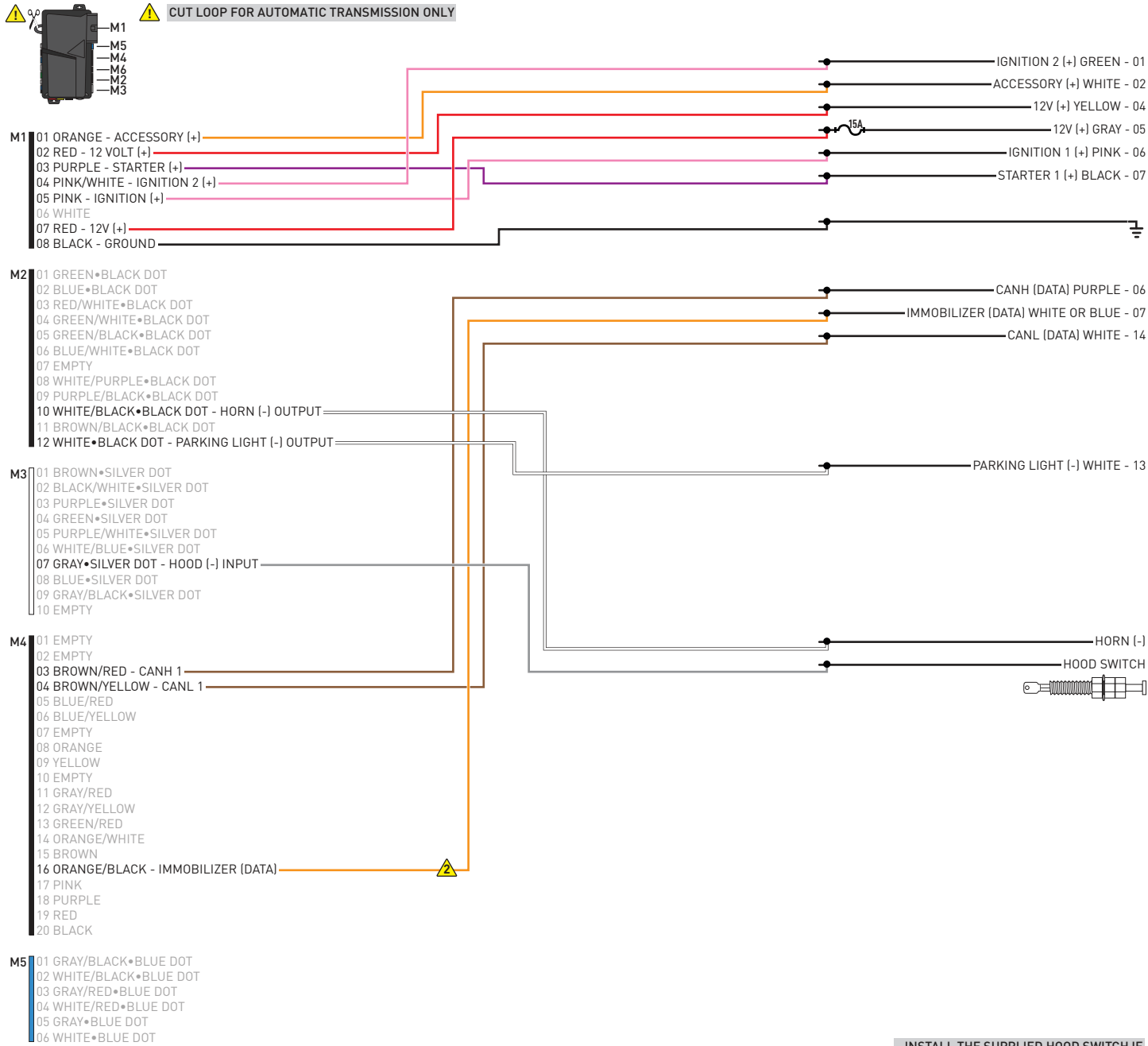

⚠ INSTALL THE SUPPLIED HOOD SWITCH IF THE VEHICLE IS NOT EQUIPPED WITH ONE.

⚠ CONNECT ORANGE/BLACK WIRE TO GROUND IF VEHICLE IS NOT EQUIPPED WITH IMMOBILIZER

01  Use the BLACK key only. DO NOT use the GRAY valet key.

02  Turn key to ON position.

03  Wait, LED 1 will turn solid GREEN for 2 seconds.

04  Turn key to OFF position.

05  START vehicle for 15 seconds.

06  Press and hold the brake pedal.

07  Press and release the module's programming button.

08  Release the brake pedal.

09  Wait, LED 2 will flash GREEN.

10  Module Programming Procedure completed.

>>



All vehicle doors must be closed and locked prior to remote start sequence.

01



Press unlock on OEM or aftermarket remote or request switch.

02



DO NOT PRESS BRAKE PEDAL. Set ignition to ON position. Wait 2 seconds for key validation.

03



Press and release BRAKE pedal.

04



Take over procedure completed.

>>



Failure to follow procedure will result in vehicle engine shutdown.

CHECKLIST - WITH AFTERMARKET KEYFOB

1	WARNING: Vehicle engine will start many times. Test in a well ventilated area.	9	Press the START/STOP button once [1x] on the aftermarket keyfob to shut down vehicle.
2	Close all vehicle doors, hood and trunk.		Question 7: Does the vehicle shut down?
3	Press the LOCK button once [1x] on the aftermarket keyfob.	<input type="checkbox"/>	YES: Go to next step.
	Question 1: Do the doors lock?	<input type="checkbox"/>	NO: Repeat step. If problem persists, press the brake pedal once [1x] to shut down the vehicle and call technical support.
<input type="checkbox"/>	YES: Go to next step.	10	RAP and auto light shutdown test
<input type="checkbox"/>	NO: Verify the remote programming, the RF connections and the wired door lock/unlock connections as illustrated in the wiring diagram, if applicable. Repeat the test and call technical support, if the problem persists.		Question 8: Did the radio, interior controls and headlights turn off within 60 seconds after remote start shutdown?
4	Press the UNLOCK button once [1x] on the aftermarket keyfob.	<input type="checkbox"/>	YES: Go to next step.
	Question 2: Do the doors unlock?	<input type="checkbox"/>	NO: Verify the RAP SHUTDOWN connections as illustrated in the wiring diagram. Repeat the test and call technical support if the problem persists.
<input type="checkbox"/>	YES: Go to next step.	11	Open hood.
<input type="checkbox"/>	NO: Verify the remote programming, the RF connections and the wired door lock/unlock connections as illustrated in the wiring diagram, if applicable. Repeat the test and call technical support, if the problem persists.	12	If not already installed, affix the mandatory orange warning sticker under the hood and proceed to next step.
5	Press the TRUNK release button once [1x] on the aftermarket keyfob if supported.	13	Press the START/STOP button once [1x] on the aftermarket keyfob to remote start vehicle.
	Question 3: Does the trunk or hatch open/unlock?		Question 9: Does the vehicle remote start?
<input type="checkbox"/>	YES: Close trunk or hatch and go to next step.	<input type="checkbox"/>	YES: The vehicle is not equipped with a factory hood pin. Install a mandatory aftermarket hood switch, then repeat the test.
<input type="checkbox"/>	NO: Verify the remote programming, the RF connections and the wired trunk/hatch connections as illustrated in the wiring diagram, if applicable. Repeat the test and call technical support, if the problem persists.	<input type="checkbox"/>	NO: Go to next step.
6	Press the AUX 1 button once [1x] on the aftermarket keyfob if supported.	14	Close hood.
	Question 4: Does the driver side sliding door open?	15	Enter vehicle and close the doors.
<input type="checkbox"/>	YES: Press the AUX 1 button once [1x] to close the driver sliding door and go to next step.	16	Press the START/STOP button once [1x] on the aftermarket keyfob to remote start vehicle.
<input type="checkbox"/>	NO: Verify the remote programming and the RF connections. Repeat the test and call technical support, if the problem persists.	17	Wait for the vehicle to start.
7	Press the AUX 2 button once [1x] on the aftermarket keyfob if supported.	18	Press brake pedal.
	Question 5: Does the passenger side sliding door open?		Question 10: Does the vehicle shut down?
<input type="checkbox"/>	YES: Press the AUX 2 button once [1x] to close the passenger sliding door and go to next step.	<input type="checkbox"/>	YES: Go to next step.
<input type="checkbox"/>	NO: Verify the remote programming and the RF connections. Repeat the test and call technical support, if the problem persists.	<input type="checkbox"/>	NO: The module does NOT detect the brake pedal signal. Press the START/STOP button once [1x] on the aftermarket keyfob to shut down vehicle, check connection as illustrated in the wiring diagram, if applicable, and call technical support.
8	Press the START/STOP button once [1x] on the aftermarket keyfob to remote start vehicle.	19	Exit vehicle.
	Question 6: Does the vehicle remote start?	20	Installation checklist completed.
<input type="checkbox"/>	YES: Go to next step.		
<input type="checkbox"/>	NO: Verify the remote programming, the RF connections and check the remote start error codes. Repeat the test and call technical support, if the problem persists.		

CHECKLIST - WITH OEM KEYFOB	
1	WARNING: Vehicle engine will start many times. Test in a well ventilated area.
2	Close all vehicle doors, hood and trunk.
3	Press LOCK button three times [3x] rapidly on the OEM keyfob to remote start vehicle.
	Question 1: Does the vehicle remote start?
<input type="checkbox"/>	YES: Go to next step.
<input type="checkbox"/>	NO: The module doesn't detect OEM remote lock button from the vehicle communication network. Check all connections, repeat the test and call technical support, if the problem persists.
4	Press LOCK button three times [3x] rapidly on the OEM keyfob to shut down vehicle.
	Question 2: Does the vehicle shut down?
<input type="checkbox"/>	YES: Go to next step.
<input type="checkbox"/>	NO: Repeat step. If the problem persists, press on the brake pedal once [1x] to shut down the vehicle and call technical support.
5	RAP Shutdown test
	Question 3: Did the radio, interior controls, and headlights turn off within 60 seconds after remote start shutdown?
<input type="checkbox"/>	YES: Go to next step.
<input type="checkbox"/>	NO: Verify the RAP SHUTDOWN connections as illustrated in the wiring diagram. Repeat the test and call technical support, if the problem persists.
6	Open hood.
7	If not already installed, affix the mandatory orange warning sticker under the hood and proceed to next step.
8	Press LOCK button three times [3x] rapidly on the OEM keyfob to remote start vehicle.
	Question 4: Does the vehicle remote start?
<input type="checkbox"/>	YES: The vehicle is not equipped with a factory hood pin. Install a mandatory aftermarket hood switch, then repeat the test.
<input type="checkbox"/>	NO: Go to next step.
9	Close hood.
10	Enter vehicle and close the doors.
11	Press LOCK button three times [3x] rapidly on the OEM keyfob to remote start vehicle.
12	Wait for the vehicle to start.
13	Press brake pedal.
	Question 5: Does the vehicle shut down?
<input type="checkbox"/>	YES: Go to next step.
<input type="checkbox"/>	NO: The module does NOT detect the brake pedal signal. Press LOCK button three times [3x] rapidly on the OEM keyfob to shut down, check the brake connection as illustrated in the wiring diagram, if applicable, and call technical support.
14	Exit vehicle.
15	Installation checklist completed.

COMPUSTAR®

INSTALL GUIDE

2010-2017 TOYOTA 4RUNNER 80-BIT STD KEY AT

DOCUMENT NUMBER

REVISION DATE

20180926

FIRMWARE

COM-RSA-TL5-[RS1B-DC3]

HARDWARE

RS1B-DC3

ACCESSORIES

ATTENTION: TO COMPLETE THIS INSTALLATION SOME ACCESSORIES MAY BE REQUIRED.
VISIT OUR WEBSITE TO SEE ALL THE REQUIRED ACCESSORIES FOR YOUR VEHICLE.

TERMS OF USE

Automotive Data Solutions Inc. ("ADS") products are strictly intended for installation by Certified Technicians who are employed by a registered business specialized in the installation of automotive aftermarket electronics products. Prior to beginning installation of an ADS product in a vehicle, it is the Certified Technician's responsibility to review the most current Product Guide, Install Guide and vehicle-specific notes available in Weblink®. ADS is not responsible for any damages whatsoever, including but not limited to any consequential damages, incidental damages, damages for loss of time, loss of earnings, loss of profit, commercial loss, loss of economic opportunity and the like that may or may not have resulted from the use, misuse, improper installation or operation of its products. ADS reserves itself the right to suspend any Weblink® account without notice and decline to offer technical support to non-Certified Technicians, non-compliant Certified Technicians or end users.



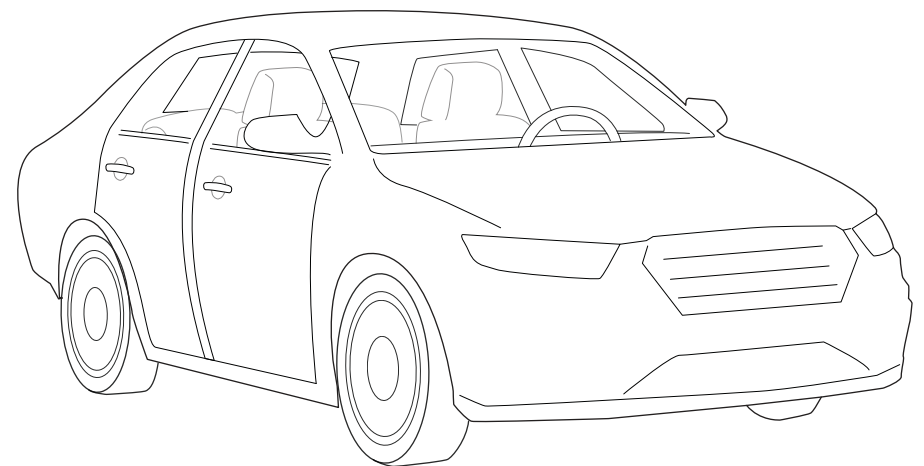
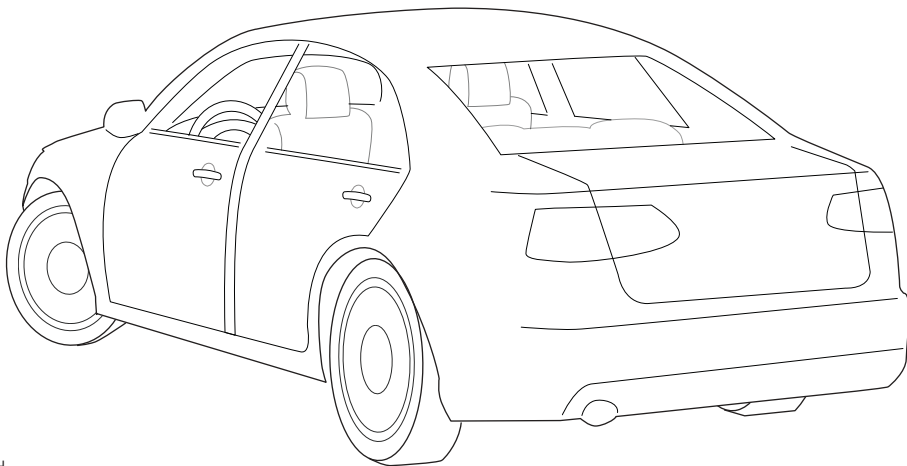
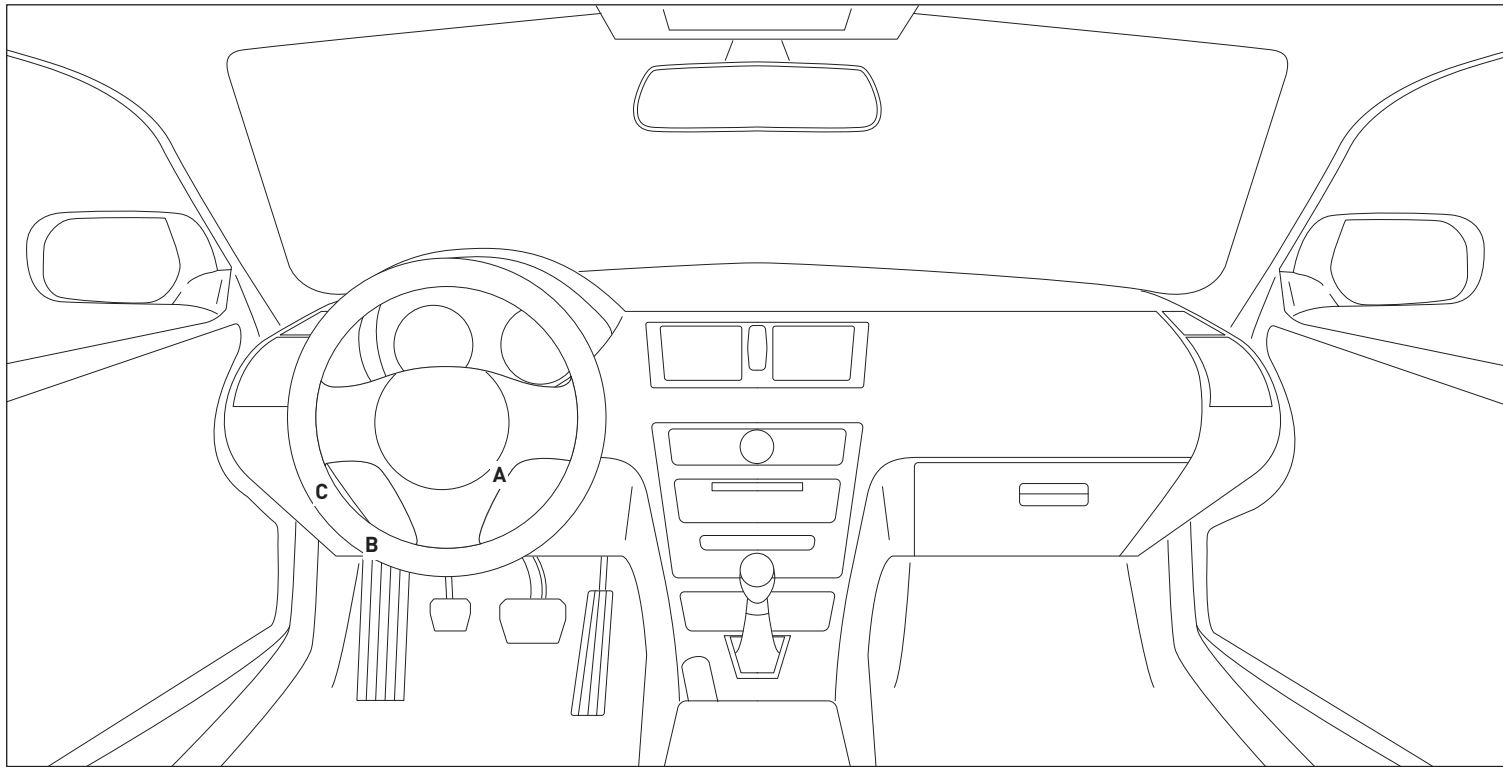

- CUT LOOP FOR AUTOMATIC TRANSMISSION ONLY
- SOME PARTS OF THE T-HARNESS (MS4-C, MS3-B, VS3/VS4 AND JS8) ARE NOT USED IN THIS INSTALL DO NOT CONNECT THEM.
- JS7 IS NOT USED IF THE VEHICLE IS EQUIPPED WITH AN IMMOBILIZER

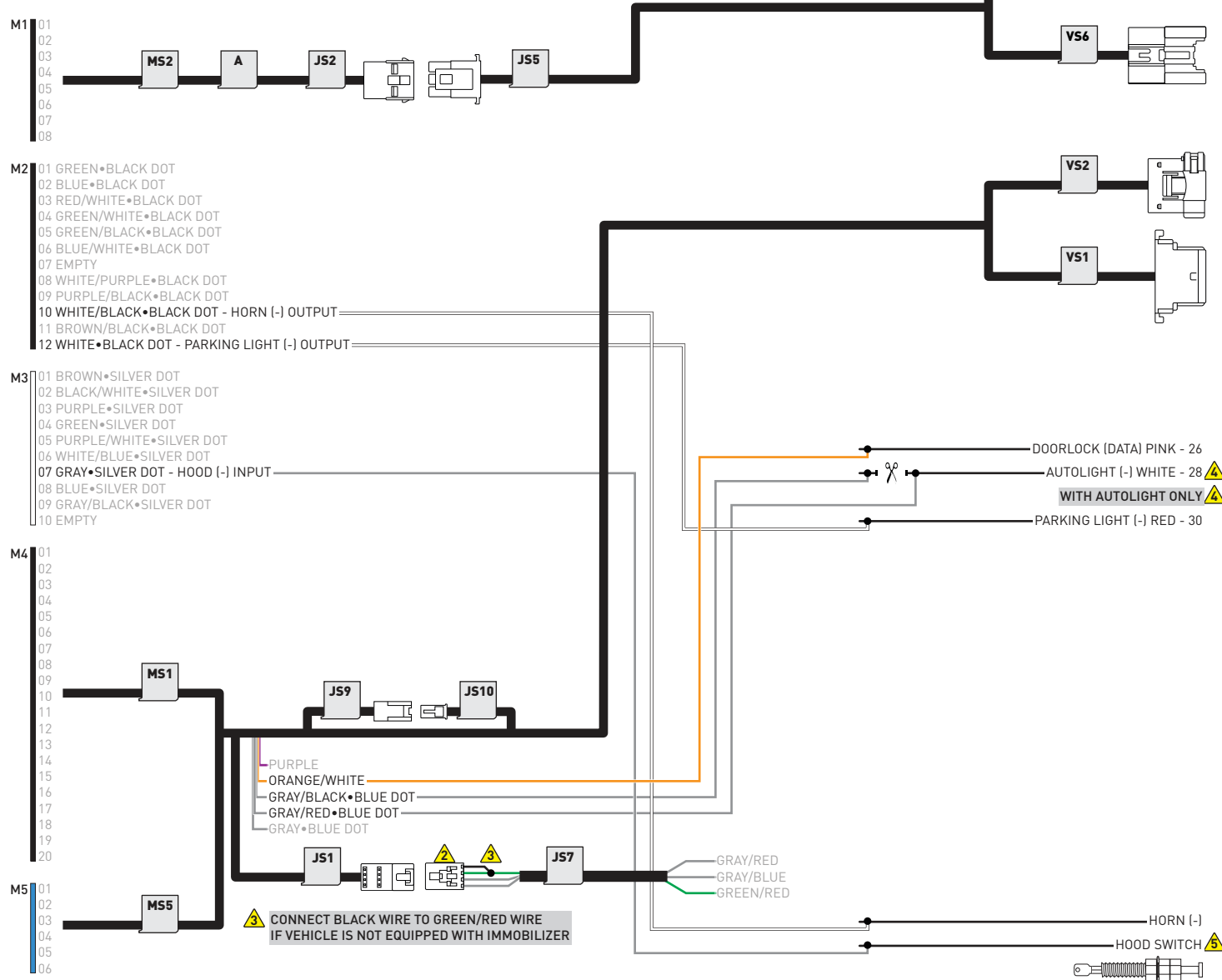

CONNECT BLACK WIRE TO GREEN/RED WIRE IF VEHICLE IS NOT EQUIPPED WITH IMMOBILIZER

IF NOT EQUIPPED WITH AN OEM HOOD PIN:
- INSTALL THE SUPPLIED HOOD SWITCH.

- CHANGE REMOTE STARTER INPUT CONFIGURATION (MENU #7) "4- HOOD INPUT SOURCE" TO "1- ANALOG".

IGNITION SWITCH (A)

1: IGNITION CONNECTOR

1: IGNITION HARNESS

OBDII (B)

1: OBDII CONNECTOR

1: OBDII HOLDER

MAIN BODY ECU (C)

1: GRAY

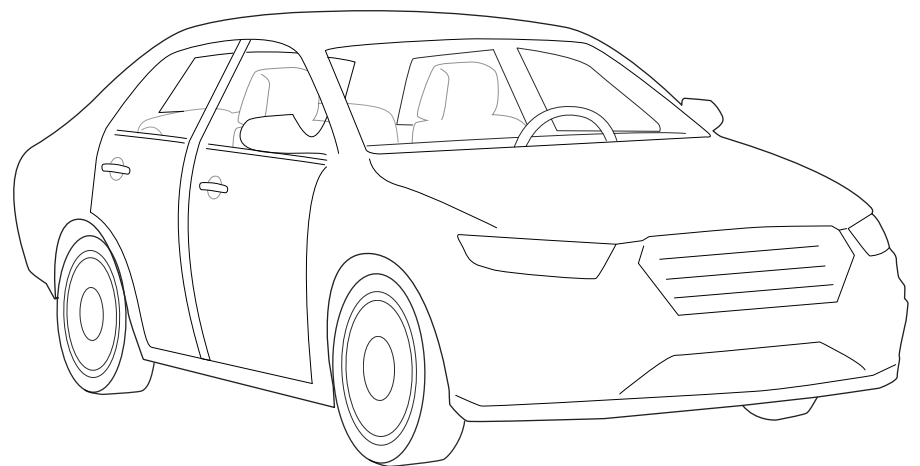
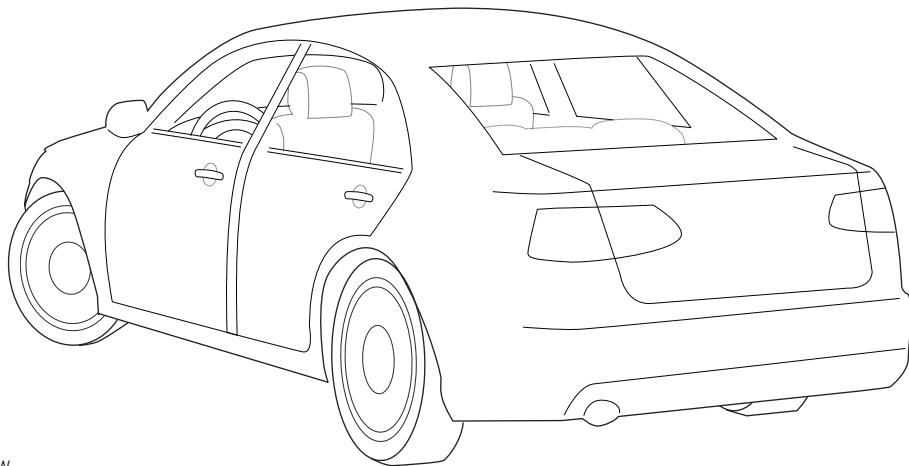
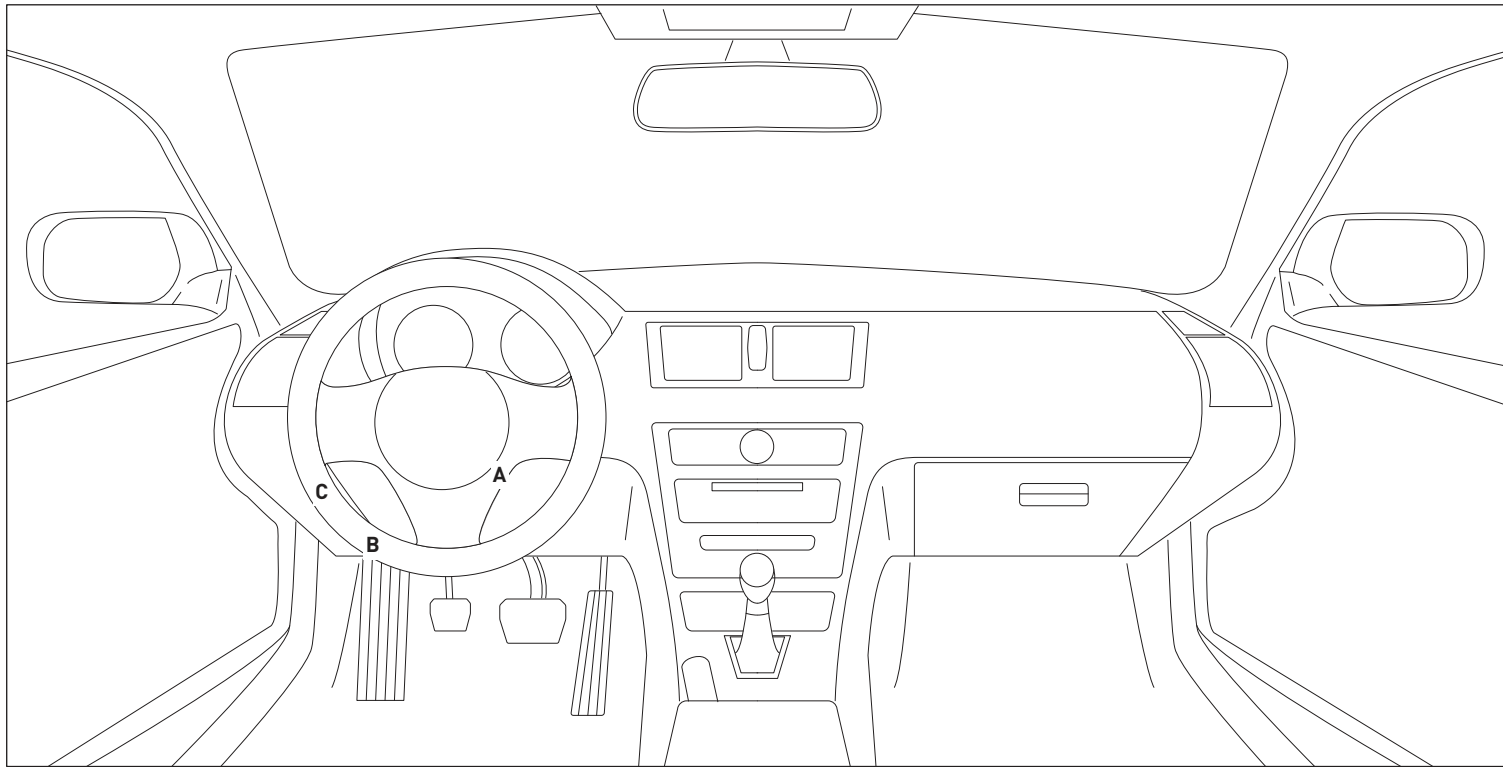

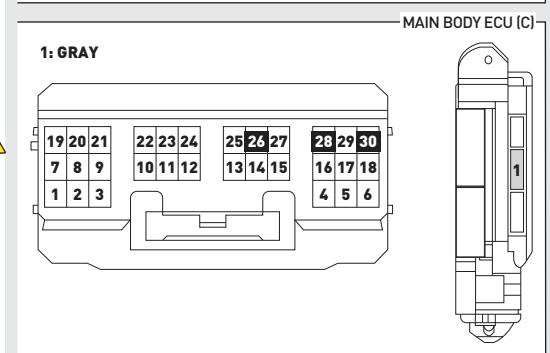
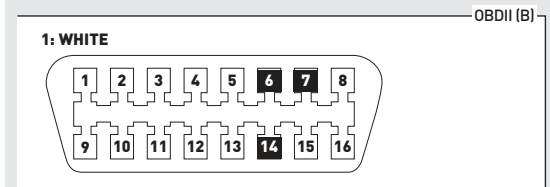
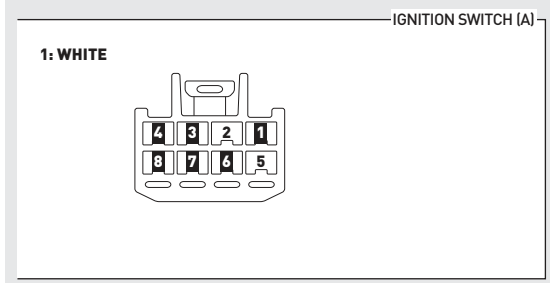
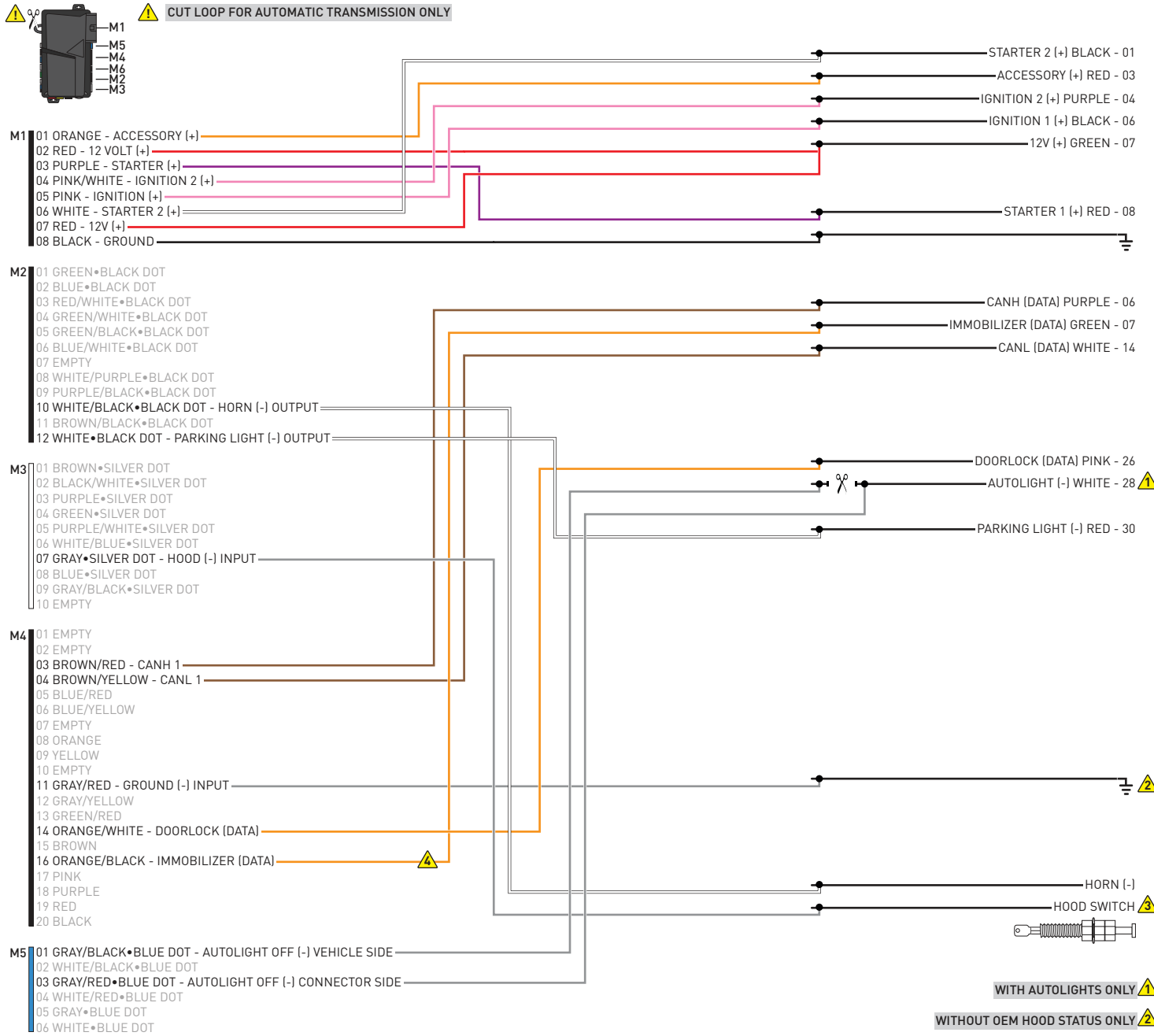

WITH AUTOLIGHTS ONLY ⚠

WITHOUT OEM HOOD STATUS ONLY ⚠

INSTALL THE SUPPLIED HOOD SWITCH IF THE VEHICLE IS NOT EQUIPPED WITH ONE. ⚠

CONNECT ORANGE/BLACK WIRE TO GROUND IF VEHICLE IS NOT EQUIPPED WITH IMMOBILIZER ⚠

01  Use the BLACK key only. DO NOT use the GRAY valet key.

02  Turn key to ON position.

03  Wait, LED 1 will turn solid GREEN for 2 seconds.

04  Turn key to OFF position.

05  START vehicle for 15 seconds.

06  Press and hold the brake pedal.

07  Press and release the module's programming button.

08  Release the brake pedal.

09  Wait, LED 2 will flash GREEN.

10  Module Programming Procedure completed.

>>



All vehicle doors must be closed and locked prior to remote start sequence.

01



Press unlock on OEM or aftermarket remote or request switch.

02



DO NOT PRESS BRAKE PEDAL. Set ignition to ON position. Wait 2 seconds for key validation.

03



Press and release BRAKE pedal.

04



Take over procedure completed.

>>



Failure to follow procedure will result in vehicle engine shutdown.

CHECKLIST - WITH AFTERMARKET KEYFOB	
1	WARNING: Vehicle engine will start many times. Test in a well ventilated area.
2	Close all vehicle doors, hood and trunk.
3	Press the LOCK button once [1x] on the aftermarket keyfob.
	Question 1: Do the doors lock?
<input type="checkbox"/>	YES: Go to next step.
<input type="checkbox"/>	NO: Verify the remote programming, the RF connections and the wired door lock/unlock connections as illustrated in the wiring diagram, if applicable. Repeat the test and call technical support, if the problem persists.
4	Press the UNLOCK button once [1x] on the aftermarket keyfob.
	Question 2: Do the doors unlock?
<input type="checkbox"/>	YES: Go to next step.
<input type="checkbox"/>	NO: Verify the remote programming, the RF connections and the wired door lock/unlock connections as illustrated in the wiring diagram, if applicable. Repeat the test and call technical support, if the problem persists.
5	Press the TRUNK release button once [1x] on the aftermarket keyfob if supported.
	Question 3: Does the trunk or hatch open/unlock?
<input type="checkbox"/>	YES: Close trunk or hatch and go to next step.
<input type="checkbox"/>	NO: Verify the remote programming, the RF connections and the wired trunk/hatch connections as illustrated in the wiring diagram, if applicable. Repeat the test and call technical support, if the problem persists.
6	Press the AUX 1 button once [1x] on the aftermarket keyfob if supported.
	Question 4: Does the driver side sliding door open?
<input type="checkbox"/>	YES: Press the AUX 1 button once [1x] to close the driver sliding door and go to next step.
<input type="checkbox"/>	NO: Verify the remote programming and the RF connections. Repeat the test and call technical support, if the problem persists.
7	Press the AUX 2 button once [1x] on the aftermarket keyfob if supported.
	Question 5: Does the passenger side sliding door open?
<input type="checkbox"/>	YES: Press the AUX 2 button once [1x] to close the passenger sliding door and go to next step.
<input type="checkbox"/>	NO: Verify the remote programming and the RF connections. Repeat the test and call technical support, if the problem persists.
8	Press the START/STOP button once [1x] on the aftermarket keyfob to remote start vehicle.
	Question 6: Does the vehicle remote start?
<input type="checkbox"/>	YES: Go to next step.
<input type="checkbox"/>	NO: Verify the remote programming, the RF connections and check the remote start error codes. Repeat the test and call technical support, if the problem persists.
9	Press the START/STOP button once [1x] on the aftermarket keyfob to shut down vehicle.
	Question 7: Does the vehicle shut down?
<input type="checkbox"/>	YES: Go to next step.
<input type="checkbox"/>	NO: Repeat step. If problem persists, press the brake pedal once [1x] to shut down the vehicle and call technical support.
10	RAP and auto light shutdown test
	Question 8: Did the radio, interior controls and headlights turn off within 60 seconds after remote start shutdown?
<input type="checkbox"/>	YES: Go to next step.
<input type="checkbox"/>	NO: Verify the RAP SHUTDOWN connections as illustrated in the wiring diagram. Repeat the test and call technical support if the problem persists.
11	Open hood.
12	If not already installed, affix the mandatory orange warning sticker under the hood and proceed to next step.
13	Press the START/STOP button once [1x] on the aftermarket keyfob to remote start vehicle.
	Question 9: Does the vehicle remote start?
<input type="checkbox"/>	YES: The vehicle is not equipped with a factory hood pin. Install a mandatory aftermarket hood switch, then repeat the test.
<input type="checkbox"/>	NO: Go to next step.
14	Close hood.
15	Enter vehicle and close the doors.
16	Press the START/STOP button once [1x] on the aftermarket keyfob to remote start vehicle.
17	Wait for the vehicle to start.
18	Press brake pedal.
	Question 10: Does the vehicle shut down?
<input type="checkbox"/>	YES: Go to next step.
<input type="checkbox"/>	NO: The module does NOT detect the brake pedal signal. Press the START/STOP button once [1x] on the aftermarket keyfob to shut down vehicle, check connection as illustrated in the wiring diagram, if applicable, and call technical support.
19	Exit vehicle.
20	Installation checklist completed.

CHECKLIST - WITH OEM KEYFOB	
1	WARNING: Vehicle engine will start many times. Test in a well ventilated area.
2	Close all vehicle doors, hood and trunk.
3	Press LOCK button three times [3x] rapidly on the OEM keyfob to remote start vehicle.
	Question 1: Does the vehicle remote start?
<input type="checkbox"/>	YES: Go to next step.
<input type="checkbox"/>	NO: The module doesn't detect OEM remote lock button from the vehicle communication network. Check all connections, repeat the test and call technical support, if the problem persists.
4	Press LOCK button three times [3x] rapidly on the OEM keyfob to shut down vehicle.
	Question 2: Does the vehicle shut down?
<input type="checkbox"/>	YES: Go to next step.
<input type="checkbox"/>	NO: Repeat step. If the problem persists, press on the brake pedal once [1x] to shut down the vehicle and call technical support.
5	RAP Shutdown test
	Question 3: Did the radio, interior controls, and headlights turn off within 60 seconds after remote start shutdown?
<input type="checkbox"/>	YES: Go to next step.
<input type="checkbox"/>	NO: Verify the RAP SHUTDOWN connections as illustrated in the wiring diagram. Repeat the test and call technical support, if the problem persists.
6	Open hood.
7	If not already installed, affix the mandatory orange warning sticker under the hood and proceed to next step.
8	Press LOCK button three times [3x] rapidly on the OEM keyfob to remote start vehicle.
	Question 4: Does the vehicle remote start?
<input type="checkbox"/>	YES: The vehicle is not equipped with a factory hood pin. Install a mandatory aftermarket hood switch, then repeat the test.
<input type="checkbox"/>	NO: Go to next step.
9	Close hood.
10	Enter vehicle and close the doors.
11	Press LOCK button three times [3x] rapidly on the OEM keyfob to remote start vehicle.
12	Wait for the vehicle to start.
13	Press brake pedal.
	Question 5: Does the vehicle shut down?
<input type="checkbox"/>	YES: Go to next step.
<input type="checkbox"/>	NO: The module does NOT detect the brake pedal signal. Press LOCK button three times [3x] rapidly on the OEM keyfob to shut down, check the brake connection as illustrated in the wiring diagram, if applicable, and call technical support.
14	Exit vehicle.
15	Installation checklist completed.

COMPUSTAR®

INSTALL GUIDE

2010-2011 TOYOTA CAMRY 80-BIT STD KEY AT



DOCUMENT NUMBER

REVISION DATE

20180926

FIRMWARE

COM-RSA-TL5-[RS1B-DC3]

HARDWARE

RS1B-DC3

ACCESSORIES

ATTENTION: TO COMPLETE THIS INSTALLATION SOME ACCESSORIES MAY BE REQUIRED. VISIT OUR WEBSITE TO SEE ALL THE REQUIRED ACCESSORIES FOR YOUR VEHICLE.

TERMS OF USE

Automotive Data Solutions Inc. ("ADS") products are strictly intended for installation by Certified Technicians who are employed by a registered business specialized in the installation of automotive aftermarket electronics products. Prior to beginning installation of an ADS product in a vehicle, it is the Certified Technician's responsibility to review the most current Product Guide, Install Guide and vehicle-specific notes available in Weblink®. ADS is not responsible for any damages whatsoever, including but not limited to any consequential damages, incidental damages, damages for loss of time, loss of earnings, loss of profit, commercial loss, loss of economic opportunity and the like that may or may not have resulted from the use, misuse, improper installation or operation of its products. ADS reserves itself the right to suspend any Weblink® account without notice and decline to offer technical support to non-Certified Technicians, non-compliant Certified Technicians or end users.

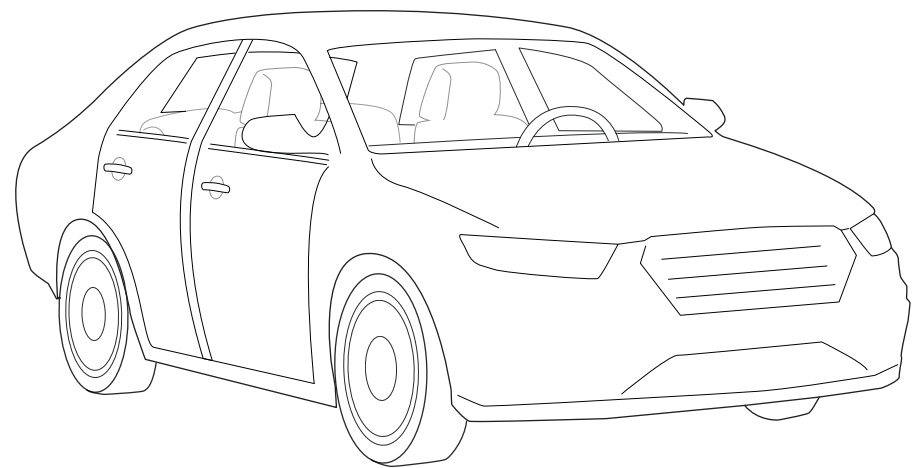
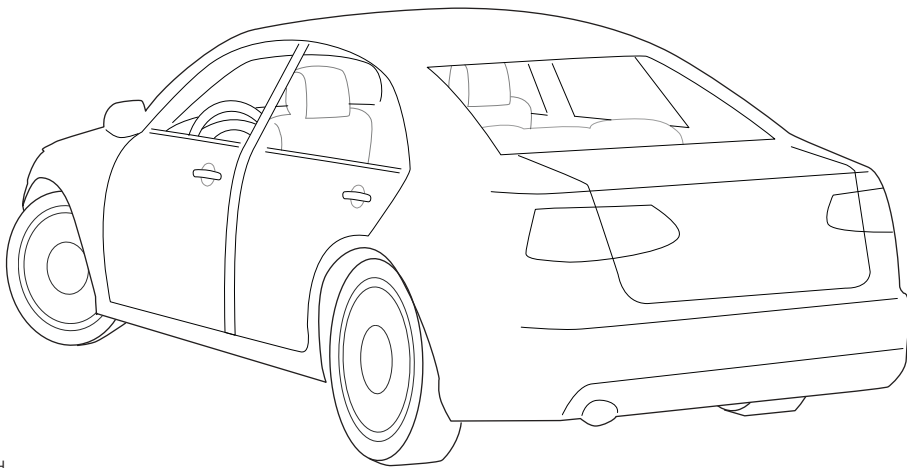
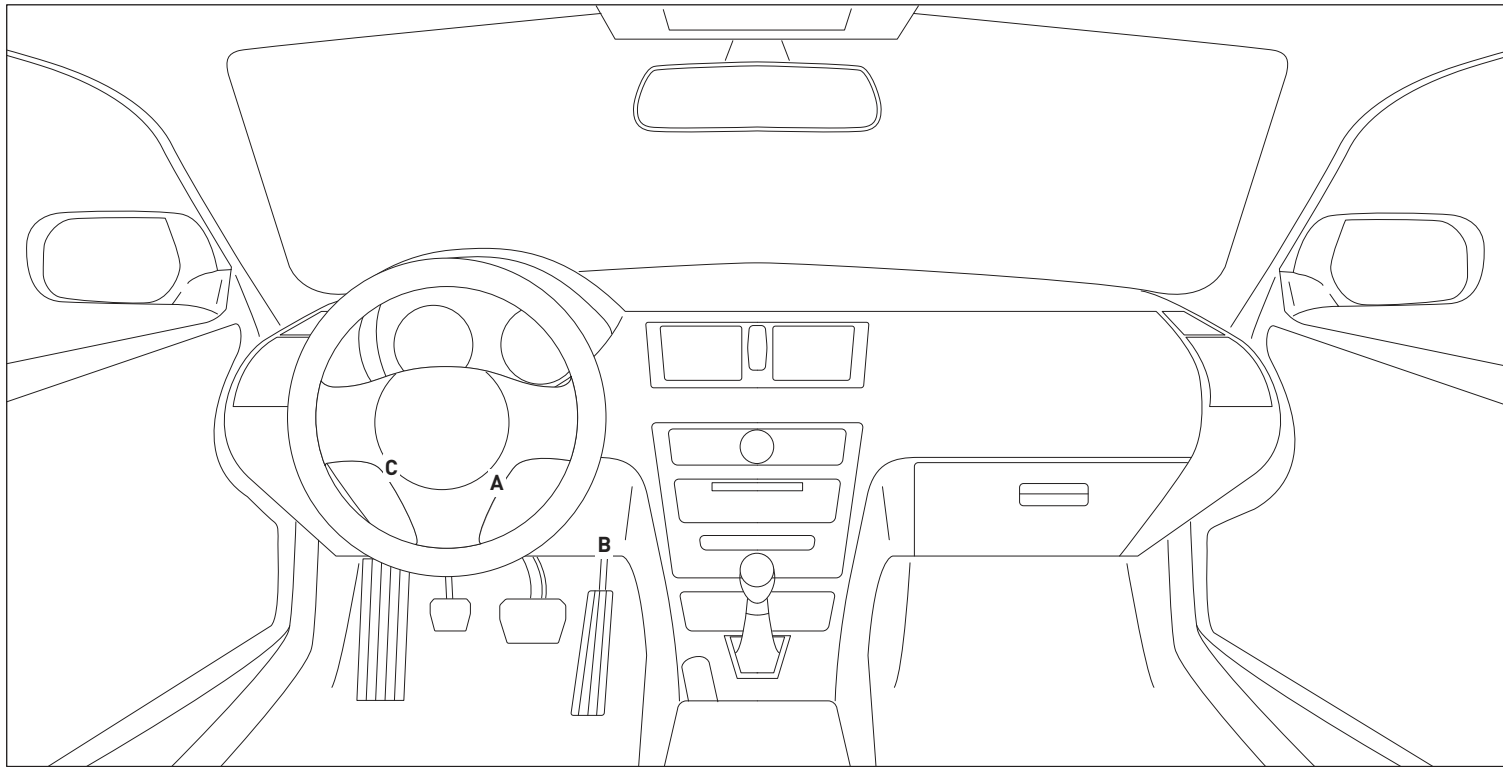

- CUT LOOP FOR AUTOMATIC TRANSMISSION ONLY
- SOME PARTS OF THE T-HARNESS (MS4-C, MS2-A, VS3/VS4 AND JS8) ARE NOT USED IN THIS INSTALL DO NOT CONNECT THEM.
- JS7 IS NOT USED IF THE VEHICLE IS EQUIPPED WITH AN IMMOBILIZER

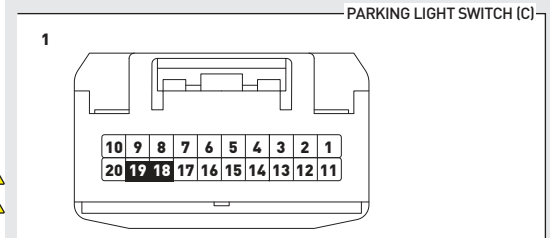
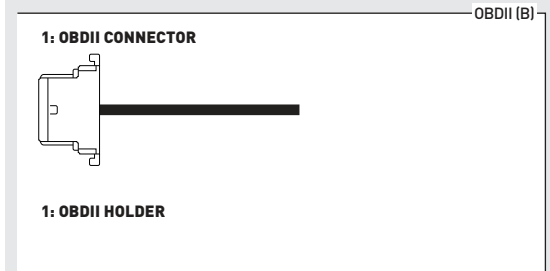
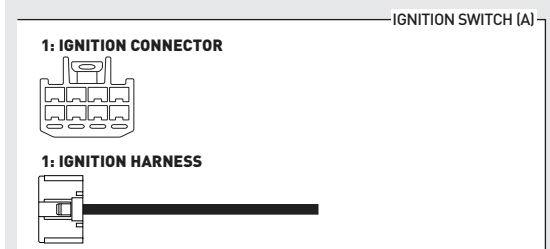
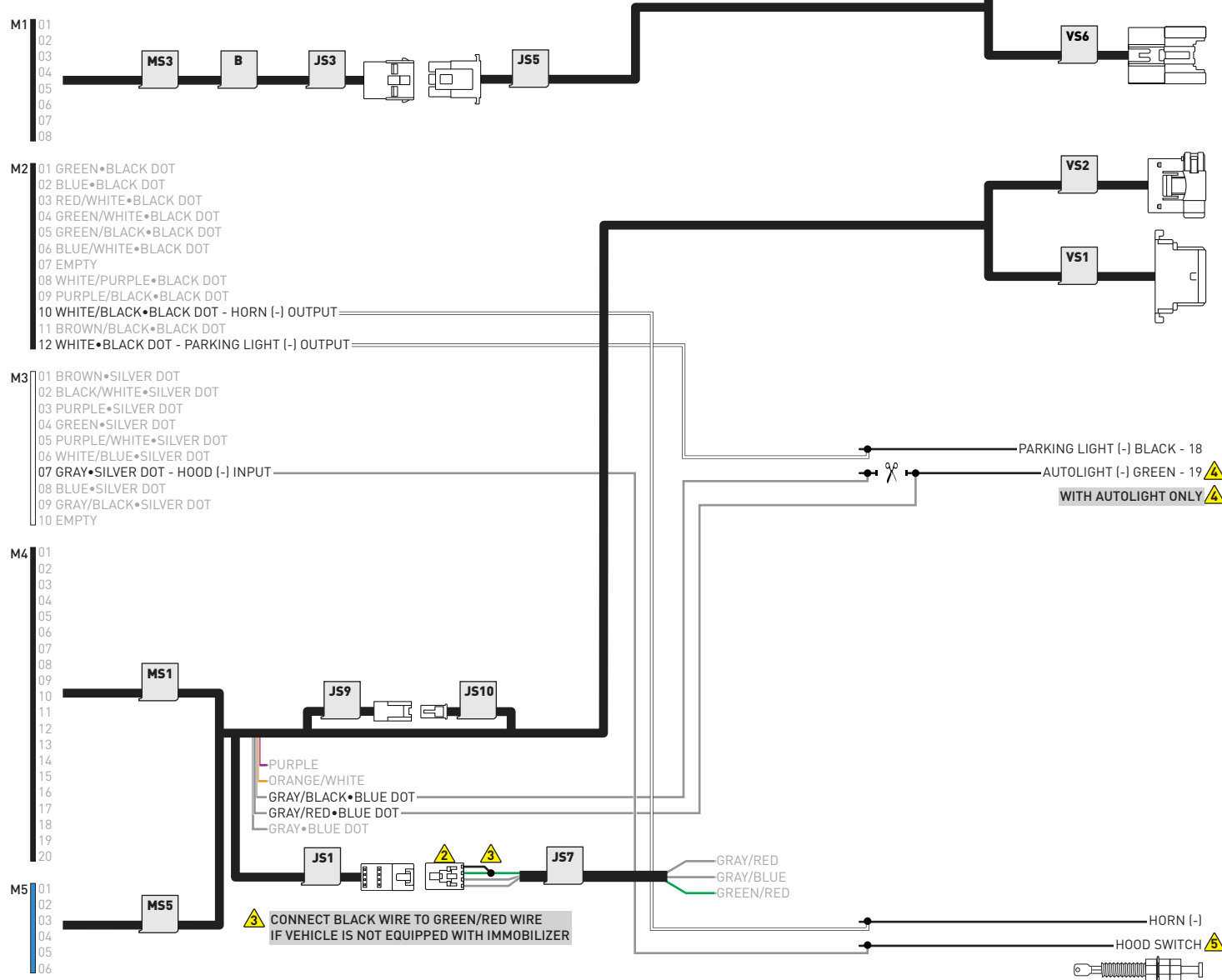

3 CONNECT BLACK WIRE TO GREEN/RED WIRE IF VEHICLE IS NOT EQUIPPED WITH IMMOBILIZER

5 IF NOT EQUIPPED WITH AN OEM HOOD PIN: - INSTALL THE SUPPLIED HOOD SWITCH.
- CHANGE REMOTE STARTER INPUT CONFIGURATION (MENU #7) "4- HOOD INPUT SOURCE" TO "1- ANALOG".

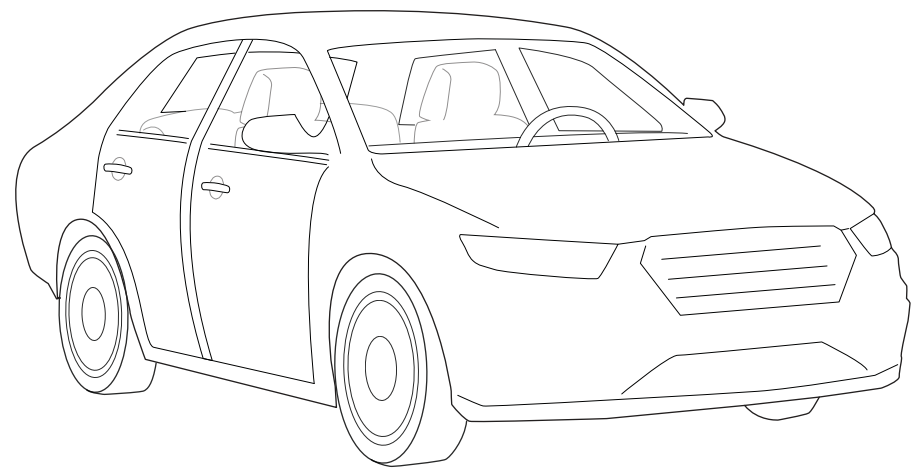
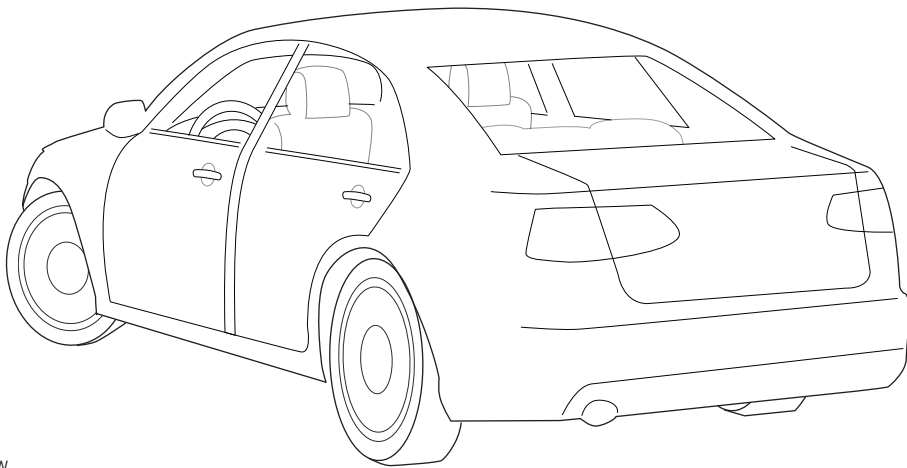
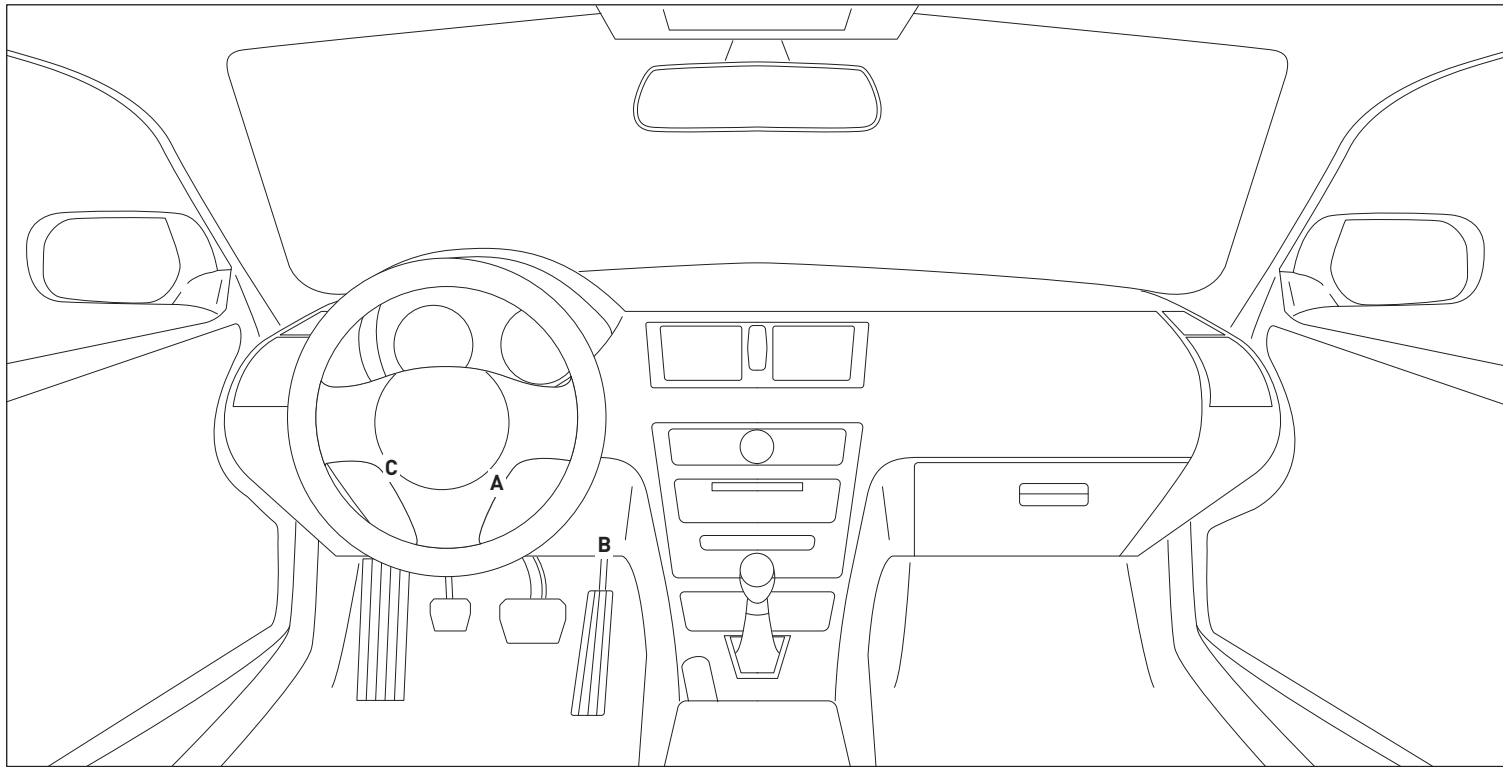

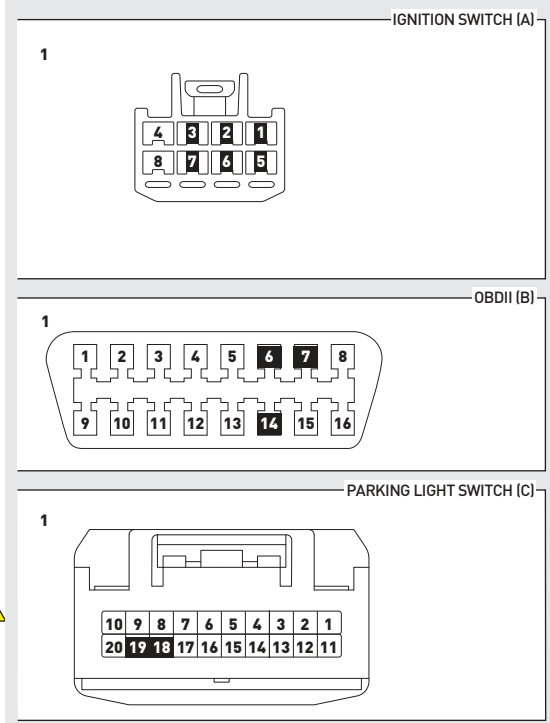
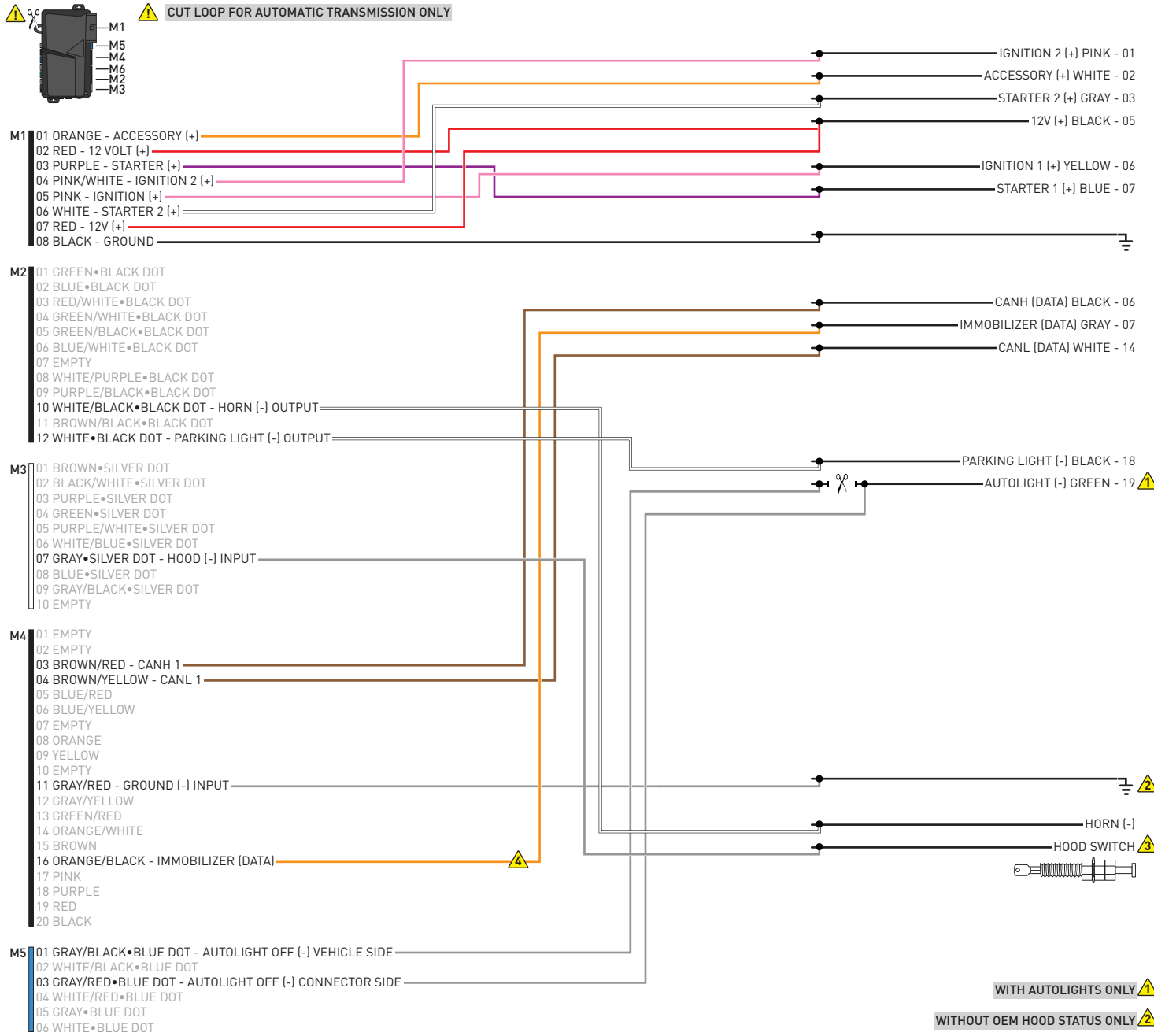

WITH AUTOLIGHTS ONLY ⚠

WITHOUT OEM HOOD STATUS ONLY ⚠

INSTALL THE SUPPLIED HOOD SWITCH IF THE VEHICLE IS NOT EQUIPPED WITH ONE. ⚠

CONNECT ORANGE/BLACK WIRE TO GROUND IF VEHICLE IS NOT EQUIPPED WITH IMMOBILIZER ⚠

01  Use the BLACK key only. DO NOT use the GRAY valet key.

02  Turn key to ON position.

03  Wait, LED 1 will turn solid GREEN for 2 seconds.

04  Turn key to OFF position.

05  START vehicle for 15 seconds.

06  Press and hold the brake pedal.

07  Press and release the module's programming button.

08  Release the brake pedal.

09  Wait, LED 2 will flash GREEN.

10  Module Programming Procedure completed.

>>



All vehicle doors must be closed and locked prior to remote start sequence.

01



Press unlock on OEM or aftermarket remote or request switch.

02



DO NOT PRESS BRAKE PEDAL. Set ignition to ON position. Wait 2 seconds for key validation.

03



Press and release BRAKE pedal.

04



Take over procedure completed.

>>



Failure to follow procedure will result in vehicle engine shutdown.

CHECKLIST - WITH AFTERMARKET KEYFOB

1	WARNING: Vehicle engine will start many times. Test in a well ventilated area.
2	Close all vehicle doors, hood and trunk.
3	Press the LOCK button once [1x] on the aftermarket keyfob.
	Question 1: Do the doors lock?
<input type="checkbox"/>	YES: Go to next step.
<input type="checkbox"/>	NO: Verify the remote programming, the RF connections and the wired door lock/unlock connections as illustrated in the wiring diagram, if applicable. Repeat the test and call technical support, if the problem persists.
4	Press the UNLOCK button once [1x] on the aftermarket keyfob.
	Question 2: Do the doors unlock?
<input type="checkbox"/>	YES: Go to next step.
<input type="checkbox"/>	NO: Verify the remote programming, the RF connections and the wired door lock/unlock connections as illustrated in the wiring diagram, if applicable. Repeat the test and call technical support, if the problem persists.
5	Press the TRUNK release button once [1x] on the aftermarket keyfob if supported.
	Question 3: Does the trunk or hatch open/unlock?
<input type="checkbox"/>	YES: Close trunk or hatch and go to next step.
<input type="checkbox"/>	NO: Verify the remote programming, the RF connections and the wired trunk/hatch connections as illustrated in the wiring diagram, if applicable. Repeat the test and call technical support, if the problem persists.
6	Press the AUX 1 button once [1x] on the aftermarket keyfob if supported.
	Question 4: Does the driver side sliding door open?
<input type="checkbox"/>	YES: Press the AUX 1 button once [1x] to close the driver sliding door and go to next step.
<input type="checkbox"/>	NO: Verify the remote programming and the RF connections. Repeat the test and call technical support, if the problem persists.
7	Press the AUX 2 button once [1x] on the aftermarket keyfob if supported.
	Question 5: Does the passenger side sliding door open?
<input type="checkbox"/>	YES: Press the AUX 2 button once [1x] to close the passenger sliding door and go to next step.
<input type="checkbox"/>	NO: Verify the remote programming and the RF connections. Repeat the test and call technical support, if the problem persists.
8	Press the START/STOP button once [1x] on the aftermarket keyfob to remote start vehicle.
	Question 6: Does the vehicle remote start?
<input type="checkbox"/>	YES: Go to next step.
<input type="checkbox"/>	NO: Verify the remote programming, the RF connections and check the remote start error codes. Repeat the test and call technical support, if the problem persists.

9	Press the START/STOP button once [1x] on the aftermarket keyfob to shut down vehicle.
	Question 7: Does the vehicle shut down?
<input type="checkbox"/>	YES: Go to next step.
<input type="checkbox"/>	NO: Repeat step. If problem persists, press the brake pedal once [1x] to shut down the vehicle and call technical support.
10	RAP and auto light shutdown test
	Question 8: Did the radio, interior controls and headlights turn off within 60 seconds after remote start shutdown?
<input type="checkbox"/>	YES: Go to next step.
<input type="checkbox"/>	NO: Verify the RAP SHUTDOWN connections as illustrated in the wiring diagram. Repeat the test and call technical support if the problem persists.
11	Open hood.
12	If not already installed, affix the mandatory orange warning sticker under the hood and proceed to next step.
13	Press the START/STOP button once [1x] on the aftermarket keyfob to remote start vehicle.
	Question 9: Does the vehicle remote start?
<input type="checkbox"/>	YES: The vehicle is not equipped with a factory hood pin. Install a mandatory aftermarket hood switch, then repeat the test.
<input type="checkbox"/>	NO: Go to next step.
14	Close hood.
15	Enter vehicle and close the doors.
16	Press the START/STOP button once [1x] on the aftermarket keyfob to remote start vehicle.
17	Wait for the vehicle to start.
18	Press brake pedal.
	Question 10: Does the vehicle shut down?
<input type="checkbox"/>	YES: Go to next step.
<input type="checkbox"/>	NO: The module does NOT detect the brake pedal signal. Press the START/STOP button once [1x] on the aftermarket keyfob to shut down vehicle, check connection as illustrated in the wiring diagram, if applicable, and call technical support.
19	Exit vehicle.
20	Installation checklist completed.

CHECKLIST - WITH OEM KEYFOB	
1	WARNING: Vehicle engine will start many times. Test in a well ventilated area.
2	Close all vehicle doors, hood and trunk.
3	Press LOCK button three times [3x] rapidly on the OEM keyfob to remote start vehicle.
	Question 1: Does the vehicle remote start?
<input type="checkbox"/>	YES: Go to next step.
<input type="checkbox"/>	NO: The module doesn't detect OEM remote lock button from the vehicle communication network. Check all connections, repeat the test and call technical support, if the problem persists.
4	Press LOCK button three times [3x] rapidly on the OEM keyfob to shut down vehicle.
	Question 2: Does the vehicle shut down?
<input type="checkbox"/>	YES: Go to next step.
<input type="checkbox"/>	NO: Repeat step. If the problem persists, press on the brake pedal once [1x] to shut down the vehicle and call technical support.
5	RAP Shutdown test
	Question 3: Did the radio, interior controls, and headlights turn off within 60 seconds after remote start shutdown?
<input type="checkbox"/>	YES: Go to next step.
<input type="checkbox"/>	NO: Verify the RAP SHUTDOWN connections as illustrated in the wiring diagram. Repeat the test and call technical support, if the problem persists.
6	Open hood.
7	If not already installed, affix the mandatory orange warning sticker under the hood and proceed to next step.
8	Press LOCK button three times [3x] rapidly on the OEM keyfob to remote start vehicle.
	Question 4: Does the vehicle remote start?
<input type="checkbox"/>	YES: The vehicle is not equipped with a factory hood pin. Install a mandatory aftermarket hood switch, then repeat the test.
<input type="checkbox"/>	NO: Go to next step.
9	Close hood.
10	Enter vehicle and close the doors.
11	Press LOCK button three times [3x] rapidly on the OEM keyfob to remote start vehicle.
12	Wait for the vehicle to start.
13	Press brake pedal.
	Question 5: Does the vehicle shut down?
<input type="checkbox"/>	YES: Go to next step.
<input type="checkbox"/>	NO: The module does NOT detect the brake pedal signal. Press LOCK button three times [3x] rapidly on the OEM keyfob to shut down, check the brake connection as illustrated in the wiring diagram, if applicable, and call technical support.
14	Exit vehicle.
15	Installation checklist completed.

COMPUSTAR®

INSTALL GUIDE

2012-2014 TOYOTA CAMRY 80-BIT STD KEY AT



DOCUMENT NUMBER

REVISION DATE

20180926

FIRMWARE

COM-RSA-TL5-[RS1B-DC3]

HARDWARE

RS1B-DC3

ACCESSORIES

ATTENTION: TO COMPLETE THIS INSTALLATION SOME ACCESSORIES MAY BE REQUIRED. VISIT OUR WEBSITE TO SEE ALL THE REQUIRED ACCESSORIES FOR YOUR VEHICLE.

TERMS OF USE

Automotive Data Solutions Inc. ("ADS") products are strictly intended for installation by Certified Technicians who are employed by a registered business specialized in the installation of automotive aftermarket electronics products. Prior to beginning installation of an ADS product in a vehicle, it is the Certified Technician's responsibility to review the most current Product Guide, Install Guide and vehicle-specific notes available in Weblink®. ADS is not responsible for any damages whatsoever, including but not limited to any consequential damages, incidental damages, damages for loss of time, loss of earnings, loss of profit, commercial loss, loss of economic opportunity and the like that may or may not have resulted from the use, misuse, improper installation or operation of its products. ADS reserves itself the right to suspend any Weblink® account without notice and decline to offer technical support to non-Certified Technicians, non-compliant Certified Technicians or end users.

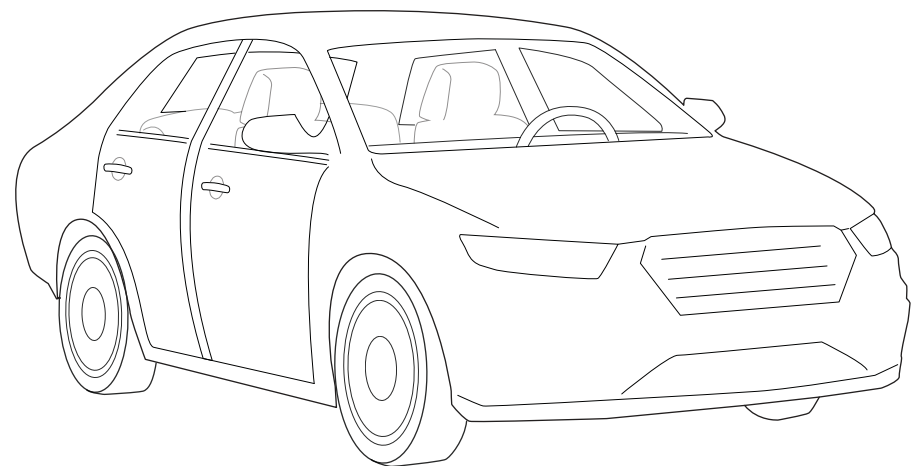
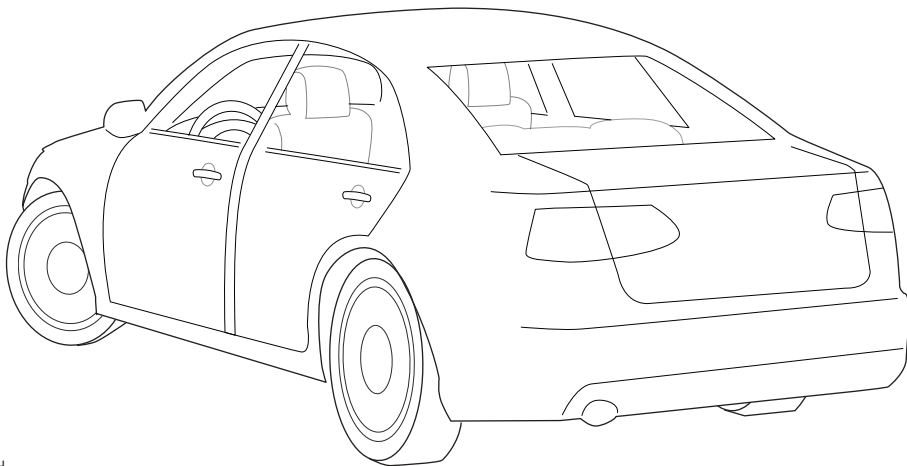
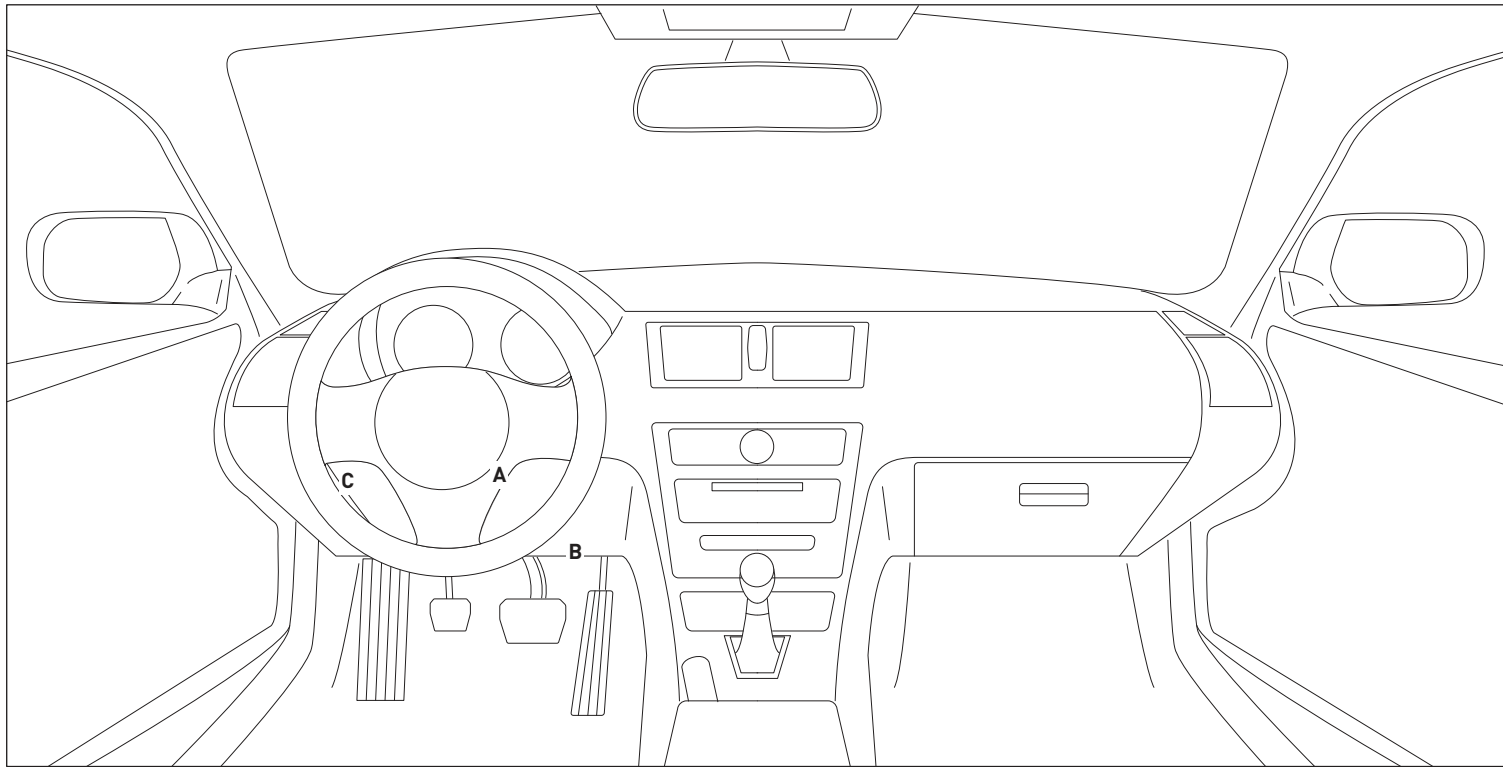

- CUT LOOP FOR AUTOMATIC TRANSMISSION ONLY
- SOME PARTS OF THE T-HARNESS (MS4-C, MS2-A, VS3/VS4 AND JS8) ARE NOT USED IN THIS INSTALL DO NOT CONNECT THEM.
- JS7 IS NOT USED IF THE VEHICLE IS EQUIPPED WITH AN IMMOBILIZER

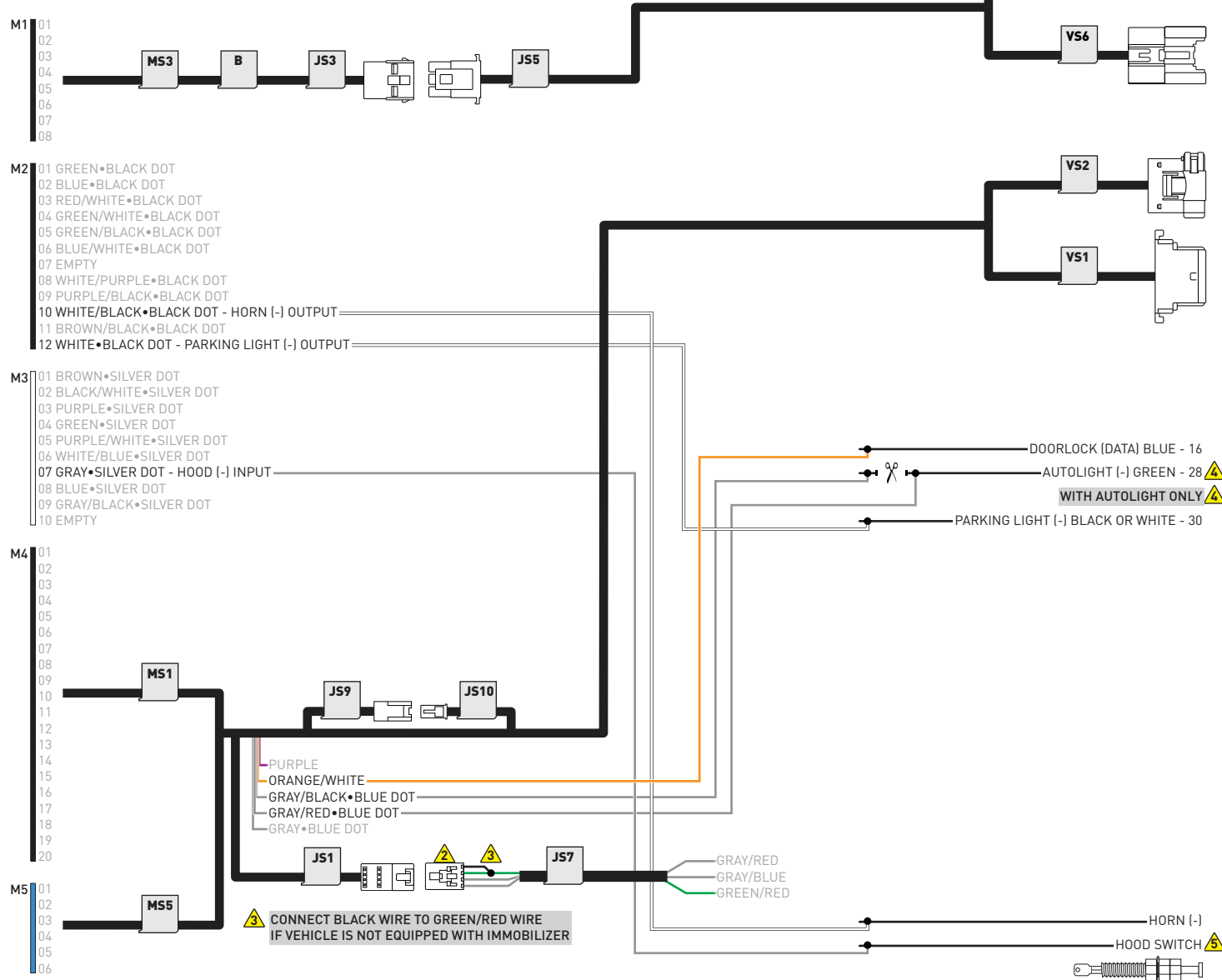

CONNECT BLACK WIRE TO GREEN/RED WIRE IF VEHICLE IS NOT EQUIPPED WITH IMMOBILIZER

IF NOT EQUIPPED WITH AN OEM HOOD PIN:
- INSTALL THE SUPPLIED HOOD SWITCH.
 - CHANGE REMOTE STARTER INPUT CONFIGURATION (MENU #7) "4- HOOD INPUT SOURCE" TO "1- ANALOG".

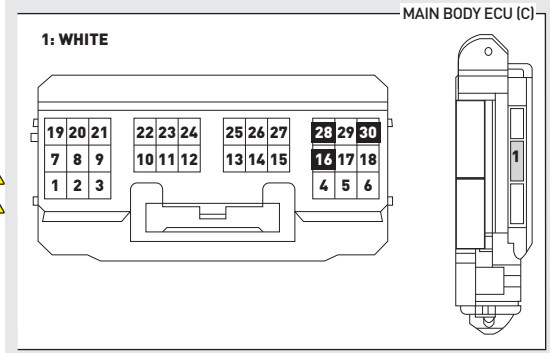
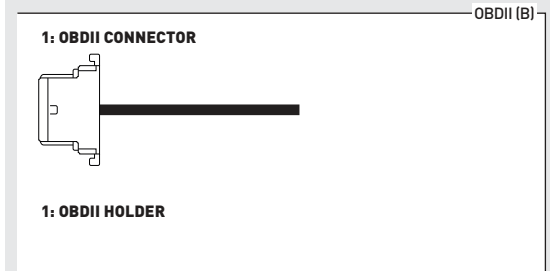
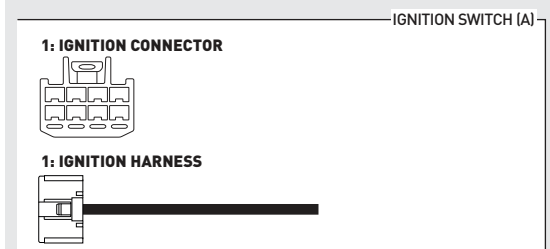

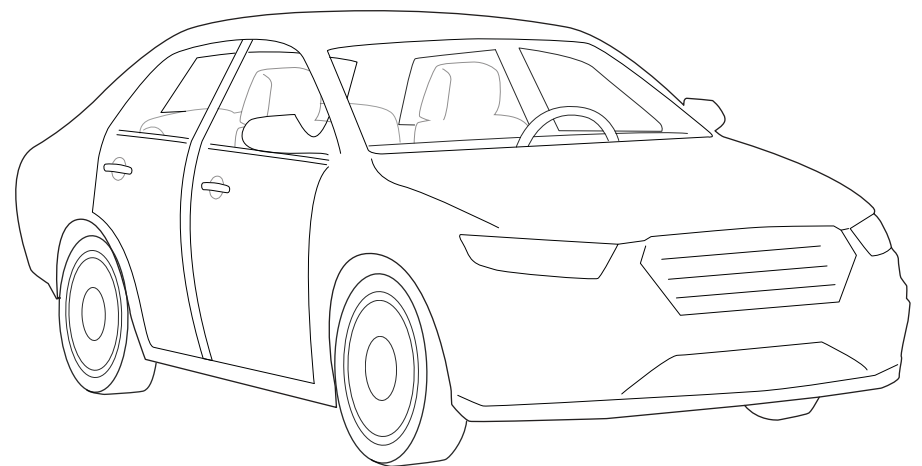
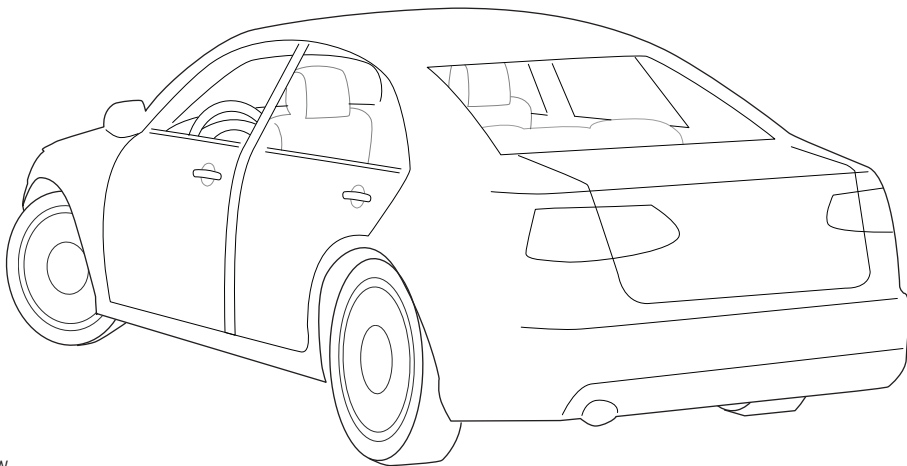
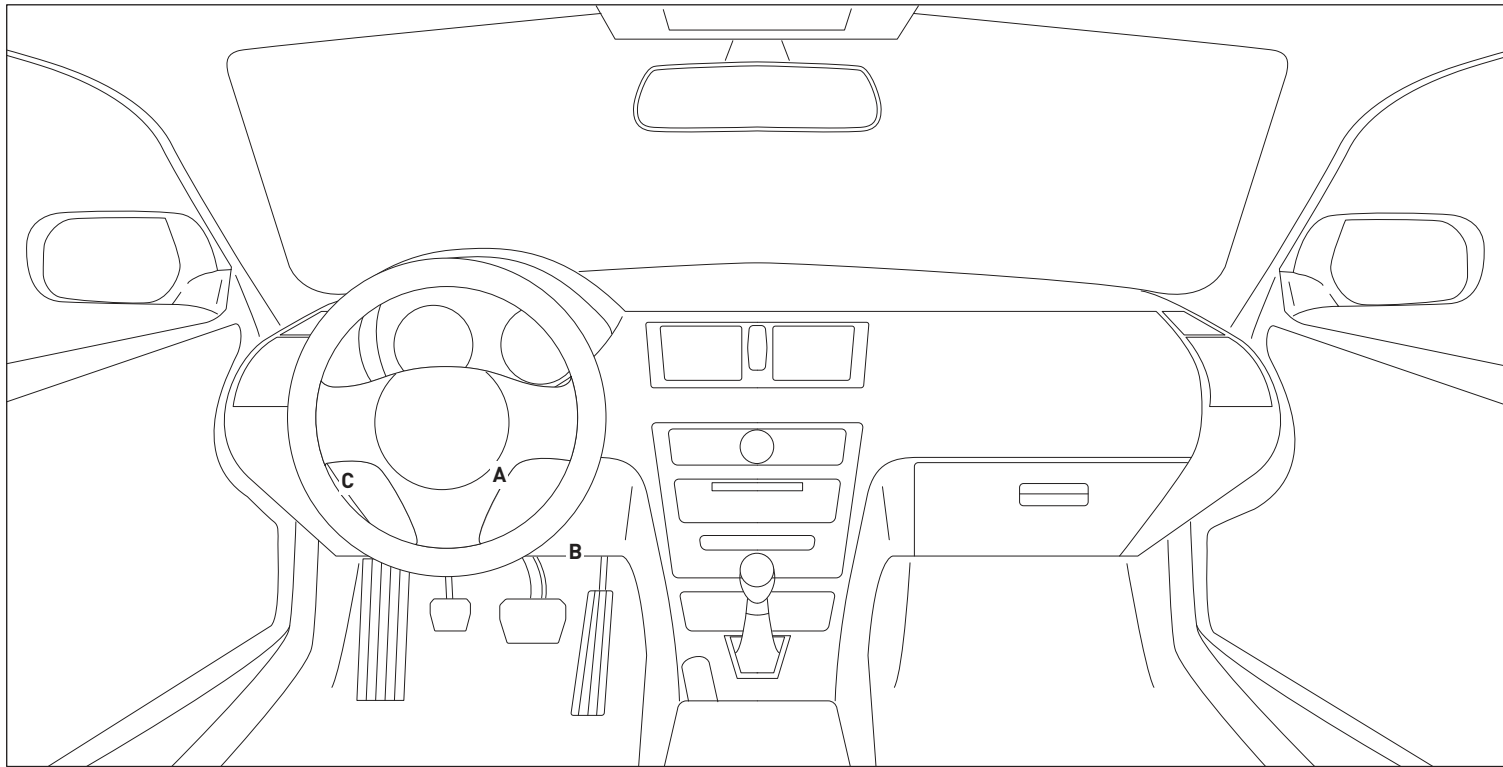

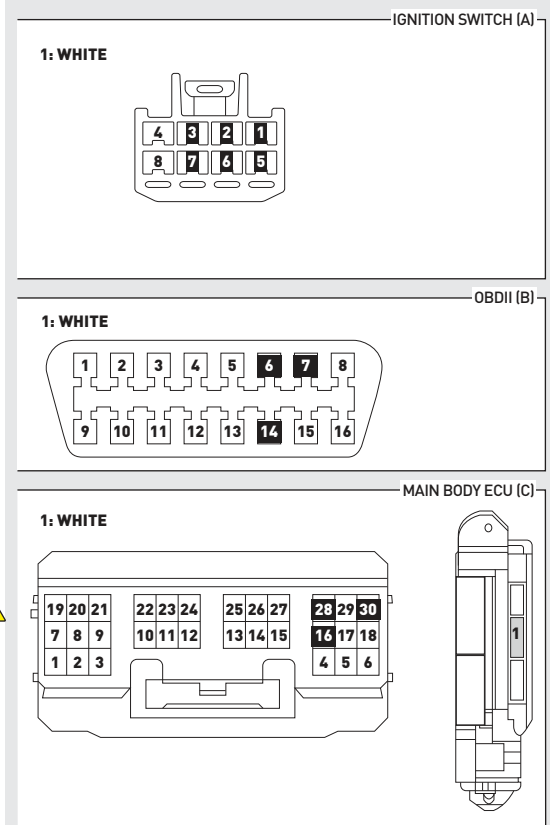
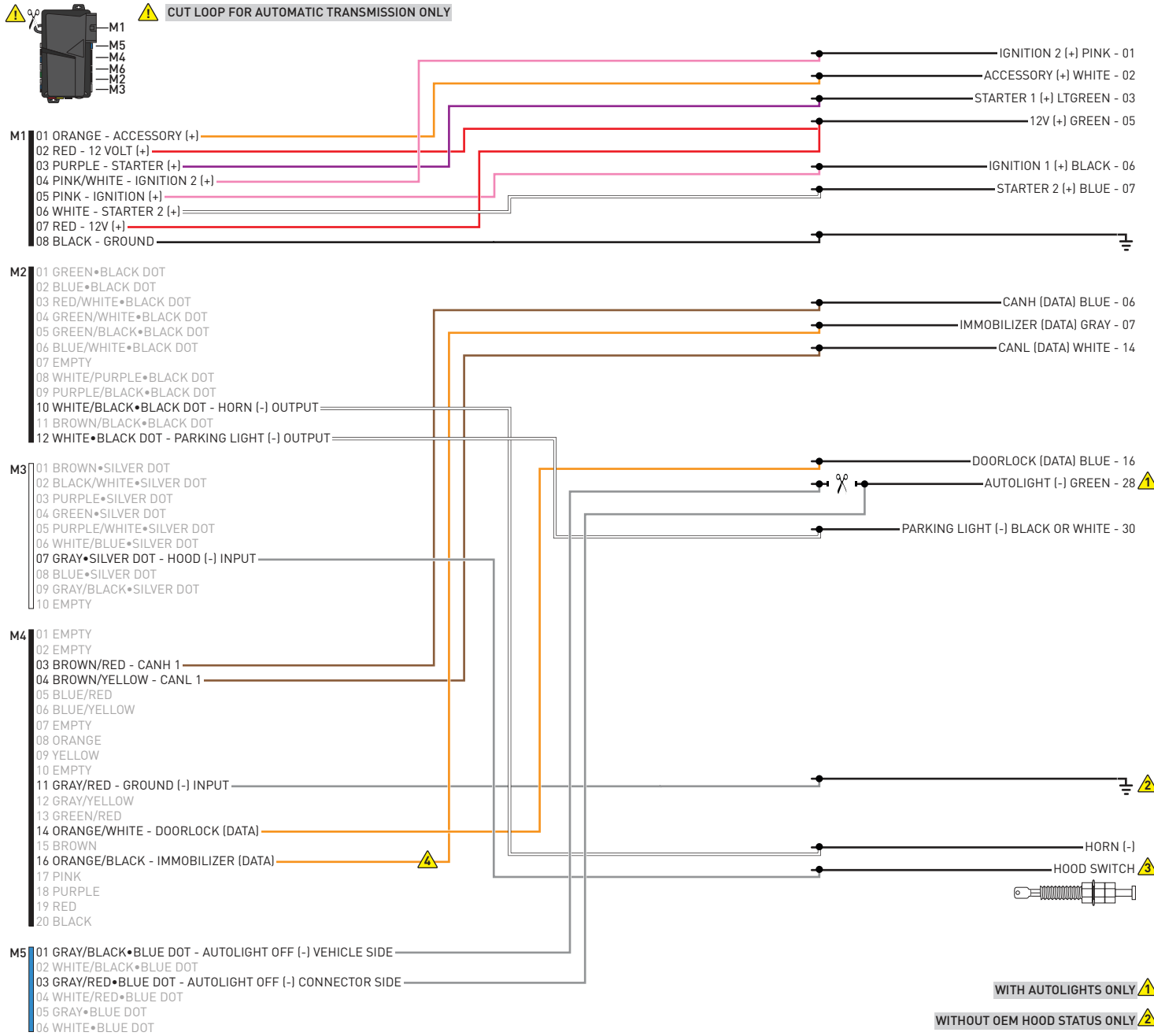

WITH AUTOLIGHTS ONLY ⚠

WITHOUT OEM HOOD STATUS ONLY ⚠

INSTALL THE SUPPLIED HOOD SWITCH IF THE VEHICLE IS NOT EQUIPPED WITH ONE. ⚠

CONNECT ORANGE/BLACK WIRE TO GROUND IF VEHICLE IS NOT EQUIPPED WITH IMMOBILIZER ⚠

01  Use the BLACK key only. DO NOT use the GRAY valet key.

02  Turn key to ON position.

03  Wait, LED 1 will turn solid GREEN for 2 seconds.

04  Turn key to OFF position.

05  START vehicle for 15 seconds.

06  Press and hold the brake pedal.

07  Press and release the module's programming button.

08  Release the brake pedal.

09  Wait, LED 2 will flash GREEN.

10  Module Programming Procedure completed.

>>



All vehicle doors must be closed and locked prior to remote start sequence.

01



Press unlock on OEM or aftermarket remote or request switch.

02



DO NOT PRESS BRAKE PEDAL. Set ignition to ON position. Wait 2 seconds for key validation.

03



Press and release BRAKE pedal.

04



Take over procedure completed.

>>



Failure to follow procedure will result in vehicle engine shutdown.

CHECKLIST - WITH AFTERMARKET KEYFOB

1	WARNING: Vehicle engine will start many times. Test in a well ventilated area.	9	Press the START/STOP button once [1x] on the aftermarket keyfob to shut down vehicle.
2	Close all vehicle doors, hood and trunk.		Question 7: Does the vehicle shut down?
3	Press the LOCK button once [1x] on the aftermarket keyfob.	<input type="checkbox"/>	YES: Go to next step.
	Question 1: Do the doors lock?	<input type="checkbox"/>	NO: Repeat step. If problem persists, press the brake pedal once [1x] to shut down the vehicle and call technical support.
<input type="checkbox"/>	YES: Go to next step.	10	RAP and auto light shutdown test
<input type="checkbox"/>	NO: Verify the remote programming, the RF connections and the wired door lock/unlock connections as illustrated in the wiring diagram, if applicable. Repeat the test and call technical support, if the problem persists.		Question 8: Did the radio, interior controls and headlights turn off within 60 seconds after remote start shutdown?
4	Press the UNLOCK button once [1x] on the aftermarket keyfob.	<input type="checkbox"/>	YES: Go to next step.
	Question 2: Do the doors unlock?	<input type="checkbox"/>	NO: Verify the RAP SHUTDOWN connections as illustrated in the wiring diagram. Repeat the test and call technical support if the problem persists.
<input type="checkbox"/>	YES: Go to next step.	11	Open hood.
<input type="checkbox"/>	NO: Verify the remote programming, the RF connections and the wired door lock/unlock connections as illustrated in the wiring diagram, if applicable. Repeat the test and call technical support, if the problem persists.	12	If not already installed, affix the mandatory orange warning sticker under the hood and proceed to next step.
5	Press the TRUNK release button once [1x] on the aftermarket keyfob if supported.	13	Press the START/STOP button once [1x] on the aftermarket keyfob to remote start vehicle.
	Question 3: Does the trunk or hatch open/unlock?		Question 9: Does the vehicle remote start?
<input type="checkbox"/>	YES: Close trunk or hatch and go to next step.	<input type="checkbox"/>	YES: The vehicle is not equipped with a factory hood pin. Install a mandatory aftermarket hood switch, then repeat the test.
<input type="checkbox"/>	NO: Verify the remote programming, the RF connections and the wired trunk/hatch connections as illustrated in the wiring diagram, if applicable. Repeat the test and call technical support, if the problem persists.	<input type="checkbox"/>	NO: Go to next step.
6	Press the AUX 1 button once [1x] on the aftermarket keyfob if supported.	14	Close hood.
	Question 4: Does the driver side sliding door open?	15	Enter vehicle and close the doors.
<input type="checkbox"/>	YES: Press the AUX 1 button once [1x] to close the driver sliding door and go to next step.	16	Press the START/STOP button once [1x] on the aftermarket keyfob to remote start vehicle.
<input type="checkbox"/>	NO: Verify the remote programming and the RF connections. Repeat the test and call technical support, if the problem persists.	17	Wait for the vehicle to start.
7	Press the AUX 2 button once [1x] on the aftermarket keyfob if supported.	18	Press brake pedal.
	Question 5: Does the passenger side sliding door open?		Question 10: Does the vehicle shut down?
<input type="checkbox"/>	YES: Press the AUX 2 button once [1x] to close the passenger sliding door and go to next step.	<input type="checkbox"/>	YES: Go to next step.
<input type="checkbox"/>	NO: Verify the remote programming and the RF connections. Repeat the test and call technical support, if the problem persists.	<input type="checkbox"/>	NO: The module does NOT detect the brake pedal signal. Press the START/STOP button once [1x] on the aftermarket keyfob to shut down vehicle, check connection as illustrated in the wiring diagram, if applicable, and call technical support.
8	Press the START/STOP button once [1x] on the aftermarket keyfob to remote start vehicle.	19	Exit vehicle.
	Question 6: Does the vehicle remote start?	20	Installation checklist completed.
<input type="checkbox"/>	YES: Go to next step.		
<input type="checkbox"/>	NO: Verify the remote programming, the RF connections and check the remote start error codes. Repeat the test and call technical support, if the problem persists.		

CHECKLIST - WITH OEM KEYFOB	
1	WARNING: Vehicle engine will start many times. Test in a well ventilated area.
2	Close all vehicle doors, hood and trunk.
3	Press LOCK button three times [3x] rapidly on the OEM keyfob to remote start vehicle.
	Question 1: Does the vehicle remote start?
<input type="checkbox"/>	YES: Go to next step.
<input type="checkbox"/>	NO: The module doesn't detect OEM remote lock button from the vehicle communication network. Check all connections, repeat the test and call technical support, if the problem persists.
4	Press LOCK button three times [3x] rapidly on the OEM keyfob to shut down vehicle.
	Question 2: Does the vehicle shut down?
<input type="checkbox"/>	YES: Go to next step.
<input type="checkbox"/>	NO: Repeat step. If the problem persists, press on the brake pedal once [1x] to shut down the vehicle and call technical support.
5	RAP Shutdown test
	Question 3: Did the radio, interior controls, and headlights turn off within 60 seconds after remote start shutdown?
<input type="checkbox"/>	YES: Go to next step.
<input type="checkbox"/>	NO: Verify the RAP SHUTDOWN connections as illustrated in the wiring diagram. Repeat the test and call technical support, if the problem persists.
6	Open hood.
7	If not already installed, affix the mandatory orange warning sticker under the hood and proceed to next step.
8	Press LOCK button three times [3x] rapidly on the OEM keyfob to remote start vehicle.
	Question 4: Does the vehicle remote start?
<input type="checkbox"/>	YES: The vehicle is not equipped with a factory hood pin. Install a mandatory aftermarket hood switch, then repeat the test.
<input type="checkbox"/>	NO: Go to next step.
9	Close hood.
10	Enter vehicle and close the doors.
11	Press LOCK button three times [3x] rapidly on the OEM keyfob to remote start vehicle.
12	Wait for the vehicle to start.
13	Press brake pedal.
	Question 5: Does the vehicle shut down?
<input type="checkbox"/>	YES: Go to next step.
<input type="checkbox"/>	NO: The module does NOT detect the brake pedal signal. Press LOCK button three times [3x] rapidly on the OEM keyfob to shut down, check the brake connection as illustrated in the wiring diagram, if applicable, and call technical support.
14	Exit vehicle.
15	Installation checklist completed.

COMPUSTAR®

INSTALL GUIDE

2012-2013 TOYOTA COROLLA 80-BIT STD KEY AT



DOCUMENT NUMBER

REVISION DATE

20180926

FIRMWARE

COM-RSA-TL5-[RS1B-DC3]

HARDWARE

RS1B-DC3

ACCESSORIES

ATTENTION: TO COMPLETE THIS INSTALLATION SOME ACCESSORIES MAY BE REQUIRED. VISIT OUR WEBSITE TO SEE ALL THE REQUIRED ACCESSORIES FOR YOUR VEHICLE.

TERMS OF USE

Automotive Data Solutions Inc. ("ADS") products are strictly intended for installation by Certified Technicians who are employed by a registered business specialized in the installation of automotive aftermarket electronics products. Prior to beginning installation of an ADS product in a vehicle, it is the Certified Technician's responsibility to review the most current Product Guide, Install Guide and vehicle-specific notes available in Weblink®. ADS is not responsible for any damages whatsoever, including but not limited to any consequential damages, incidental damages, damages for loss of time, loss of earnings, loss of profit, commercial loss, loss of economic opportunity and the like that may or may not have resulted from the use, misuse, improper installation or operation of its products. ADS reserves itself the right to suspend any Weblink® account without notice and decline to offer technical support to non-Certified Technicians, non-compliant Certified Technicians or end users.

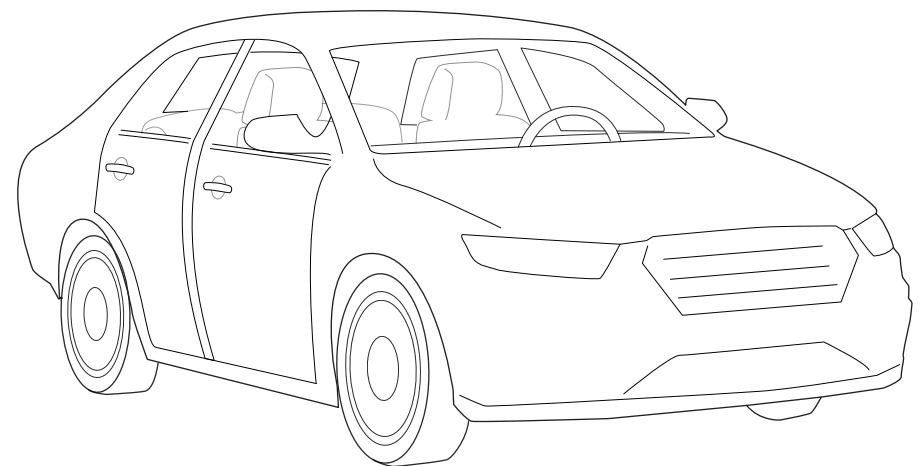
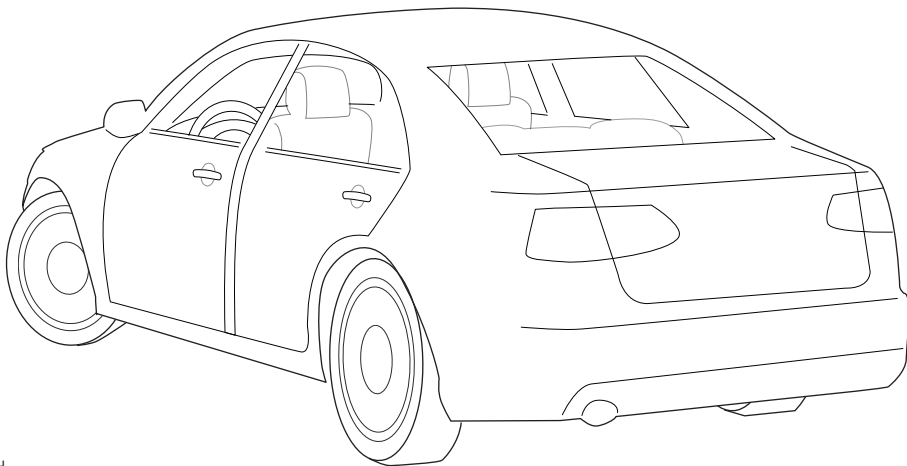
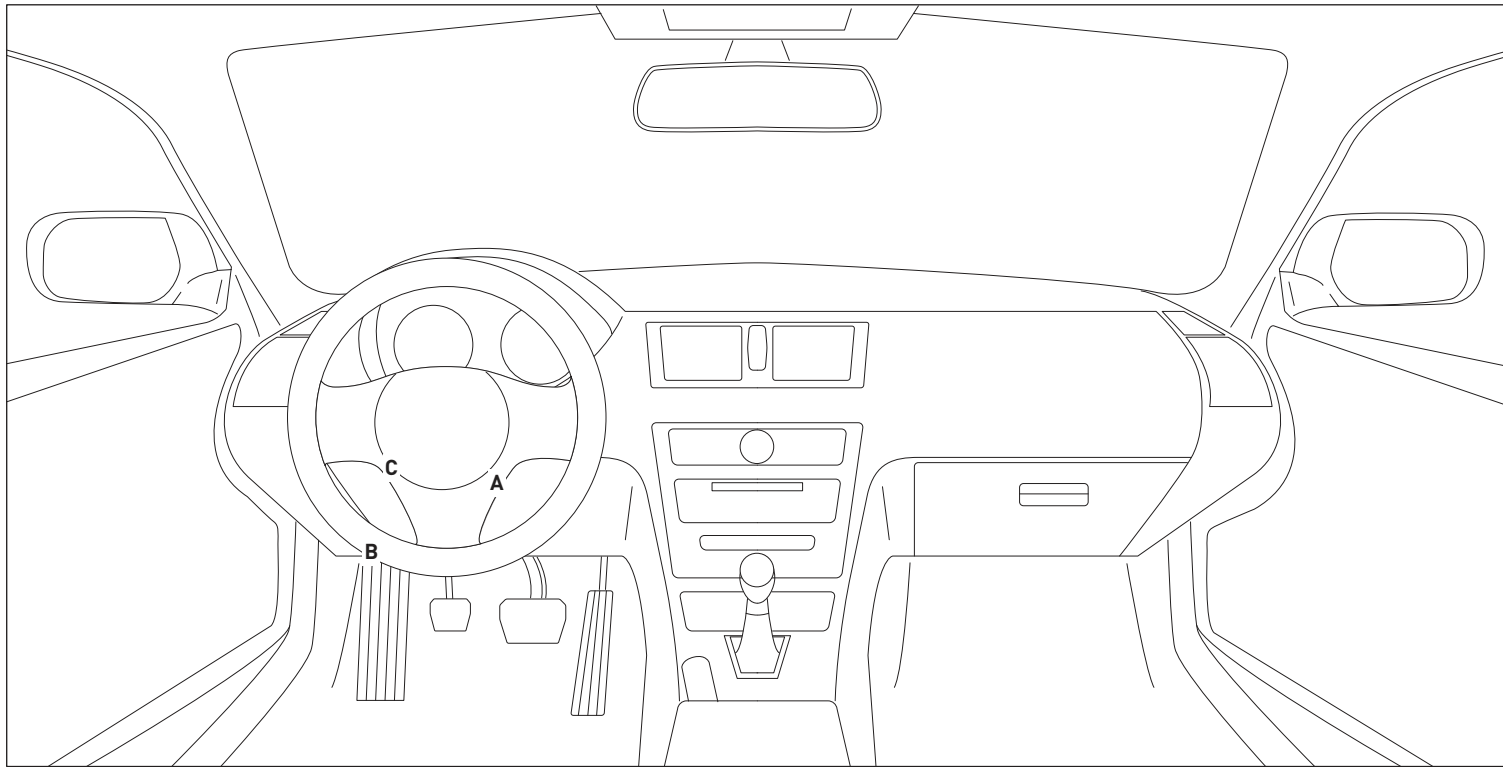

- CUT LOOP FOR AUTOMATIC TRANSMISSION ONLY
- SOME PARTS OF THE T-HARNESS (MS4-C, MS3-B, VS3/VS4 AND JS8) ARE NOT USED IN THIS INSTALL DO NOT CONNECT THEM.
- JS7 IS NOT USED IF THE VEHICLE IS EQUIPPED WITH AN IMMOBILIZER

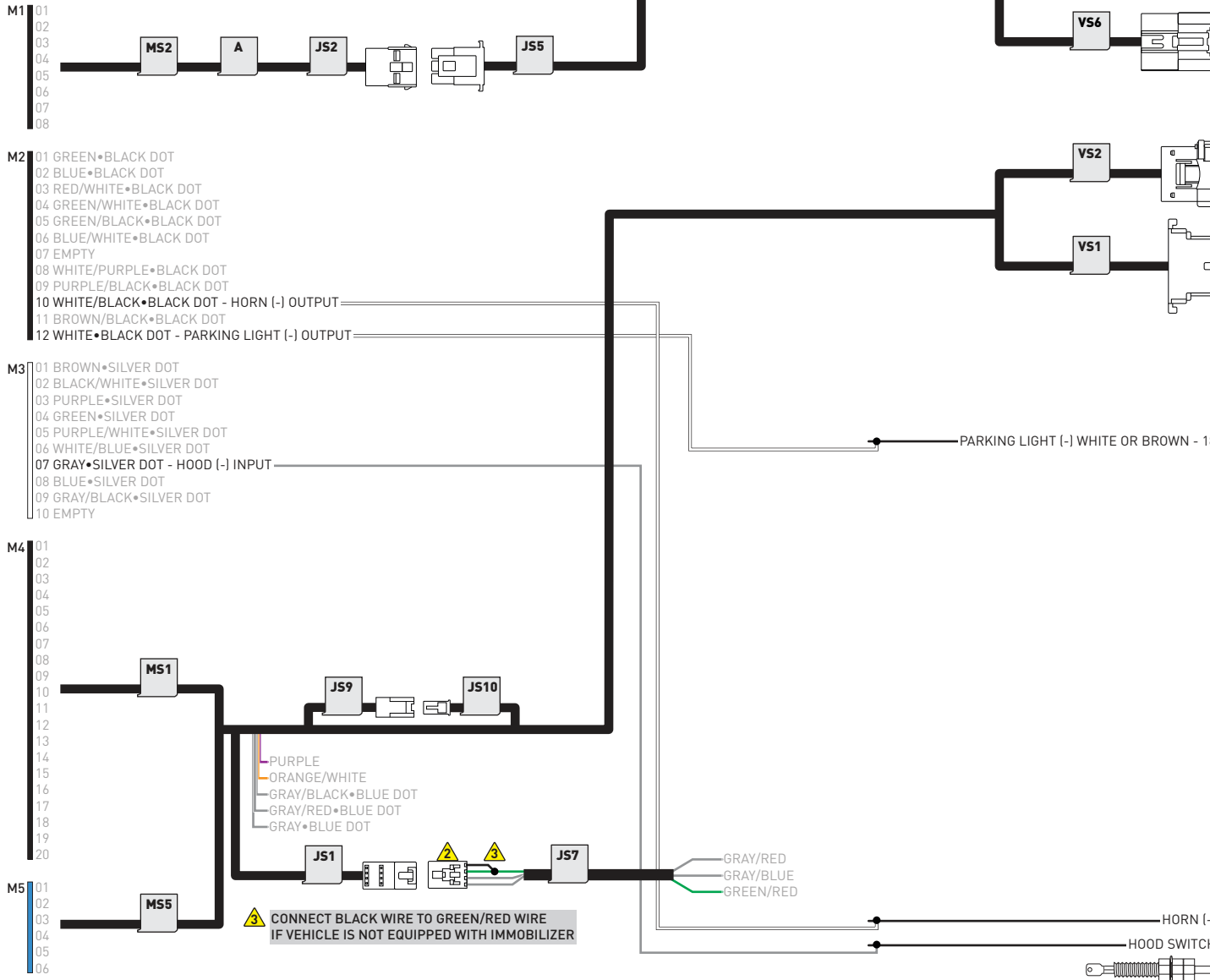

CONNECT BLACK WIRE TO GREEN/RED WIRE IF VEHICLE IS NOT EQUIPPED WITH IMMOBILIZER

IF NOT EQUIPPED WITH AN OEM HOOD PIN:
 - INSTALL THE SUPPLIED HOOD SWITCH.
 - CHANGE REMOTE STARTER INPUT CONFIGURATION (MENU #7) "4- HOOD INPUT SOURCE" TO "1- ANALOG".

IGNITION SWITCH (A)

1: IGNITION CONNECTOR

1: IGNITION HARNESS

OBDII (B)

1: OBDII CONNECTOR

1: OBDII HOLDER

PARKING LIGHT SWITCH (C)

1

10	9	8	7	6	5	4	3	2	1
20	19	18	17	16	15	14	13	12	11

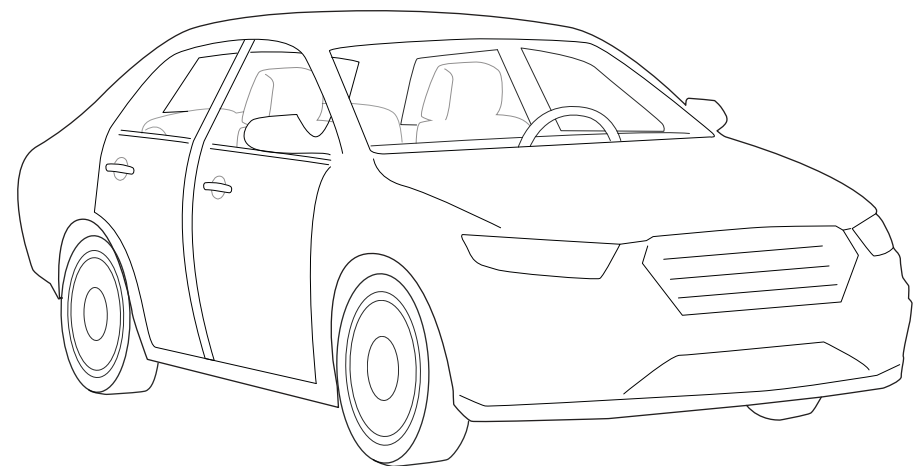
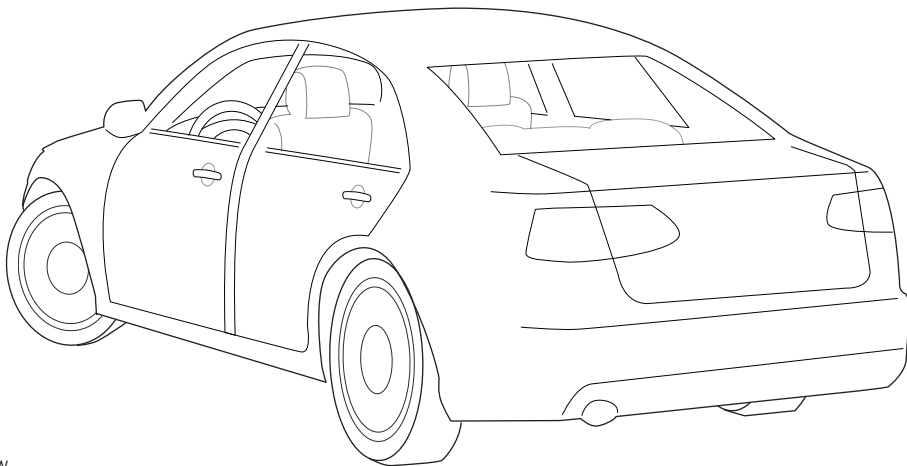
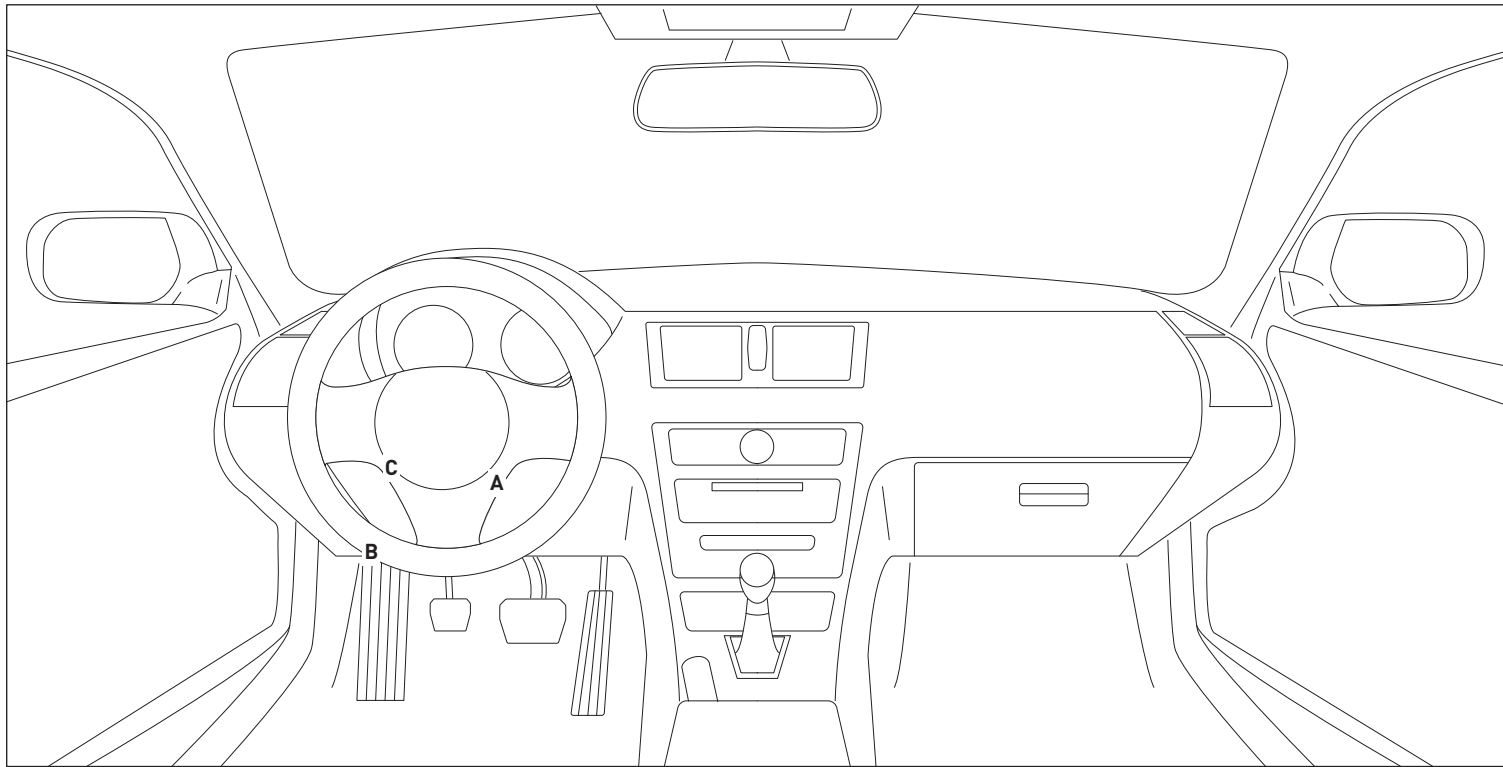

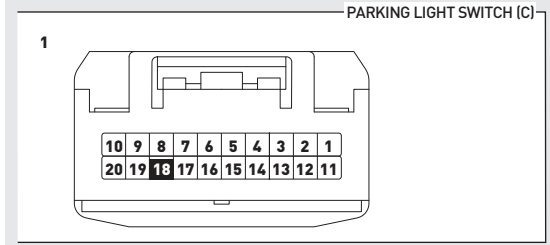
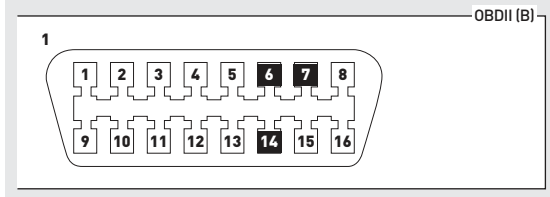
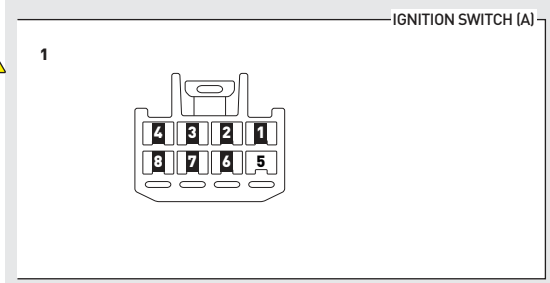
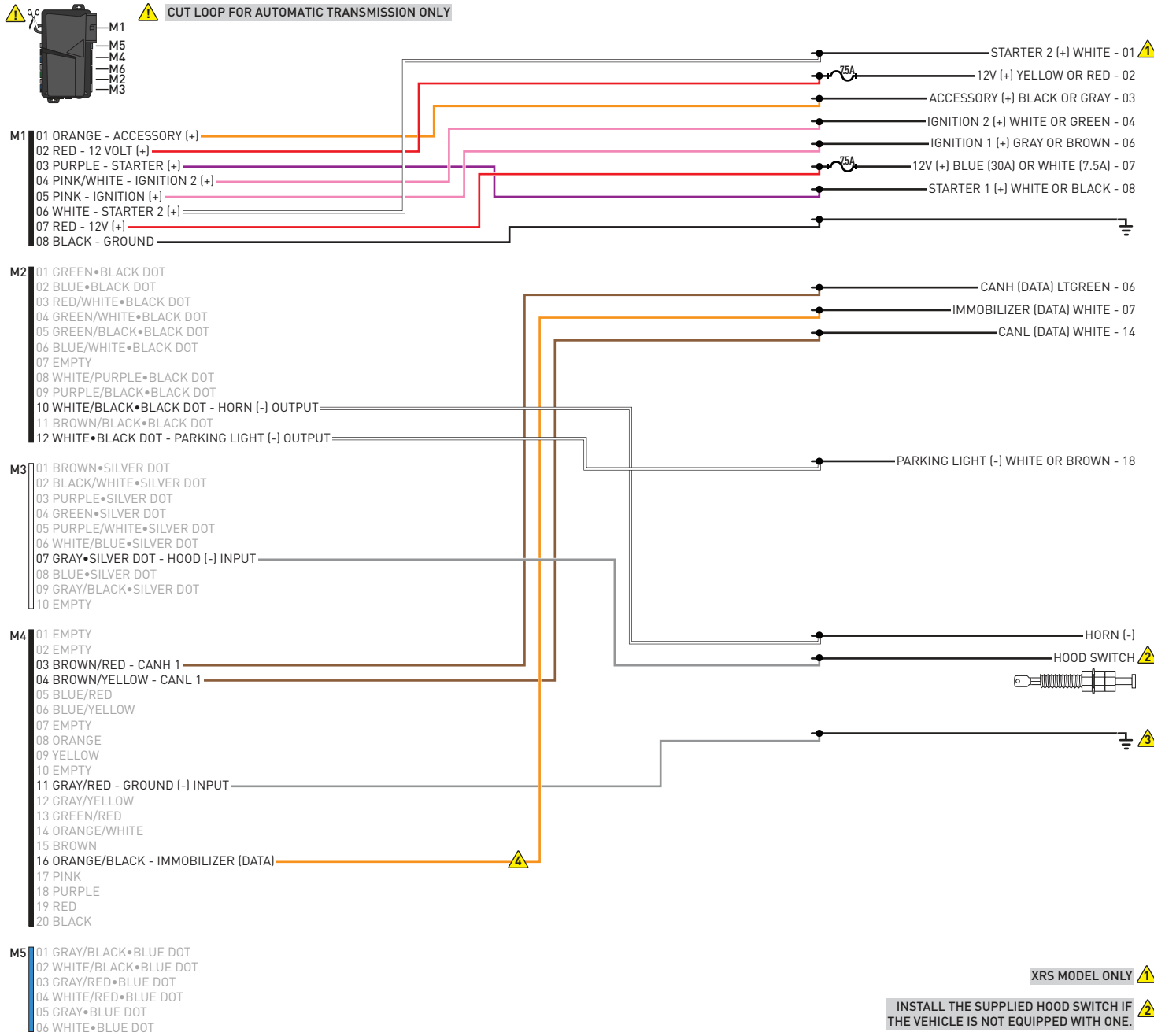

XRS MODEL ONLY ⚠

INSTALL THE SUPPLIED HOOD SWITCH IF THE VEHICLE IS NOT EQUIPPED WITH ONE. ⚠

WITHOUT OEM HOOD STATUS ONLY ⚠

CONNECT ORANGE/BLACK WIRE TO GROUND IF VEHICLE IS NOT EQUIPPED WITH IMMOBILIZER ⚠

01  Use the BLACK key only. DO NOT use the GRAY valet key.

02  Turn key to ON position.

03  Wait, LED 1 will turn solid GREEN for 2 seconds.

04  Turn key to OFF position.

05  START vehicle for 15 seconds.

06  Press and hold the brake pedal.

07  Press and release the module's programming button.

08  Release the brake pedal.

09  Wait, LED 2 will flash GREEN.

10  Module Programming Procedure completed.

>>



All vehicle doors must be closed and locked prior to remote start sequence.

01



Press unlock on OEM or aftermarket remote or request switch.

02



DO NOT PRESS BRAKE PEDAL. Set ignition to ON position. Wait 2 seconds for key validation.

03



Press and release BRAKE pedal.

04



Take over procedure completed.

>>



Failure to follow procedure will result in vehicle engine shutdown.

CHECKLIST - WITH AFTERMARKET KEYFOB

1	WARNING: Vehicle engine will start many times. Test in a well ventilated area.
2	Close all vehicle doors, hood and trunk.
3	Press the LOCK button once [1x] on the aftermarket keyfob.
	Question 1: Do the doors lock?
<input type="checkbox"/>	YES: Go to next step.
<input type="checkbox"/>	NO: Verify the remote programming, the RF connections and the wired door lock/unlock connections as illustrated in the wiring diagram, if applicable. Repeat the test and call technical support, if the problem persists.
4	Press the UNLOCK button once [1x] on the aftermarket keyfob.
	Question 2: Do the doors unlock?
<input type="checkbox"/>	YES: Go to next step.
<input type="checkbox"/>	NO: Verify the remote programming, the RF connections and the wired door lock/unlock connections as illustrated in the wiring diagram, if applicable. Repeat the test and call technical support, if the problem persists.
5	Press the TRUNK release button once [1x] on the aftermarket keyfob if supported.
	Question 3: Does the trunk or hatch open/unlock?
<input type="checkbox"/>	YES: Close trunk or hatch and go to next step.
<input type="checkbox"/>	NO: Verify the remote programming, the RF connections and the wired trunk/hatch connections as illustrated in the wiring diagram, if applicable. Repeat the test and call technical support, if the problem persists.
6	Press the AUX 1 button once [1x] on the aftermarket keyfob if supported.
	Question 4: Does the driver side sliding door open?
<input type="checkbox"/>	YES: Press the AUX 1 button once [1x] to close the driver sliding door and go to next step.
<input type="checkbox"/>	NO: Verify the remote programming and the RF connections. Repeat the test and call technical support, if the problem persists.
7	Press the AUX 2 button once [1x] on the aftermarket keyfob if supported.
	Question 5: Does the passenger side sliding door open?
<input type="checkbox"/>	YES: Press the AUX 2 button once [1x] to close the passenger sliding door and go to next step.
<input type="checkbox"/>	NO: Verify the remote programming and the RF connections. Repeat the test and call technical support, if the problem persists.
8	Press the START/STOP button once [1x] on the aftermarket keyfob to remote start vehicle.
	Question 6: Does the vehicle remote start?
<input type="checkbox"/>	YES: Go to next step.
<input type="checkbox"/>	NO: Verify the remote programming, the RF connections and check the remote start error codes. Repeat the test and call technical support, if the problem persists.

9	Press the START/STOP button once [1x] on the aftermarket keyfob to shut down vehicle.
	Question 7: Does the vehicle shut down?
<input type="checkbox"/>	YES: Go to next step.
<input type="checkbox"/>	NO: Repeat step. If problem persists, press the brake pedal once [1x] to shut down the vehicle and call technical support.
10	RAP and auto light shutdown test
	Question 8: Did the radio, interior controls and headlights turn off within 60 seconds after remote start shutdown?
<input type="checkbox"/>	YES: Go to next step.
<input type="checkbox"/>	NO: Verify the RAP SHUTDOWN connections as illustrated in the wiring diagram. Repeat the test and call technical support if the problem persists.
11	Open hood.
12	If not already installed, affix the mandatory orange warning sticker under the hood and proceed to next step.
13	Press the START/STOP button once [1x] on the aftermarket keyfob to remote start vehicle.
	Question 9: Does the vehicle remote start?
<input type="checkbox"/>	YES: The vehicle is not equipped with a factory hood pin. Install a mandatory aftermarket hood switch, then repeat the test.
<input type="checkbox"/>	NO: Go to next step.
14	Close hood.
15	Enter vehicle and close the doors.
16	Press the START/STOP button once [1x] on the aftermarket keyfob to remote start vehicle.
17	Wait for the vehicle to start.
18	Press brake pedal.
	Question 10: Does the vehicle shut down?
<input type="checkbox"/>	YES: Go to next step.
<input type="checkbox"/>	NO: The module does NOT detect the brake pedal signal. Press the START/STOP button once [1x] on the aftermarket keyfob to shut down vehicle, check connection as illustrated in the wiring diagram, if applicable, and call technical support.
19	Exit vehicle.
20	Installation checklist completed.

CHECKLIST - WITH OEM KEYFOB	
1	WARNING: Vehicle engine will start many times. Test in a well ventilated area.
2	Close all vehicle doors, hood and trunk.
3	Press LOCK button three times [3x] rapidly on the OEM keyfob to remote start vehicle.
	Question 1: Does the vehicle remote start?
<input type="checkbox"/>	YES: Go to next step.
<input type="checkbox"/>	NO: The module doesn't detect OEM remote lock button from the vehicle communication network. Check all connections, repeat the test and call technical support, if the problem persists.
4	Press LOCK button three times [3x] rapidly on the OEM keyfob to shut down vehicle.
	Question 2: Does the vehicle shut down?
<input type="checkbox"/>	YES: Go to next step.
<input type="checkbox"/>	NO: Repeat step. If the problem persists, press on the brake pedal once [1x] to shut down the vehicle and call technical support.
5	RAP Shutdown test
	Question 3: Did the radio, interior controls, and headlights turn off within 60 seconds after remote start shutdown?
<input type="checkbox"/>	YES: Go to next step.
<input type="checkbox"/>	NO: Verify the RAP SHUTDOWN connections as illustrated in the wiring diagram. Repeat the test and call technical support, if the problem persists.
6	Open hood.
7	If not already installed, affix the mandatory orange warning sticker under the hood and proceed to next step.
8	Press LOCK button three times [3x] rapidly on the OEM keyfob to remote start vehicle.
	Question 4: Does the vehicle remote start?
<input type="checkbox"/>	YES: The vehicle is not equipped with a factory hood pin. Install a mandatory aftermarket hood switch, then repeat the test.
<input type="checkbox"/>	NO: Go to next step.
9	Close hood.
10	Enter vehicle and close the doors.
11	Press LOCK button three times [3x] rapidly on the OEM keyfob to remote start vehicle.
12	Wait for the vehicle to start.
13	Press brake pedal.
	Question 5: Does the vehicle shut down?
<input type="checkbox"/>	YES: Go to next step.
<input type="checkbox"/>	NO: The module does NOT detect the brake pedal signal. Press LOCK button three times [3x] rapidly on the OEM keyfob to shut down, check the brake connection as illustrated in the wiring diagram, if applicable, and call technical support.
14	Exit vehicle.
15	Installation checklist completed.

COMPUSTAR®

INSTALL GUIDE

2010-2014 TOYOTA FJ CRUISER 80-BIT STD KEY AT

DOCUMENT NUMBER

REVISION DATE

20180926

FIRMWARE

COM-RSA-TL5-[RS1B-DC3]

HARDWARE

RS1B-DC3

ACCESSORIES

ATTENTION: TO COMPLETE THIS INSTALLATION SOME ACCESSORIES MAY BE REQUIRED. VISIT OUR WEBSITE TO SEE ALL THE REQUIRED ACCESSORIES FOR YOUR VEHICLE.

TERMS OF USE

Automotive Data Solutions Inc. ("ADS") products are strictly intended for installation by Certified Technicians who are employed by a registered business specialized in the installation of automotive aftermarket electronics products. Prior to beginning installation of an ADS product in a vehicle, it is the Certified Technician's responsibility to review the most current Product Guide, Install Guide and vehicle-specific notes available in Weblink®. ADS is not responsible for any damages whatsoever, including but not limited to any consequential damages, incidental damages, damages for loss of time, loss of earnings, loss of profit, commercial loss, loss of economic opportunity and the like that may or may not have resulted from the use, misuse, improper installation or operation of its products. ADS reserves itself the right to suspend any Weblink® account without notice and decline to offer technical support to non-Certified Technicians, non-compliant Certified Technicians or end users.



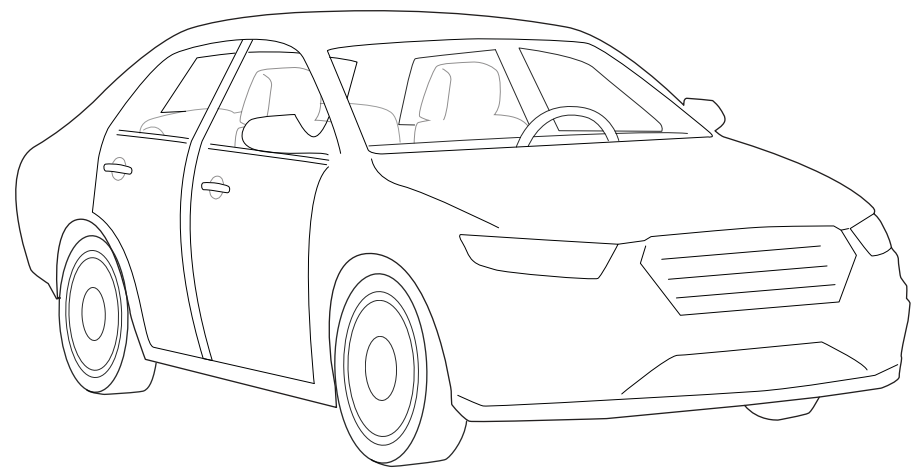
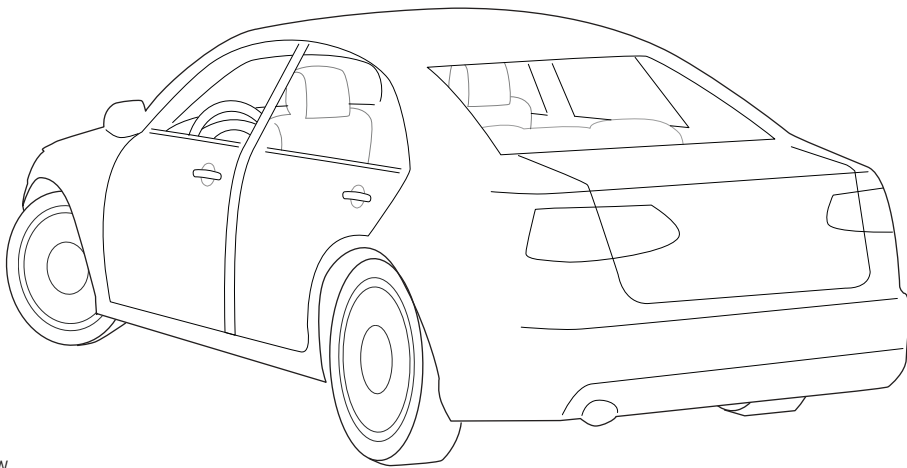
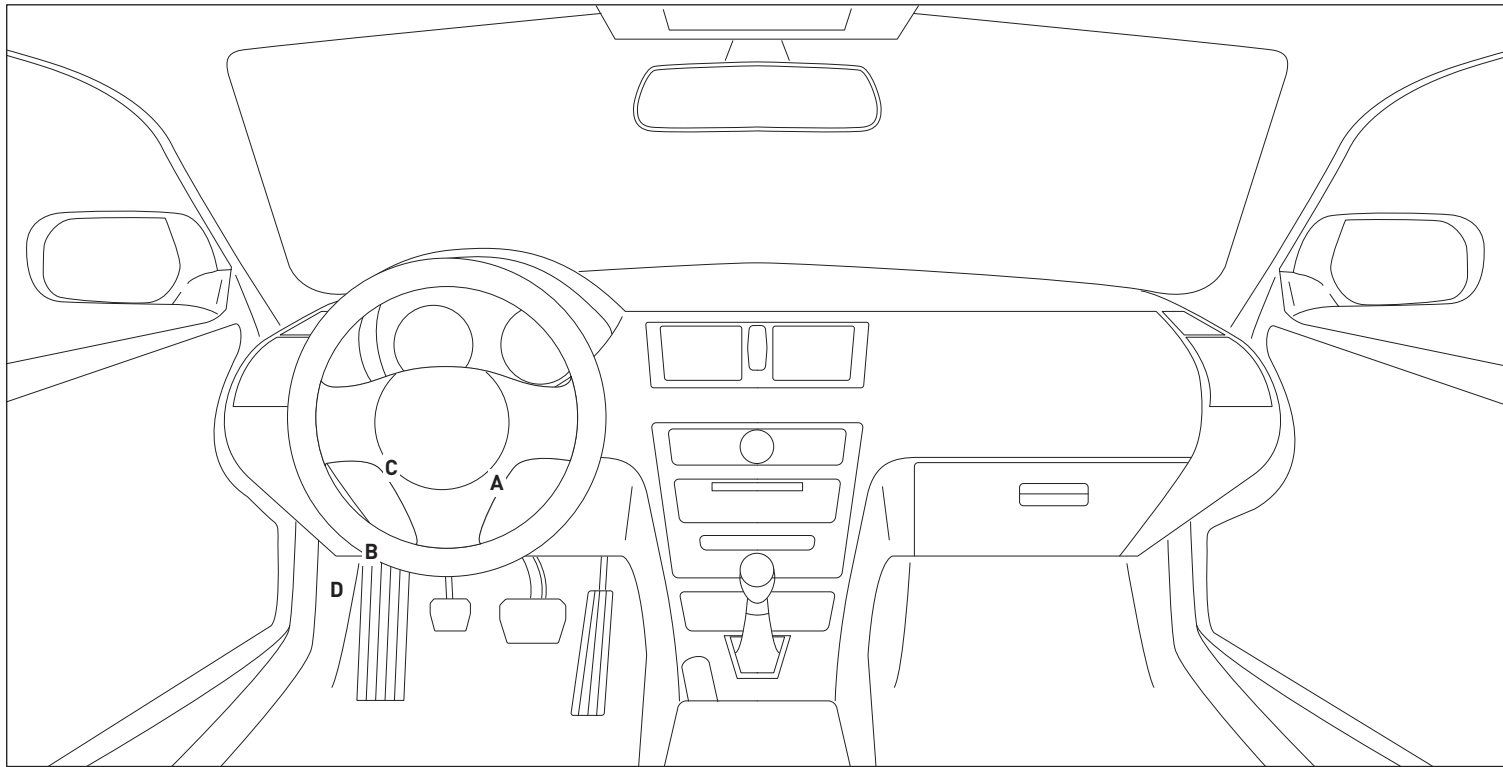

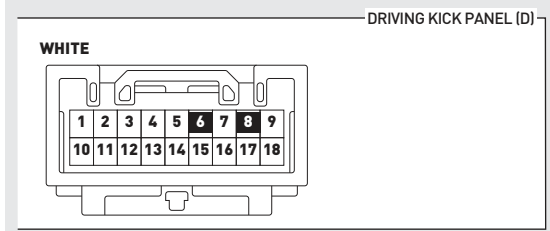
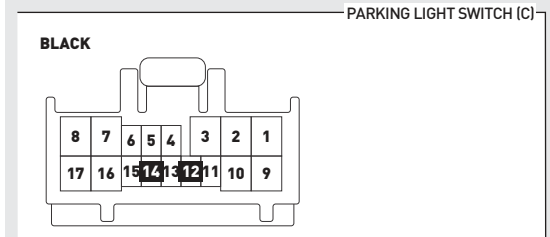
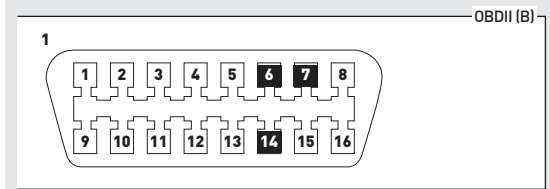
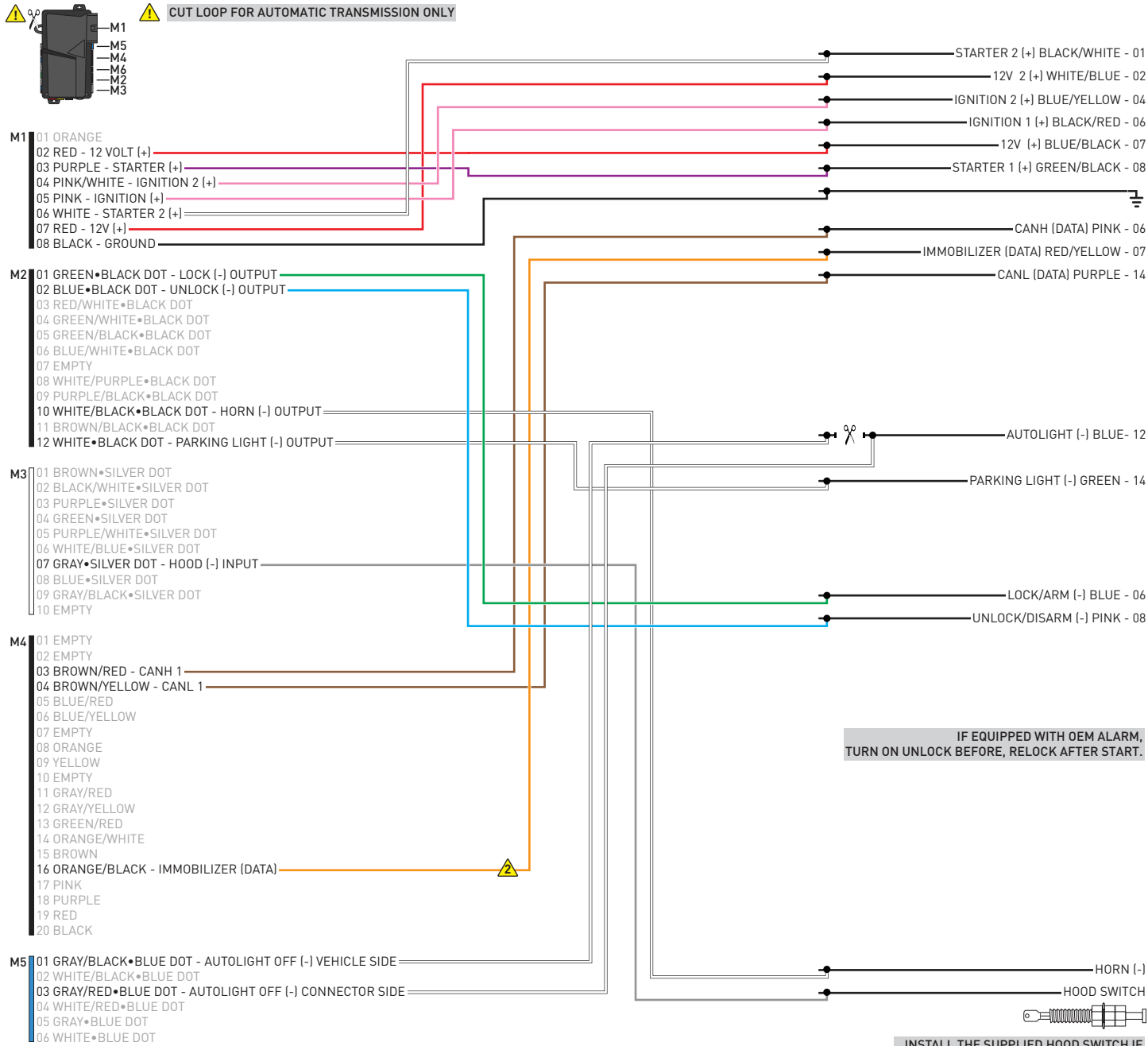



**IF EQUIPPED WITH OEM ALARM,
TURN ON UNLOCK BEFORE, RELOCK AFTER START.**

**INSTALL THE SUPPLIED HOOD SWITCH IF
THE VEHICLE IS NOT EQUIPPED WITH ONE.**

**CONNECT ORANGE/BLACK WIRE TO GROUND IF
VEHICLE IS NOT EQUIPPED WITH IMMOBILIZER**

01  Use the BLACK key only. DO NOT use the GRAY valet key.

02  Turn key to ON position.

03  Wait, LED 1 will turn solid GREEN for 2 seconds.

04  Turn key to OFF position.

05  START vehicle for 15 seconds.

06  Press and hold the brake pedal.

07  Press and release the module's programming button.

08  Release the brake pedal.

09  Wait, LED 2 will flash GREEN.

10  Module Programming Procedure completed.

>>



All vehicle doors must be closed and locked prior to remote start sequence.

01



Press unlock on OEM or aftermarket remote or request switch.

02



DO NOT PRESS BRAKE PEDAL. Set ignition to ON position. Wait 2 seconds for key validation.

03



Press and release BRAKE pedal.

04



Take over procedure completed.

>>



Failure to follow procedure will result in vehicle engine shutdown.

CHECKLIST - WITH AFTERMARKET KEYFOB

1	WARNING: Vehicle engine will start many times. Test in a well ventilated area.
2	Close all vehicle doors, hood and trunk.
3	Press the LOCK button once [1x] on the aftermarket keyfob.
	Question 1: Do the doors lock?
<input type="checkbox"/>	YES: Go to next step.
<input type="checkbox"/>	NO: Verify the remote programming, the RF connections and the wired door lock/unlock connections as illustrated in the wiring diagram, if applicable. Repeat the test and call technical support, if the problem persists.
4	Press the UNLOCK button once [1x] on the aftermarket keyfob.
	Question 2: Do the doors unlock?
<input type="checkbox"/>	YES: Go to next step.
<input type="checkbox"/>	NO: Verify the remote programming, the RF connections and the wired door lock/unlock connections as illustrated in the wiring diagram, if applicable. Repeat the test and call technical support, if the problem persists.
5	Press the TRUNK release button once [1x] on the aftermarket keyfob if supported.
	Question 3: Does the trunk or hatch open/unlock?
<input type="checkbox"/>	YES: Close trunk or hatch and go to next step.
<input type="checkbox"/>	NO: Verify the remote programming, the RF connections and the wired trunk/hatch connections as illustrated in the wiring diagram, if applicable. Repeat the test and call technical support, if the problem persists.
6	Press the AUX 1 button once [1x] on the aftermarket keyfob if supported.
	Question 4: Does the driver side sliding door open?
<input type="checkbox"/>	YES: Press the AUX 1 button once [1x] to close the driver sliding door and go to next step.
<input type="checkbox"/>	NO: Verify the remote programming and the RF connections. Repeat the test and call technical support, if the problem persists.
7	Press the AUX 2 button once [1x] on the aftermarket keyfob if supported.
	Question 5: Does the passenger side sliding door open?
<input type="checkbox"/>	YES: Press the AUX 2 button once [1x] to close the passenger sliding door and go to next step.
<input type="checkbox"/>	NO: Verify the remote programming and the RF connections. Repeat the test and call technical support, if the problem persists.
8	Press the START/STOP button once [1x] on the aftermarket keyfob to remote start vehicle.
	Question 6: Does the vehicle remote start?
<input type="checkbox"/>	YES: Go to next step.
<input type="checkbox"/>	NO: Verify the remote programming, the RF connections and check the remote start error codes. Repeat the test and call technical support, if the problem persists.

9	Press the START/STOP button once [1x] on the aftermarket keyfob to shut down vehicle.
	Question 7: Does the vehicle shut down?
<input type="checkbox"/>	YES: Go to next step.
<input type="checkbox"/>	NO: Repeat step. If problem persists, press the brake pedal once [1x] to shut down the vehicle and call technical support.
10	RAP and auto light shutdown test
	Question 8: Did the radio, interior controls and headlights turn off within 60 seconds after remote start shutdown?
<input type="checkbox"/>	YES: Go to next step.
<input type="checkbox"/>	NO: Verify the RAP SHUTDOWN connections as illustrated in the wiring diagram. Repeat the test and call technical support if the problem persists.
11	Open hood.
12	If not already installed, affix the mandatory orange warning sticker under the hood and proceed to next step.
13	Press the START/STOP button once [1x] on the aftermarket keyfob to remote start vehicle.
	Question 9: Does the vehicle remote start?
<input type="checkbox"/>	YES: The vehicle is not equipped with a factory hood pin. Install a mandatory aftermarket hood switch, then repeat the test.
<input type="checkbox"/>	NO: Go to next step.
14	Close hood.
15	Enter vehicle and close the doors.
16	Press the START/STOP button once [1x] on the aftermarket keyfob to remote start vehicle.
17	Wait for the vehicle to start.
18	Press brake pedal.
	Question 10: Does the vehicle shut down?
<input type="checkbox"/>	YES: Go to next step.
<input type="checkbox"/>	NO: The module does NOT detect the brake pedal signal. Press the START/STOP button once [1x] on the aftermarket keyfob to shut down vehicle, check connection as illustrated in the wiring diagram, if applicable, and call technical support.
19	Exit vehicle.
20	Installation checklist completed.

CHECKLIST - WITH OEM KEYFOB	
1	WARNING: Vehicle engine will start many times. Test in a well ventilated area.
2	Close all vehicle doors, hood and trunk.
3	Press LOCK button three times [3x] rapidly on the OEM keyfob to remote start vehicle.
	Question 1: Does the vehicle remote start?
<input type="checkbox"/>	YES: Go to next step.
<input type="checkbox"/>	NO: The module doesn't detect OEM remote lock button from the vehicle communication network. Check all connections, repeat the test and call technical support, if the problem persists.
4	Press LOCK button three times [3x] rapidly on the OEM keyfob to shut down vehicle.
	Question 2: Does the vehicle shut down?
<input type="checkbox"/>	YES: Go to next step.
<input type="checkbox"/>	NO: Repeat step. If the problem persists, press on the brake pedal once [1x] to shut down the vehicle and call technical support.
5	RAP Shutdown test
	Question 3: Did the radio, interior controls, and headlights turn off within 60 seconds after remote start shutdown?
<input type="checkbox"/>	YES: Go to next step.
<input type="checkbox"/>	NO: Verify the RAP SHUTDOWN connections as illustrated in the wiring diagram. Repeat the test and call technical support, if the problem persists.
6	Open hood.
7	If not already installed, affix the mandatory orange warning sticker under the hood and proceed to next step.
8	Press LOCK button three times [3x] rapidly on the OEM keyfob to remote start vehicle.
	Question 4: Does the vehicle remote start?
<input type="checkbox"/>	YES: The vehicle is not equipped with a factory hood pin. Install a mandatory aftermarket hood switch, then repeat the test.
<input type="checkbox"/>	NO: Go to next step.
9	Close hood.
10	Enter vehicle and close the doors.
11	Press LOCK button three times [3x] rapidly on the OEM keyfob to remote start vehicle.
12	Wait for the vehicle to start.
13	Press brake pedal.
	Question 5: Does the vehicle shut down?
<input type="checkbox"/>	YES: Go to next step.
<input type="checkbox"/>	NO: The module does NOT detect the brake pedal signal. Press LOCK button three times [3x] rapidly on the OEM keyfob to shut down, check the brake connection as illustrated in the wiring diagram, if applicable, and call technical support.
14	Exit vehicle.
15	Installation checklist completed.

COMPUSTAR®

INSTALL GUIDE

2012-2013 TOYOTA HIGHLANDER HYBRID 80-BIT STD KEY AT

DOCUMENT NUMBER

REVISION DATE

20180926

FIRMWARE

COM-RSA-TL5-[RS1B-DC3]

HARDWARE

RS1B-DC3

ACCESSORIES

ATTENTION: TO COMPLETE THIS INSTALLATION SOME ACCESSORIES MAY BE REQUIRED. VISIT OUR WEBSITE TO SEE ALL THE REQUIRED ACCESSORIES FOR YOUR VEHICLE.

TERMS OF USE

Automotive Data Solutions Inc. ("ADS") products are strictly intended for installation by Certified Technicians who are employed by a registered business specialized in the installation of automotive aftermarket electronics products. Prior to beginning installation of an ADS product in a vehicle, it is the Certified Technician's responsibility to review the most current Product Guide, Install Guide and vehicle-specific notes available in Weblink®. ADS is not responsible for any damages whatsoever, including but not limited to any consequential damages, incidental damages, damages for loss of time, loss of earnings, loss of profit, commercial loss, loss of economic opportunity and the like that may or may not have resulted from the use, misuse, improper installation or operation of its products. ADS reserves itself the right to suspend any Weblink® account without notice and decline to offer technical support to non-Certified Technicians, non-compliant Certified Technicians or end users.



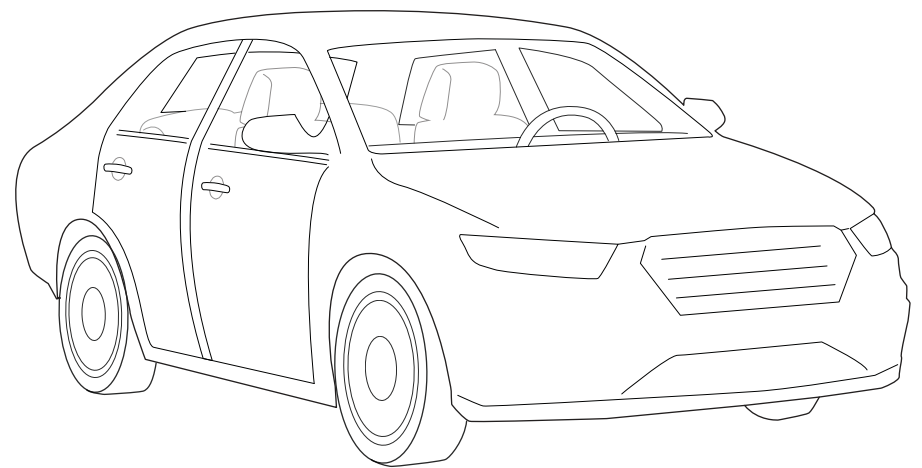
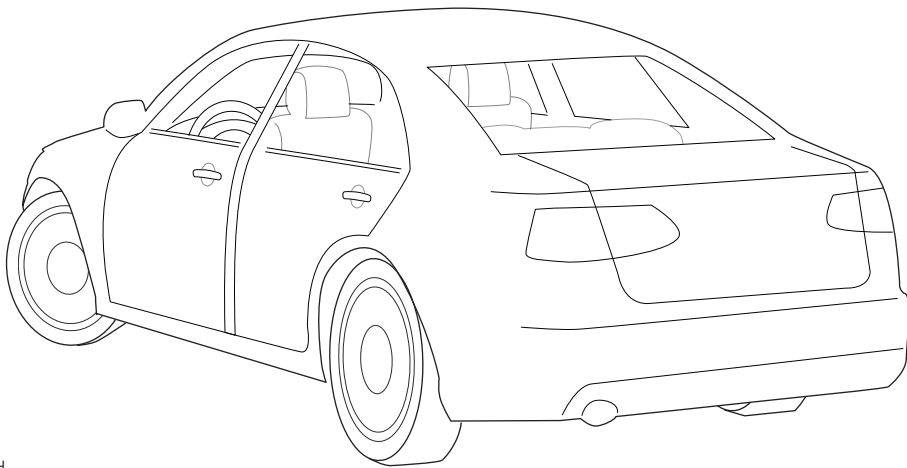
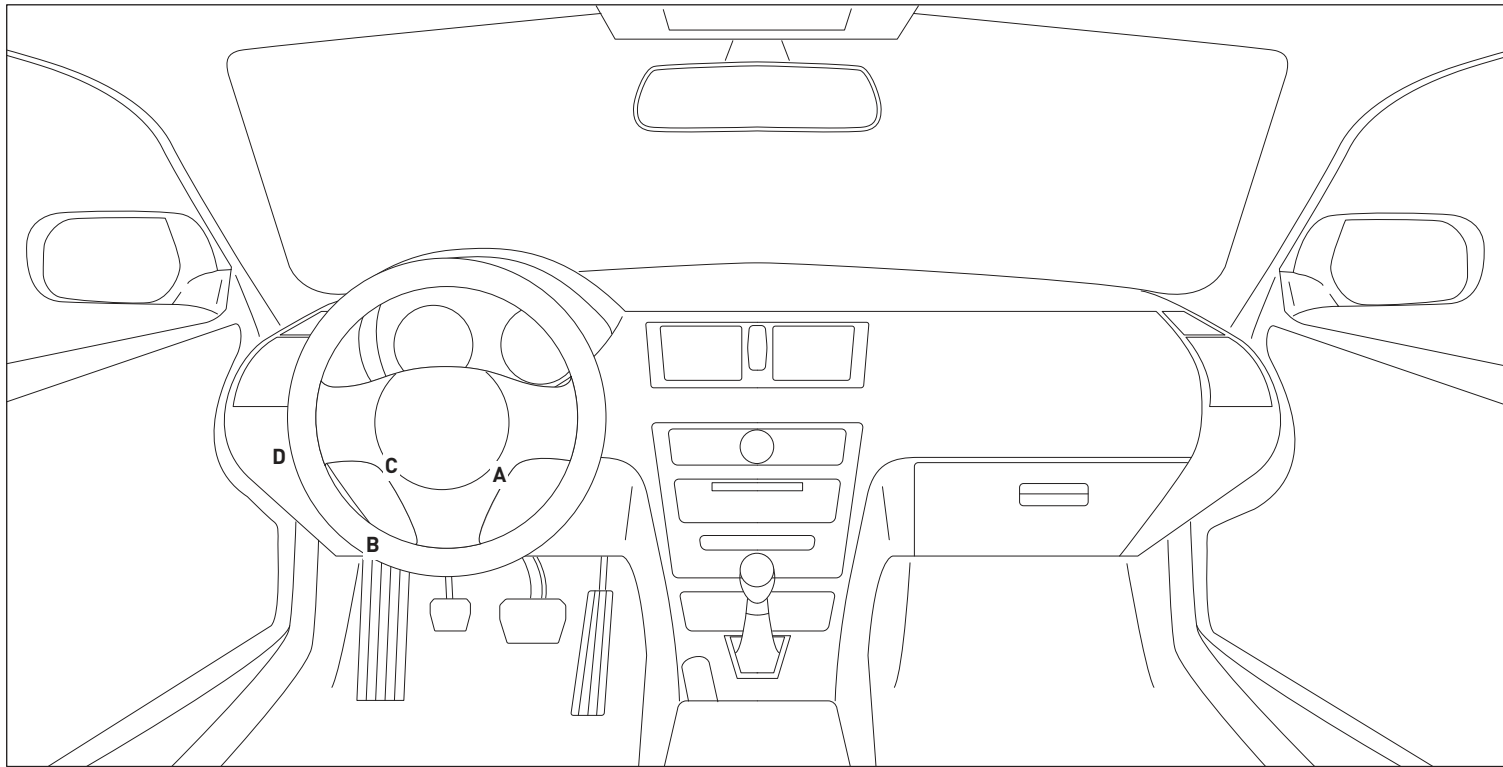

- CUT LOOP FOR AUTOMATIC TRANSMISSION ONLY
- SOME PARTS OF THE T-HARNESS (MS4-C, MS2-A, VS3/VS4 AND JS8) ARE NOT USED IN THIS INSTALL DO NOT CONNECT THEM.
- JS7 IS NOT USED IF THE VEHICLE IS EQUIPPED WITH AN IMMOBILIZER

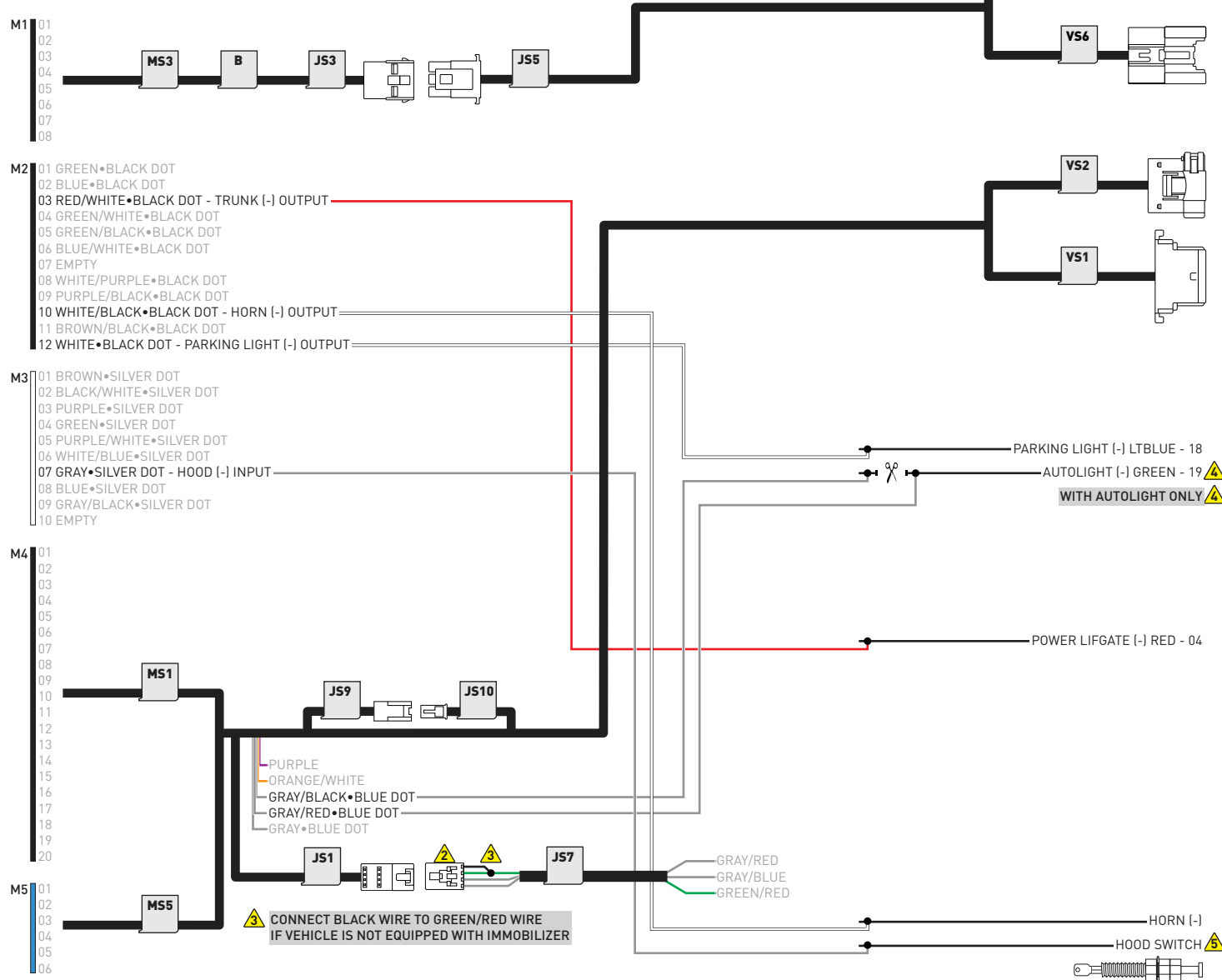

CONNECT BLACK WIRE TO GREEN/RED WIRE IF VEHICLE IS NOT EQUIPPED WITH IMMOBILIZER

IF NOT EQUIPPED WITH AN OEM HOOD PIN:
 - INSTALL THE SUPPLIED HOOD SWITCH.
 - CHANGE REMOTE STARTER INPUT CONFIGURATION (MENU #7) "4- HOOD INPUT SOURCE" TO "1- ANALOG".

IGNITION SWITCH (A)

1: IGNITION CONNECTOR

1: IGNITION HARNESS

OBDII (B)

1: OBDII CONNECTOR

1: OBDII HOLDER

PARKING LIGHT SWITCH (C)

1: BLACK

POWER LIFGATE SWITCH (D)

1: BLACK

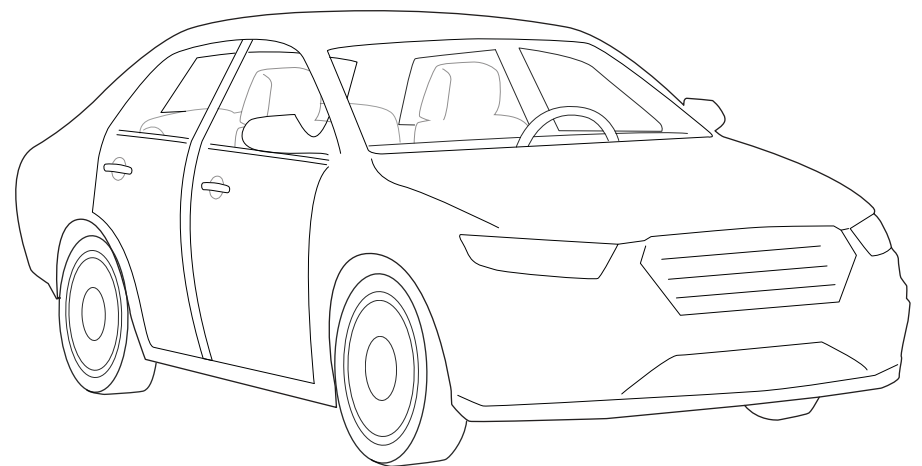
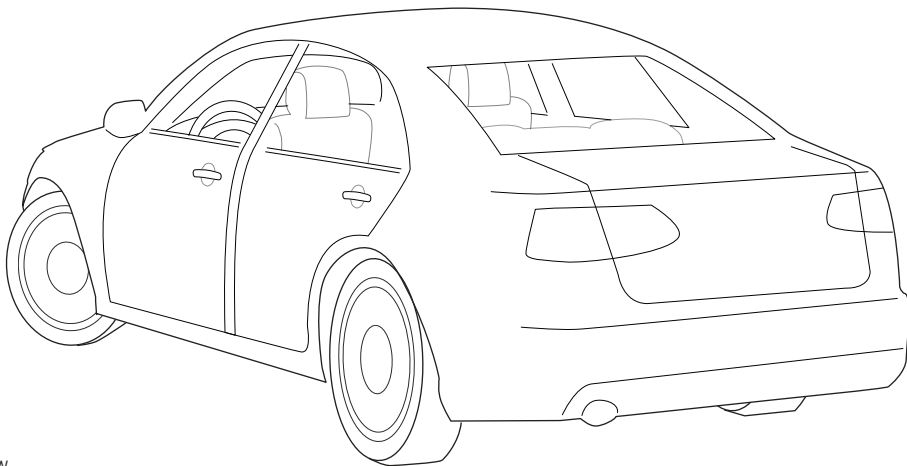
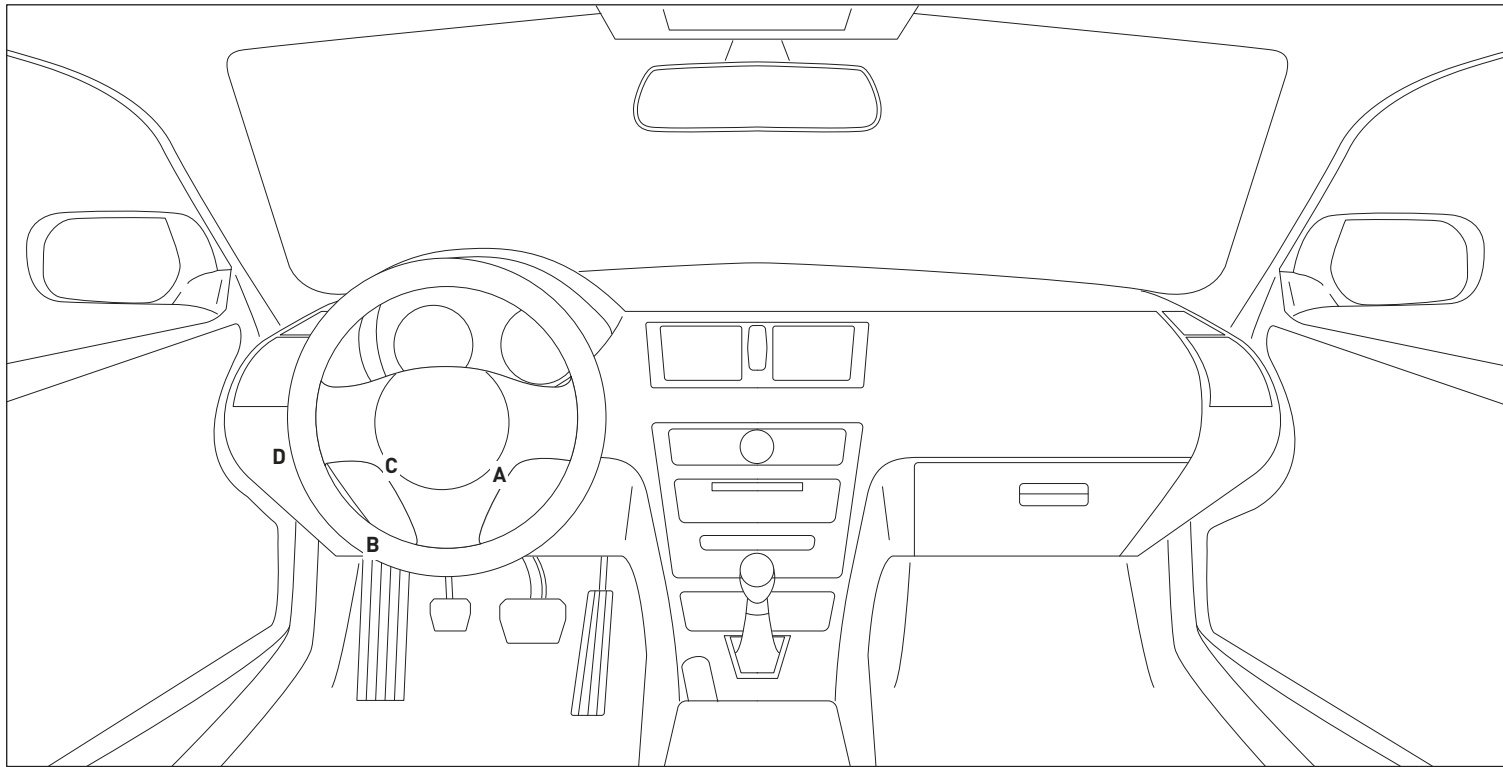

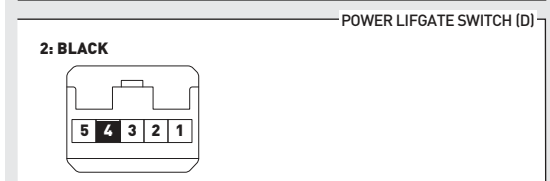
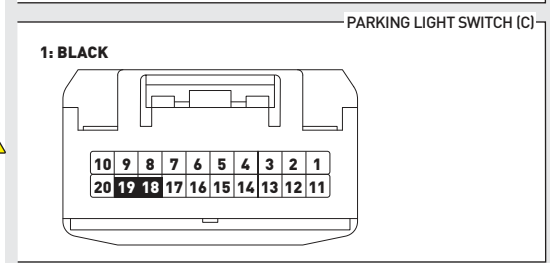
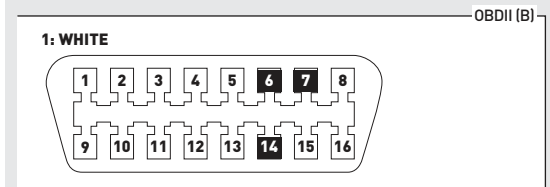
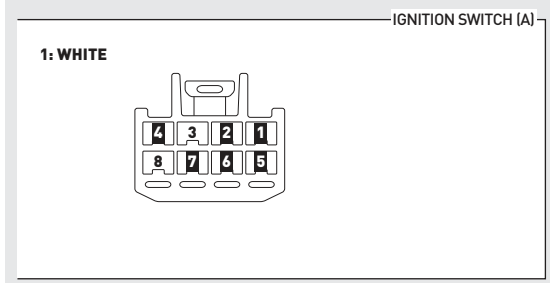
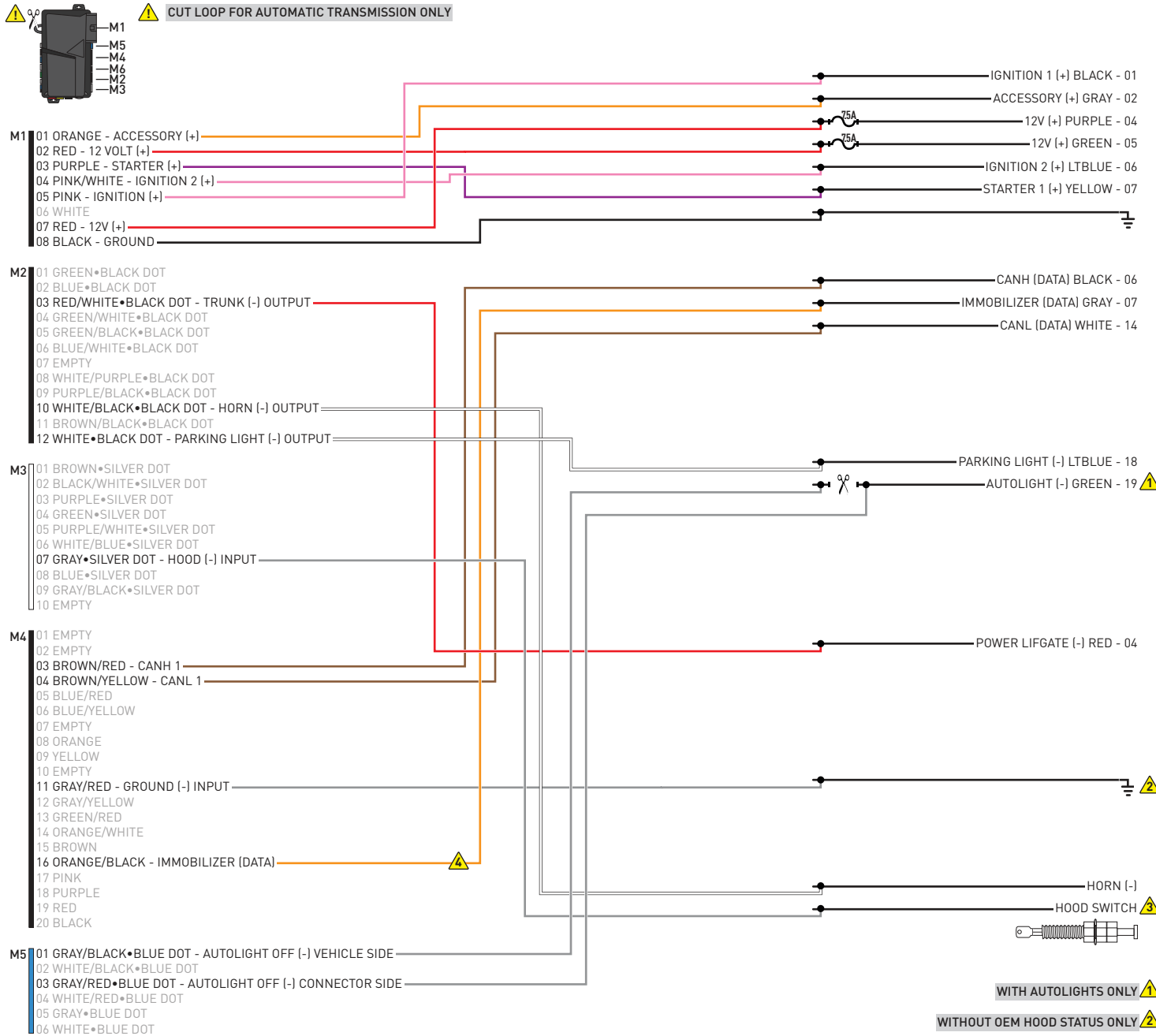

WITH AUTOLIGHTS ONLY ⚠

WITHOUT OEM HOOD STATUS ONLY ⚠

INSTALL THE SUPPLIED HOOD SWITCH IF THE VEHICLE IS NOT EQUIPPED WITH ONE. ⚠

CONNECT ORANGE/BLACK WIRE TO GROUND IF VEHICLE IS NOT EQUIPPED WITH IMMOBILIZER ⚠

01  Use the BLACK key only. DO NOT use the GRAY valet key.

02  Turn key to ON position.

03  Wait, LED 1 will turn solid GREEN for 2 seconds.

04  Turn key to OFF position.

05  START vehicle for 15 seconds.

06  Press and hold the brake pedal.

07  Press and release the module's programming button.

08  Release the brake pedal.

09  Wait, LED 2 will flash GREEN.

10  Module Programming Procedure completed.

>>



All vehicle doors must be closed and locked prior to remote start sequence.

01



Press unlock on OEM or aftermarket remote or request switch.

02



DO NOT PRESS BRAKE PEDAL. Set ignition to ON position. Wait 2 seconds for key validation.

03



Press and release BRAKE pedal.

04



Take over procedure completed.

>>



Failure to follow procedure will result in vehicle engine shutdown.

CHECKLIST - WITH AFTERMARKET KEYFOB	
1	WARNING: Vehicle engine will start many times. Test in a well ventilated area.
2	Close all vehicle doors, hood and trunk.
3	Press the LOCK button once [1x] on the aftermarket keyfob.
	Question 1: Do the doors lock?
<input type="checkbox"/>	YES: Go to next step.
<input type="checkbox"/>	NO: Verify the remote programming, the RF connections and the wired door lock/unlock connections as illustrated in the wiring diagram, if applicable. Repeat the test and call technical support, if the problem persists.
4	Press the UNLOCK button once [1x] on the aftermarket keyfob.
	Question 2: Do the doors unlock?
<input type="checkbox"/>	YES: Go to next step.
<input type="checkbox"/>	NO: Verify the remote programming, the RF connections and the wired door lock/unlock connections as illustrated in the wiring diagram, if applicable. Repeat the test and call technical support, if the problem persists.
5	Press the TRUNK release button once [1x] on the aftermarket keyfob if supported.
	Question 3: Does the trunk or hatch open/unlock?
<input type="checkbox"/>	YES: Close trunk or hatch and go to next step.
<input type="checkbox"/>	NO: Verify the remote programming, the RF connections and the wired trunk/hatch connections as illustrated in the wiring diagram, if applicable. Repeat the test and call technical support, if the problem persists.
6	Press the AUX 1 button once [1x] on the aftermarket keyfob if supported.
	Question 4: Does the driver side sliding door open?
<input type="checkbox"/>	YES: Press the AUX 1 button once [1x] to close the driver sliding door and go to next step.
<input type="checkbox"/>	NO: Verify the remote programming and the RF connections. Repeat the test and call technical support, if the problem persists.
7	Press the AUX 2 button once [1x] on the aftermarket keyfob if supported.
	Question 5: Does the passenger side sliding door open?
<input type="checkbox"/>	YES: Press the AUX 2 button once [1x] to close the passenger sliding door and go to next step.
<input type="checkbox"/>	NO: Verify the remote programming and the RF connections. Repeat the test and call technical support, if the problem persists.
8	Press the START/STOP button once [1x] on the aftermarket keyfob to remote start vehicle.
	Question 6: Does the vehicle remote start?
<input type="checkbox"/>	YES: Go to next step.
<input type="checkbox"/>	NO: Verify the remote programming, the RF connections and check the remote start error codes. Repeat the test and call technical support, if the problem persists.
9	Press the START/STOP button once [1x] on the aftermarket keyfob to shut down vehicle.
	Question 7: Does the vehicle shut down?
<input type="checkbox"/>	YES: Go to next step.
<input type="checkbox"/>	NO: Repeat step. If problem persists, press the brake pedal once [1x] to shut down the vehicle and call technical support.
10	RAP and auto light shutdown test
	Question 8: Did the radio, interior controls and headlights turn off within 60 seconds after remote start shutdown?
<input type="checkbox"/>	YES: Go to next step.
<input type="checkbox"/>	NO: Verify the RAP SHUTDOWN connections as illustrated in the wiring diagram. Repeat the test and call technical support if the problem persists.
11	Open hood.
12	If not already installed, affix the mandatory orange warning sticker under the hood and proceed to next step.
13	Press the START/STOP button once [1x] on the aftermarket keyfob to remote start vehicle.
	Question 9: Does the vehicle remote start?
<input type="checkbox"/>	YES: The vehicle is not equipped with a factory hood pin. Install a mandatory aftermarket hood switch, then repeat the test.
<input type="checkbox"/>	NO: Go to next step.
14	Close hood.
15	Enter vehicle and close the doors.
16	Press the START/STOP button once [1x] on the aftermarket keyfob to remote start vehicle.
17	Wait for the vehicle to start.
18	Press brake pedal.
	Question 10: Does the vehicle shut down?
<input type="checkbox"/>	YES: Go to next step.
<input type="checkbox"/>	NO: The module does NOT detect the brake pedal signal. Press the START/STOP button once [1x] on the aftermarket keyfob to shut down vehicle, check connection as illustrated in the wiring diagram, if applicable, and call technical support.
19	Exit vehicle.
20	Installation checklist completed.

CHECKLIST - WITH OEM KEYFOB	
1	WARNING: Vehicle engine will start many times. Test in a well ventilated area.
2	Close all vehicle doors, hood and trunk.
3	Press LOCK button three times [3x] rapidly on the OEM keyfob to remote start vehicle.
	Question 1: Does the vehicle remote start?
<input type="checkbox"/>	YES: Go to next step.
<input type="checkbox"/>	NO: The module doesn't detect OEM remote lock button from the vehicle communication network. Check all connections, repeat the test and call technical support, if the problem persists.
4	Press LOCK button three times [3x] rapidly on the OEM keyfob to shut down vehicle.
	Question 2: Does the vehicle shut down?
<input type="checkbox"/>	YES: Go to next step.
<input type="checkbox"/>	NO: Repeat step. If the problem persists, press on the brake pedal once [1x] to shut down the vehicle and call technical support.
5	RAP Shutdown test
	Question 3: Did the radio, interior controls, and headlights turn off within 60 seconds after remote start shutdown?
<input type="checkbox"/>	YES: Go to next step.
<input type="checkbox"/>	NO: Verify the RAP SHUTDOWN connections as illustrated in the wiring diagram. Repeat the test and call technical support, if the problem persists.
6	Open hood.
7	If not already installed, affix the mandatory orange warning sticker under the hood and proceed to next step.
8	Press LOCK button three times [3x] rapidly on the OEM keyfob to remote start vehicle.
	Question 4: Does the vehicle remote start?
<input type="checkbox"/>	YES: The vehicle is not equipped with a factory hood pin. Install a mandatory aftermarket hood switch, then repeat the test.
<input type="checkbox"/>	NO: Go to next step.
9	Close hood.
10	Enter vehicle and close the doors.
11	Press LOCK button three times [3x] rapidly on the OEM keyfob to remote start vehicle.
12	Wait for the vehicle to start.
13	Press brake pedal.
	Question 5: Does the vehicle shut down?
<input type="checkbox"/>	YES: Go to next step.
<input type="checkbox"/>	NO: The module does NOT detect the brake pedal signal. Press LOCK button three times [3x] rapidly on the OEM keyfob to shut down, check the brake connection as illustrated in the wiring diagram, if applicable, and call technical support.
14	Exit vehicle.
15	Installation checklist completed.



INSTALL GUIDE

2011-2013 TOYOTA HIGHLANDER 80-BIT STD KEY AT

DOCUMENT NUMBER

REVISION DATE

20180926

FIRMWARE

COM-RSA-TL5-[RS1B-DC3]

HARDWARE

RS1B-DC3

ACCESSORIES

ATTENTION: TO COMPLETE THIS INSTALLATION SOME ACCESSORIES MAY BE REQUIRED.
VISIT OUR WEBSITE TO SEE ALL THE REQUIRED ACCESSORIES FOR YOUR VEHICLE.

TERMS OF USE

Automotive Data Solutions Inc. ("ADS") products are strictly intended for installation by Certified Technicians who are employed by a registered business specialized in the installation of automotive aftermarket electronics products. Prior to beginning installation of an ADS product in a vehicle, it is the Certified Technician's responsibility to review the most current Product Guide, Install Guide and vehicle-specific notes available in Weblink®. ADS is not responsible for any damages whatsoever, including but not limited to any consequential damages, incidental damages, damages for loss of time, loss of earnings, loss of profit, commercial loss, loss of economic opportunity and the like that may or may not have resulted from the use, misuse, improper installation or operation of its products. ADS reserves itself the right to suspend any Weblink® account without notice and decline to offer technical support to non-Certified Technicians, non-compliant Certified Technicians or end users.



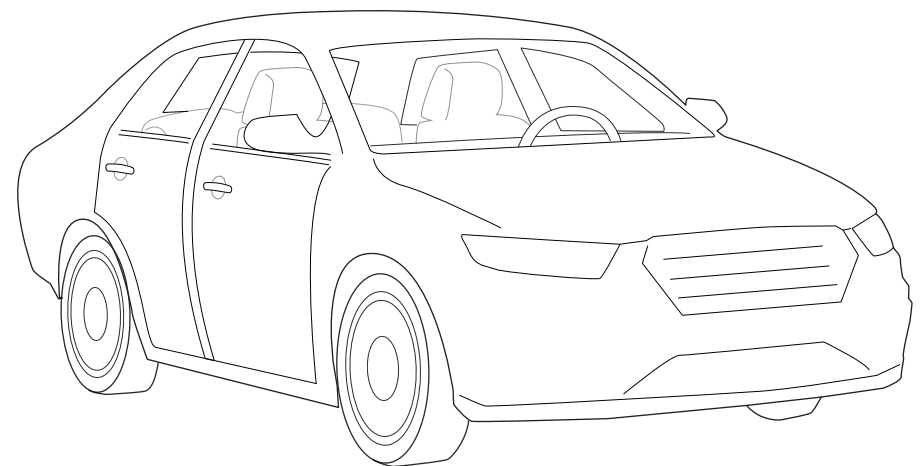
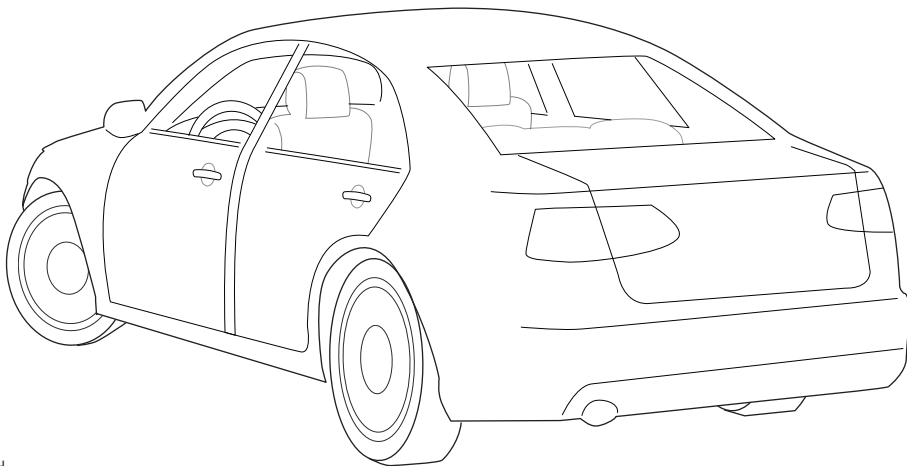
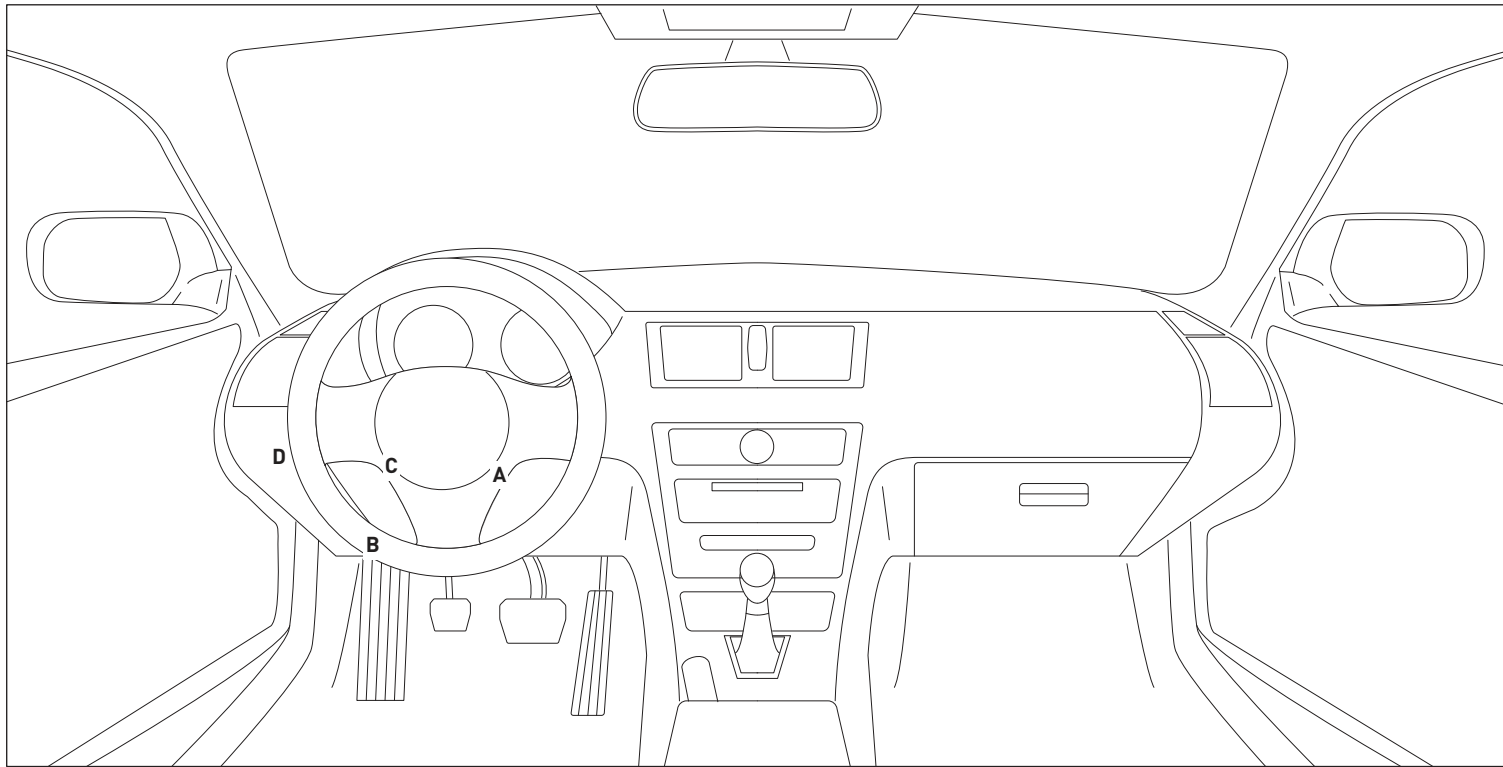

- CUT LOOP FOR AUTOMATIC TRANSMISSION ONLY
- SOME PARTS OF THE T-HARNESS (MS4-C, MS2-A, VS3/VS4 AND JS8) ARE NOT USED IN THIS INSTALL DO NOT CONNECT THEM.
- JS7 IS NOT USED IF THE VEHICLE IS EQUIPPED WITH AN IMMOBILIZER

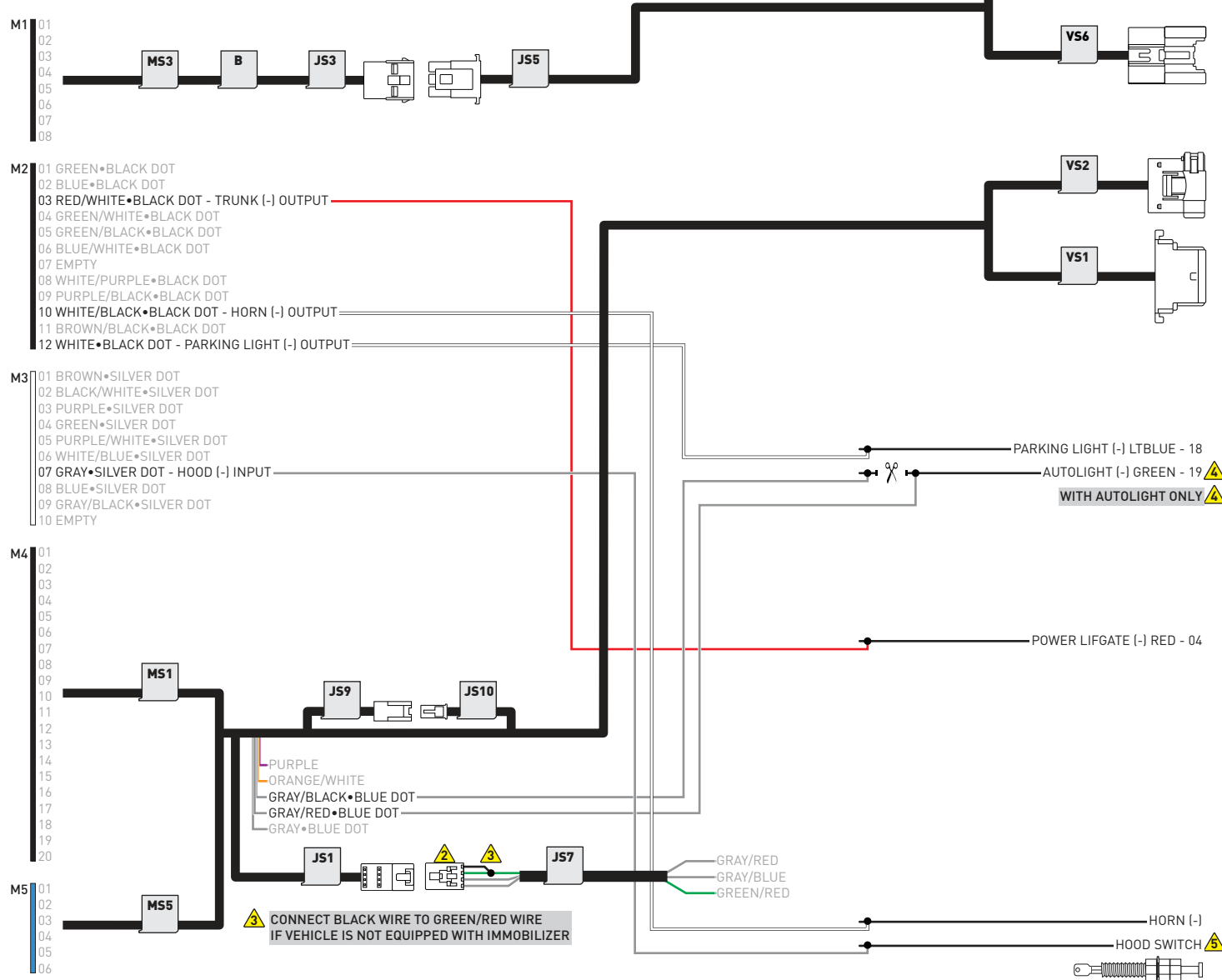

CONNECT BLACK WIRE TO GREEN/RED WIRE IF VEHICLE IS NOT EQUIPPED WITH IMMOBILIZER

IF NOT EQUIPPED WITH AN OEM HOOD PIN:
 - INSTALL THE SUPPLIED HOOD SWITCH.
 - CHANGE REMOTE STARTER INPUT CONFIGURATION (MENU #7) "4- HOOD INPUT SOURCE" TO "1- ANALOG".

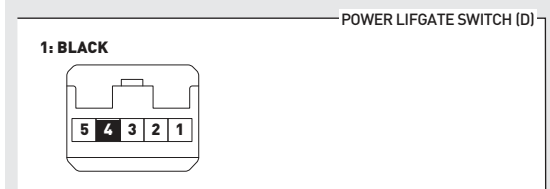
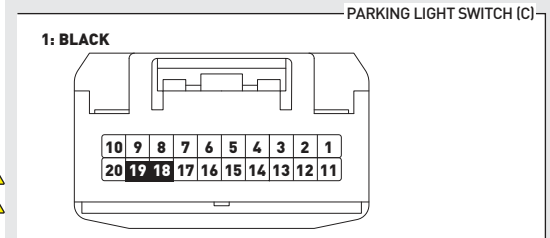
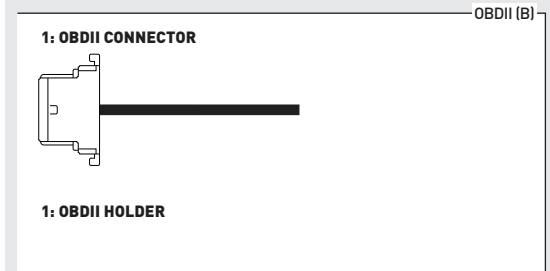
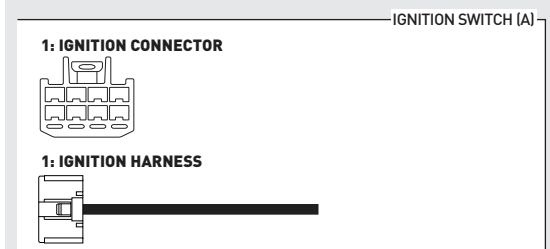

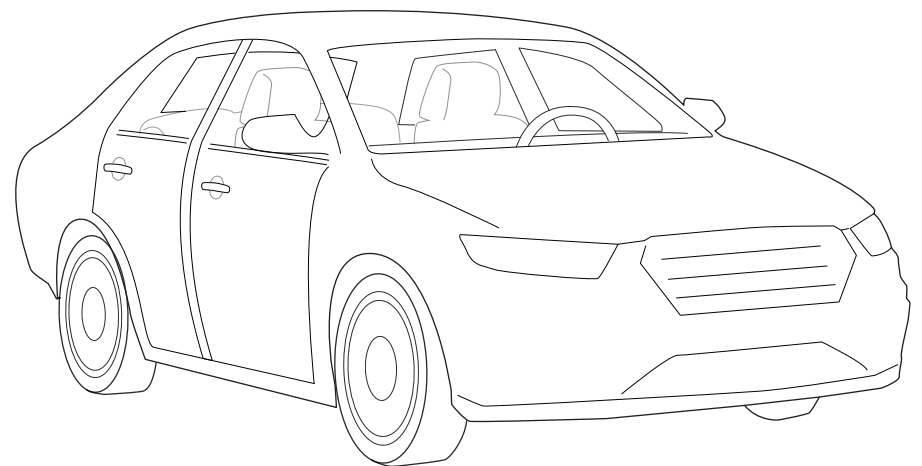
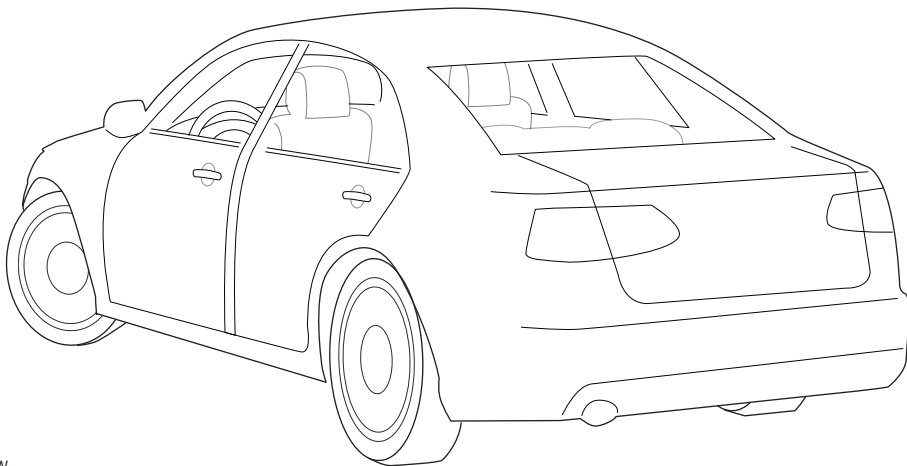
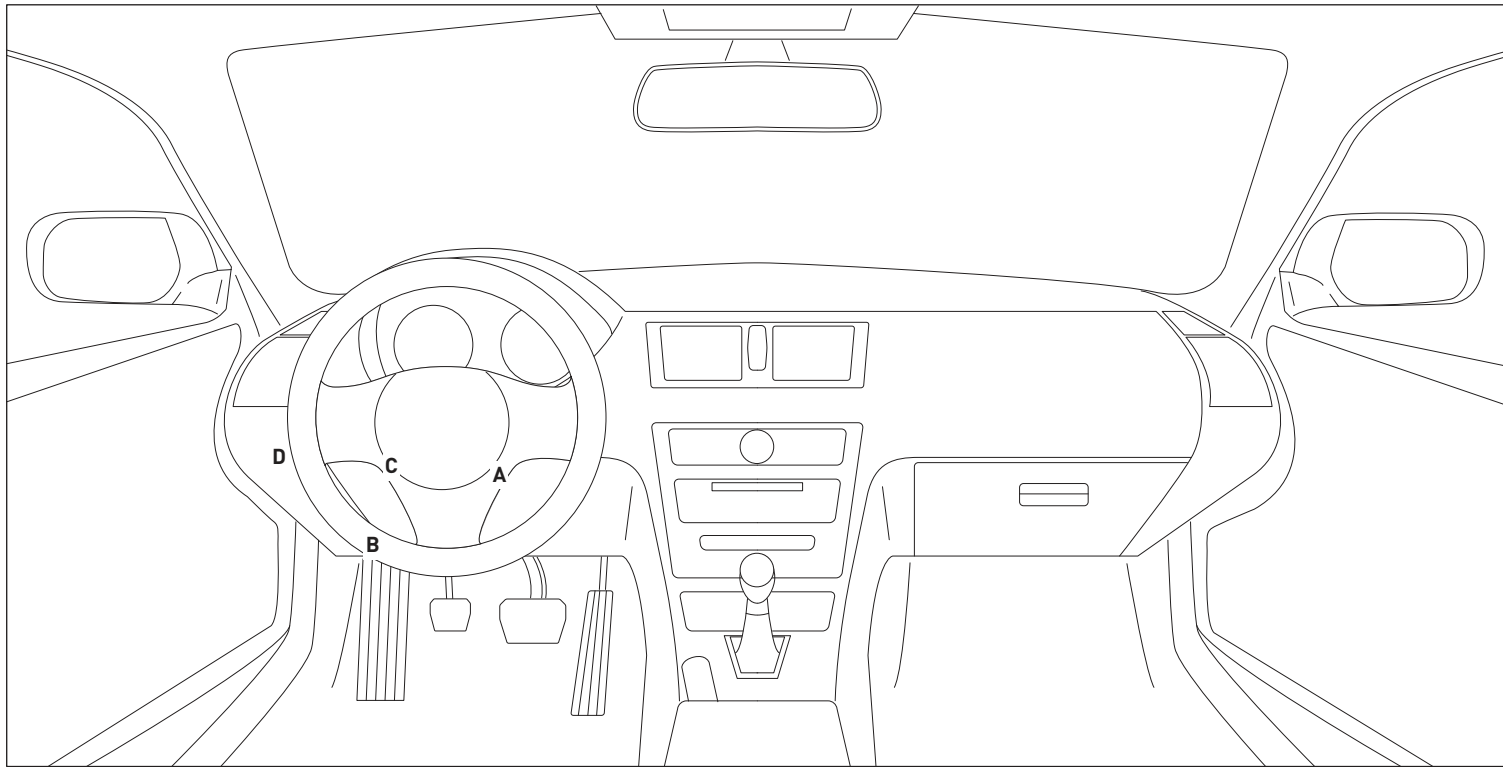

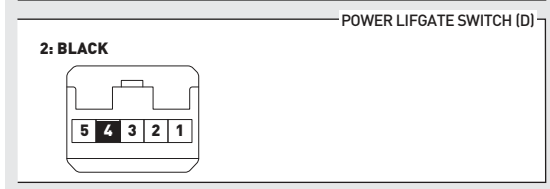
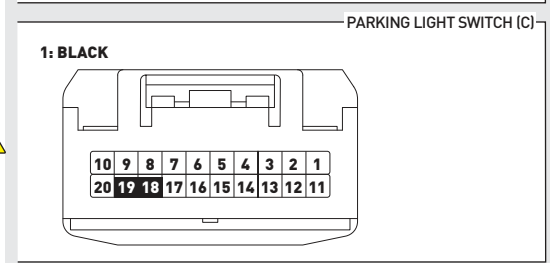
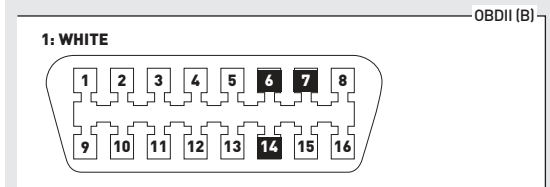
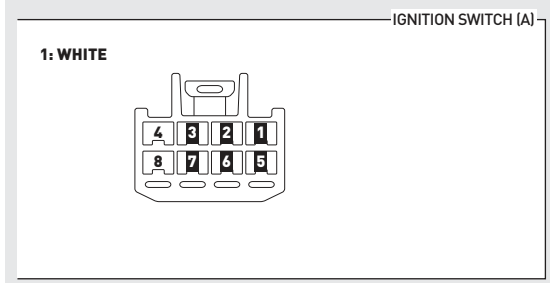
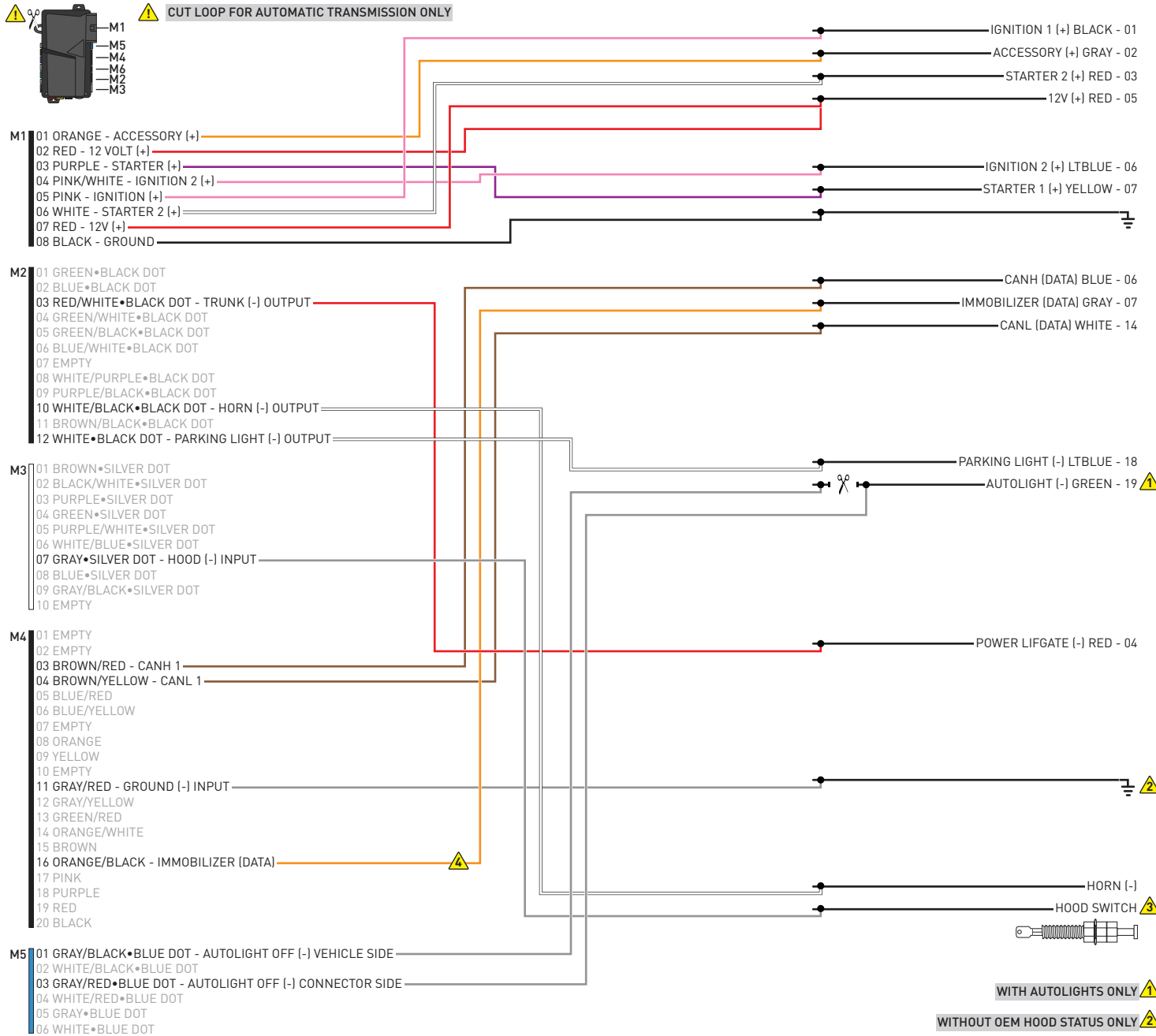

01  Use the BLACK key only. DO NOT use the GRAY valet key.

02  Turn key to ON position.

03  Wait, LED 1 will turn solid GREEN for 2 seconds.

04  Turn key to OFF position.

05  START vehicle for 15 seconds.

06  Press and hold the brake pedal.

07  Press and release the module's programming button.

08  Release the brake pedal.

09  Wait, LED 2 will flash GREEN.

10  Module Programming Procedure completed.

>>



All vehicle doors must be closed and locked prior to remote start sequence.

01



Press unlock on OEM or aftermarket remote or request switch.

02



DO NOT PRESS BRAKE PEDAL. Set ignition to ON position. Wait 2 seconds for key validation.

03



Press and release BRAKE pedal.

04



Take over procedure completed.

>>



Failure to follow procedure will result in vehicle engine shutdown.

CHECKLIST - WITH AFTERMARKET KEYFOB	
1	WARNING: Vehicle engine will start many times. Test in a well ventilated area.
2	Close all vehicle doors, hood and trunk.
3	Press the LOCK button once [1x] on the aftermarket keyfob.
	Question 1: Do the doors lock?
<input type="checkbox"/>	YES: Go to next step.
<input type="checkbox"/>	NO: Verify the remote programming, the RF connections and the wired door lock/unlock connections as illustrated in the wiring diagram, if applicable. Repeat the test and call technical support, if the problem persists.
4	Press the UNLOCK button once [1x] on the aftermarket keyfob.
	Question 2: Do the doors unlock?
<input type="checkbox"/>	YES: Go to next step.
<input type="checkbox"/>	NO: Verify the remote programming, the RF connections and the wired door lock/unlock connections as illustrated in the wiring diagram, if applicable. Repeat the test and call technical support, if the problem persists.
5	Press the TRUNK release button once [1x] on the aftermarket keyfob if supported.
	Question 3: Does the trunk or hatch open/unlock?
<input type="checkbox"/>	YES: Close trunk or hatch and go to next step.
<input type="checkbox"/>	NO: Verify the remote programming, the RF connections and the wired trunk/hatch connections as illustrated in the wiring diagram, if applicable. Repeat the test and call technical support, if the problem persists.
6	Press the AUX 1 button once [1x] on the aftermarket keyfob if supported.
	Question 4: Does the driver side sliding door open?
<input type="checkbox"/>	YES: Press the AUX 1 button once [1x] to close the driver sliding door and go to next step.
<input type="checkbox"/>	NO: Verify the remote programming and the RF connections. Repeat the test and call technical support, if the problem persists.
7	Press the AUX 2 button once [1x] on the aftermarket keyfob if supported.
	Question 5: Does the passenger side sliding door open?
<input type="checkbox"/>	YES: Press the AUX 2 button once [1x] to close the passenger sliding door and go to next step.
<input type="checkbox"/>	NO: Verify the remote programming and the RF connections. Repeat the test and call technical support, if the problem persists.
8	Press the START/STOP button once [1x] on the aftermarket keyfob to remote start vehicle.
	Question 6: Does the vehicle remote start?
<input type="checkbox"/>	YES: Go to next step.
<input type="checkbox"/>	NO: Verify the remote programming, the RF connections and check the remote start error codes. Repeat the test and call technical support, if the problem persists.
9	Press the START/STOP button once [1x] on the aftermarket keyfob to shut down vehicle.
	Question 7: Does the vehicle shut down?
<input type="checkbox"/>	YES: Go to next step.
<input type="checkbox"/>	NO: Repeat step. If problem persists, press the brake pedal once [1x] to shut down the vehicle and call technical support.
10	RAP and auto light shutdown test
	Question 8: Did the radio, interior controls and headlights turn off within 60 seconds after remote start shutdown?
<input type="checkbox"/>	YES: Go to next step.
<input type="checkbox"/>	NO: Verify the RAP SHUTDOWN connections as illustrated in the wiring diagram. Repeat the test and call technical support if the problem persists.
11	Open hood.
12	If not already installed, affix the mandatory orange warning sticker under the hood and proceed to next step.
13	Press the START/STOP button once [1x] on the aftermarket keyfob to remote start vehicle.
	Question 9: Does the vehicle remote start?
<input type="checkbox"/>	YES: The vehicle is not equipped with a factory hood pin. Install a mandatory aftermarket hood switch, then repeat the test.
<input type="checkbox"/>	NO: Go to next step.
14	Close hood.
15	Enter vehicle and close the doors.
16	Press the START/STOP button once [1x] on the aftermarket keyfob to remote start vehicle.
17	Wait for the vehicle to start.
18	Press brake pedal.
	Question 10: Does the vehicle shut down?
<input type="checkbox"/>	YES: Go to next step.
<input type="checkbox"/>	NO: The module does NOT detect the brake pedal signal. Press the START/STOP button once [1x] on the aftermarket keyfob to shut down vehicle, check connection as illustrated in the wiring diagram, if applicable, and call technical support.
19	Exit vehicle.
20	Installation checklist completed.

CHECKLIST - WITH OEM KEYFOB	
1	WARNING: Vehicle engine will start many times. Test in a well ventilated area.
2	Close all vehicle doors, hood and trunk.
3	Press LOCK button three times [3x] rapidly on the OEM keyfob to remote start vehicle.
	Question 1: Does the vehicle remote start?
<input type="checkbox"/>	YES: Go to next step.
<input type="checkbox"/>	NO: The module doesn't detect OEM remote lock button from the vehicle communication network. Check all connections, repeat the test and call technical support, if the problem persists.
4	Press LOCK button three times [3x] rapidly on the OEM keyfob to shut down vehicle.
	Question 2: Does the vehicle shut down?
<input type="checkbox"/>	YES: Go to next step.
<input type="checkbox"/>	NO: Repeat step. If the problem persists, press on the brake pedal once [1x] to shut down the vehicle and call technical support.
5	RAP Shutdown test
	Question 3: Did the radio, interior controls, and headlights turn off within 60 seconds after remote start shutdown?
<input type="checkbox"/>	YES: Go to next step.
<input type="checkbox"/>	NO: Verify the RAP SHUTDOWN connections as illustrated in the wiring diagram. Repeat the test and call technical support, if the problem persists.
6	Open hood.
7	If not already installed, affix the mandatory orange warning sticker under the hood and proceed to next step.
8	Press LOCK button three times [3x] rapidly on the OEM keyfob to remote start vehicle.
	Question 4: Does the vehicle remote start?
<input type="checkbox"/>	YES: The vehicle is not equipped with a factory hood pin. Install a mandatory aftermarket hood switch, then repeat the test.
<input type="checkbox"/>	NO: Go to next step.
9	Close hood.
10	Enter vehicle and close the doors.
11	Press LOCK button three times [3x] rapidly on the OEM keyfob to remote start vehicle.
12	Wait for the vehicle to start.
13	Press brake pedal.
	Question 5: Does the vehicle shut down?
<input type="checkbox"/>	YES: Go to next step.
<input type="checkbox"/>	NO: The module does NOT detect the brake pedal signal. Press LOCK button three times [3x] rapidly on the OEM keyfob to shut down, check the brake connection as illustrated in the wiring diagram, if applicable, and call technical support.
14	Exit vehicle.
15	Installation checklist completed.

COMPUSTAR®

INSTALL GUIDE

2012-2014 TOYOTA MATRIX 80-BIT STD KEY AT



DOCUMENT NUMBER

REVISION DATE

20180926

FIRMWARE

COM-RSA-TL5-[RS1B-DC3]

HARDWARE

RS1B-DC3

ACCESSORIES

ATTENTION: TO COMPLETE THIS INSTALLATION SOME ACCESSORIES MAY BE REQUIRED. VISIT OUR WEBSITE TO SEE ALL THE REQUIRED ACCESSORIES FOR YOUR VEHICLE.

TERMS OF USE

Automotive Data Solutions Inc. ("ADS") products are strictly intended for installation by Certified Technicians who are employed by a registered business specialized in the installation of automotive aftermarket electronics products. Prior to beginning installation of an ADS product in a vehicle, it is the Certified Technician's responsibility to review the most current Product Guide, Install Guide and vehicle-specific notes available in Weblink®. ADS is not responsible for any damages whatsoever, including but not limited to any consequential damages, incidental damages, damages for loss of time, loss of earnings, loss of profit, commercial loss, loss of economic opportunity and the like that may or may not have resulted from the use, misuse, improper installation or operation of its products. ADS reserves itself the right to suspend any Weblink® account without notice and decline to offer technical support to non-Certified Technicians, non-compliant Certified Technicians or end users.

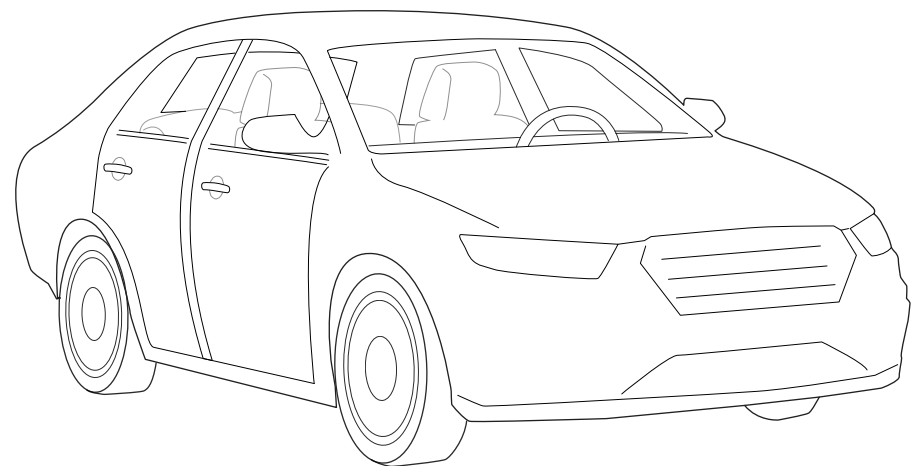
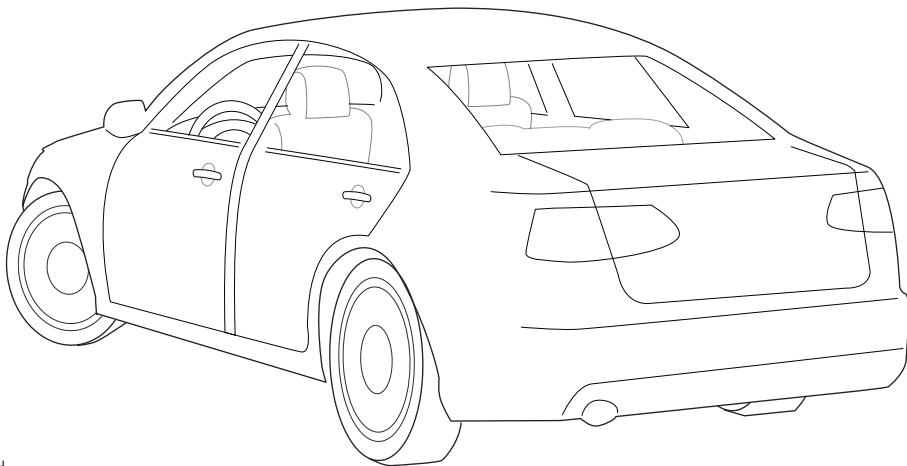
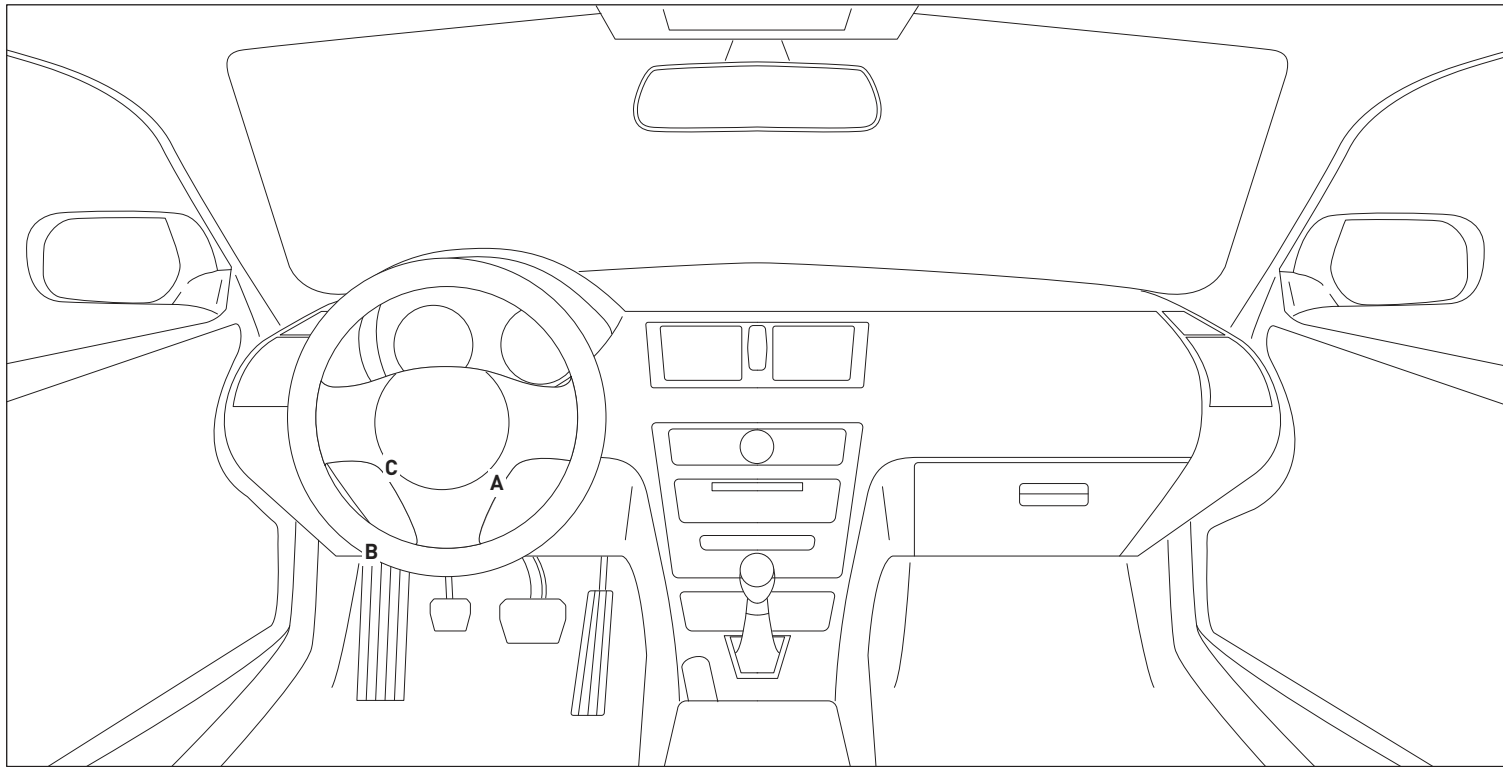

- CUT LOOP FOR AUTOMATIC TRANSMISSION ONLY
- SOME PARTS OF THE T-HARNESS (MS4-C, MS3-B, VS3/VS4 AND JS8) ARE NOT USED IN THIS INSTALL DO NOT CONNECT THEM.
- JS7 IS NOT USED IF THE VEHICLE IS EQUIPPED WITH AN IMMOBILIZER

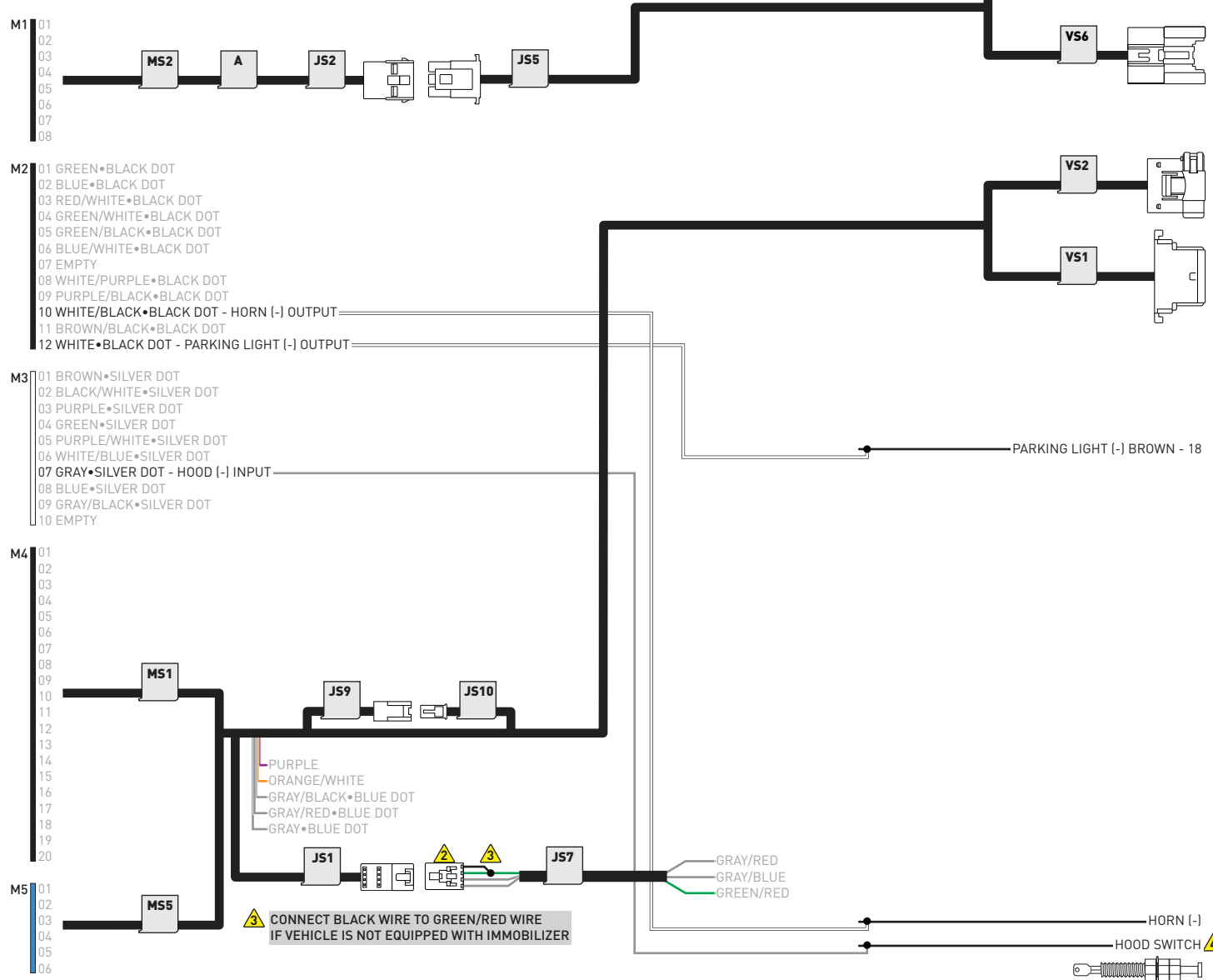

CONNECT BLACK WIRE TO GREEN/RED WIRE IF VEHICLE IS NOT EQUIPPED WITH IMMOBILIZER

IF NOT EQUIPPED WITH AN OEM HOOD PIN:
- INSTALL THE SUPPLIED HOOD SWITCH.
 - CHANGE REMOTE STARTER INPUT CONFIGURATION (MENU #7) "4- HOOD INPUT SOURCE" TO "1- ANALOG".

IGNITION SWITCH (A)

1: IGNITION CONNECTOR

1: IGNITION HARNESS

OBDII (B)

1: OBDII CONNECTOR

1: OBDII HOLDER

PARKING LIGHT SWITCH (C)

1

10	9	8	7	6	5	4	3	2	1
20	19	18	17	16	15	14	13	12	11

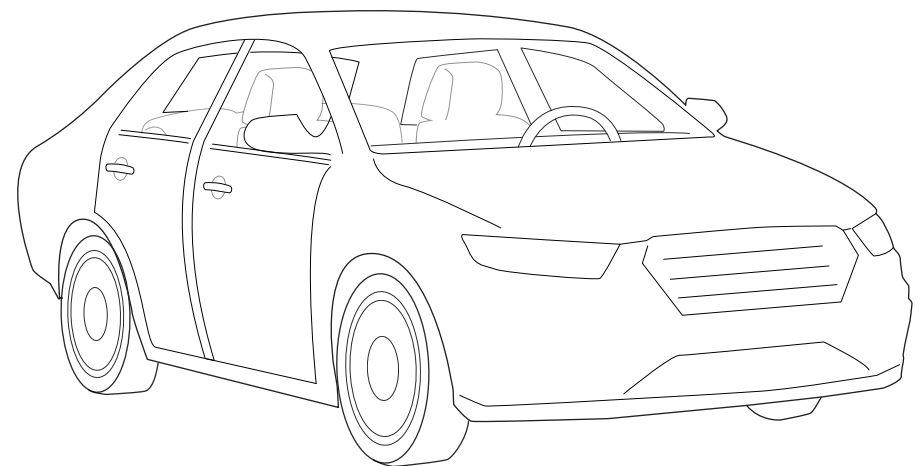
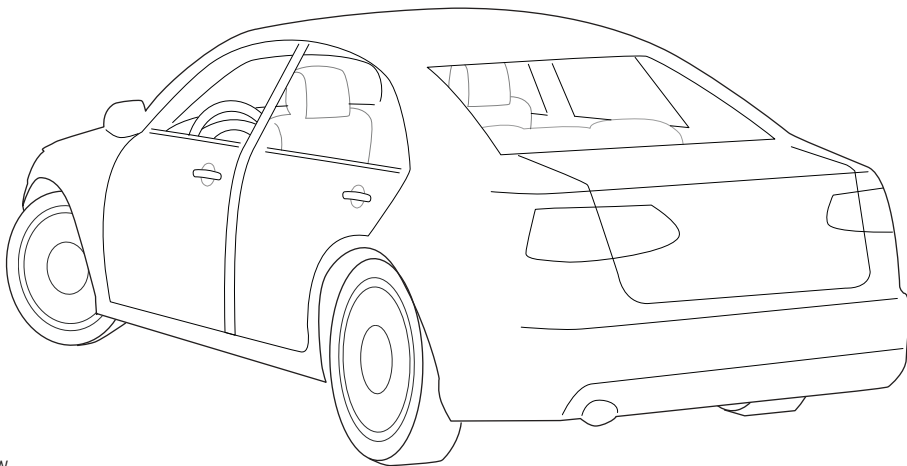
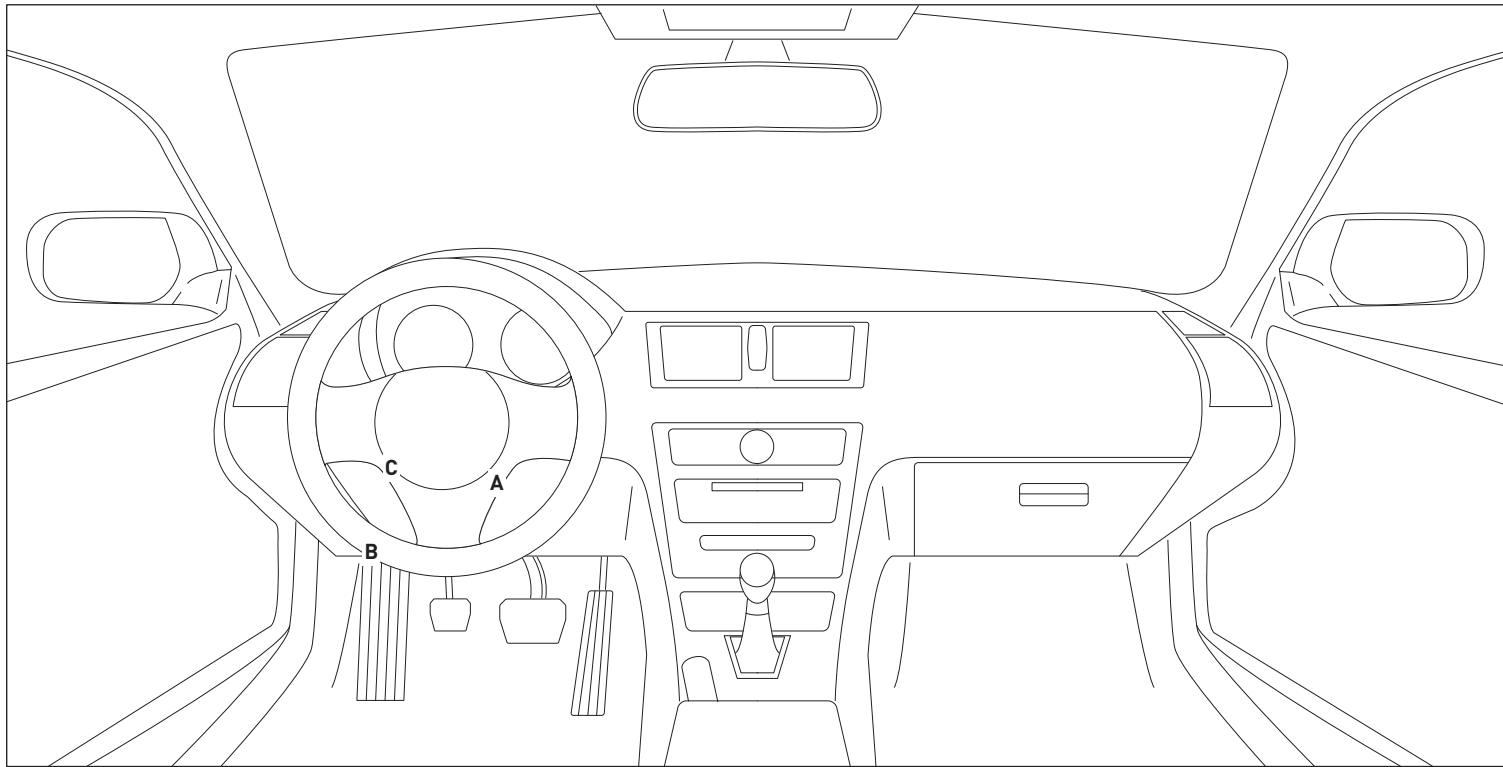

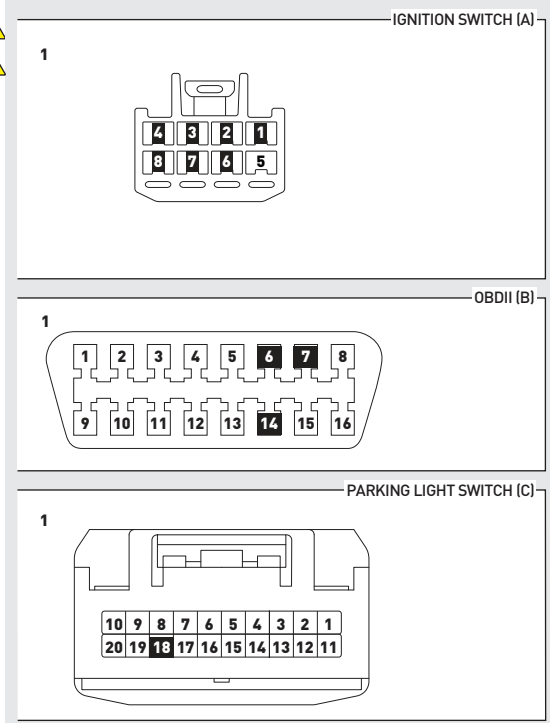
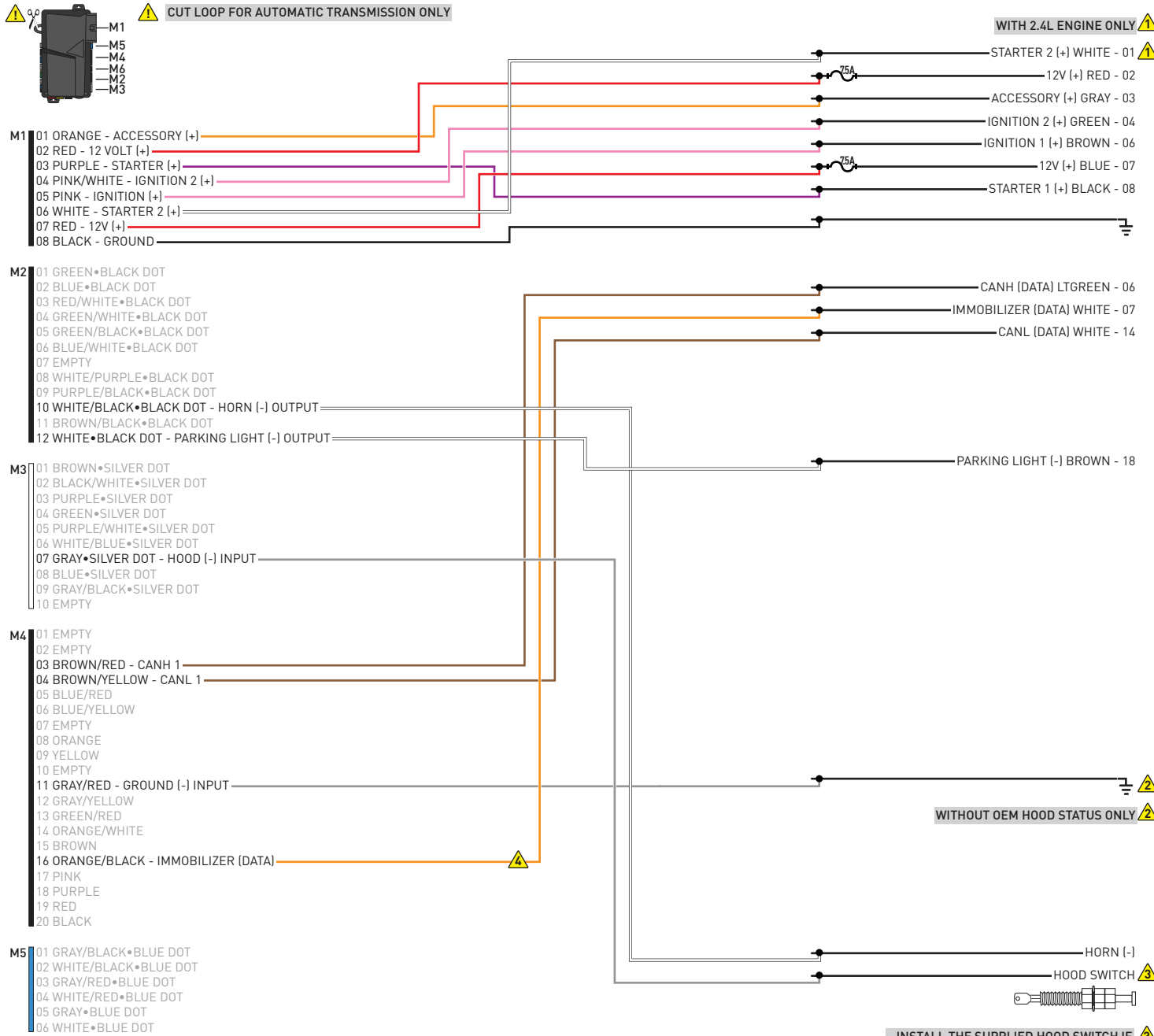

01  Use the BLACK key only. DO NOT use the GRAY valet key.

02  Turn key to ON position.

03  Wait, LED 1 will turn solid GREEN for 2 seconds.

04  Turn key to OFF position.

05  START vehicle for 15 seconds.

06  Press and hold the brake pedal.

07  Press and release the module's programming button.

08  Release the brake pedal.

09  Wait, LED 2 will flash GREEN.

10  Module Programming Procedure completed.

>>



All vehicle doors must be closed and locked prior to remote start sequence.

01



Press unlock on OEM or aftermarket remote or request switch.

02



DO NOT PRESS BRAKE PEDAL. Set ignition to ON position. Wait 2 seconds for key validation.

03



Press and release BRAKE pedal.

04



Take over procedure completed.

>>



Failure to follow procedure will result in vehicle engine shutdown.

CHECKLIST - WITH AFTERMARKET KEYFOB

1	WARNING: Vehicle engine will start many times. Test in a well ventilated area.	9	Press the START/STOP button once [1x] on the aftermarket keyfob to shut down vehicle.
2	Close all vehicle doors, hood and trunk.		Question 7: Does the vehicle shut down?
3	Press the LOCK button once [1x] on the aftermarket keyfob.	<input type="checkbox"/>	YES: Go to next step.
	Question 1: Do the doors lock?	<input type="checkbox"/>	NO: Repeat step. If problem persists, press the brake pedal once [1x] to shut down the vehicle and call technical support.
<input type="checkbox"/>	YES: Go to next step.	10	RAP and auto light shutdown test
<input type="checkbox"/>	NO: Verify the remote programming, the RF connections and the wired door lock/unlock connections as illustrated in the wiring diagram, if applicable. Repeat the test and call technical support, if the problem persists.		Question 8: Did the radio, interior controls and headlights turn off within 60 seconds after remote start shutdown?
4	Press the UNLOCK button once [1x] on the aftermarket keyfob.	<input type="checkbox"/>	YES: Go to next step.
	Question 2: Do the doors unlock?	<input type="checkbox"/>	NO: Verify the RAP SHUTDOWN connections as illustrated in the wiring diagram. Repeat the test and call technical support if the problem persists.
<input type="checkbox"/>	YES: Go to next step.	11	Open hood.
<input type="checkbox"/>	NO: Verify the remote programming, the RF connections and the wired door lock/unlock connections as illustrated in the wiring diagram, if applicable. Repeat the test and call technical support, if the problem persists.	12	If not already installed, affix the mandatory orange warning sticker under the hood and proceed to next step.
5	Press the TRUNK release button once [1x] on the aftermarket keyfob if supported.	13	Press the START/STOP button once [1x] on the aftermarket keyfob to remote start vehicle.
	Question 3: Does the trunk or hatch open/unlock?		Question 9: Does the vehicle remote start?
<input type="checkbox"/>	YES: Close trunk or hatch and go to next step.	<input type="checkbox"/>	YES: The vehicle is not equipped with a factory hood pin. Install a mandatory aftermarket hood switch, then repeat the test.
<input type="checkbox"/>	NO: Verify the remote programming, the RF connections and the wired trunk/hatch connections as illustrated in the wiring diagram, if applicable. Repeat the test and call technical support, if the problem persists.	<input type="checkbox"/>	NO: Go to next step.
6	Press the AUX 1 button once [1x] on the aftermarket keyfob if supported.	14	Close hood.
	Question 4: Does the driver side sliding door open?	15	Enter vehicle and close the doors.
<input type="checkbox"/>	YES: Press the AUX 1 button once [1x] to close the driver sliding door and go to next step.	16	Press the START/STOP button once [1x] on the aftermarket keyfob to remote start vehicle.
<input type="checkbox"/>	NO: Verify the remote programming and the RF connections. Repeat the test and call technical support, if the problem persists.	17	Wait for the vehicle to start.
7	Press the AUX 2 button once [1x] on the aftermarket keyfob if supported.	18	Press brake pedal.
	Question 5: Does the passenger side sliding door open?		Question 10: Does the vehicle shut down?
<input type="checkbox"/>	YES: Press the AUX 2 button once [1x] to close the passenger sliding door and go to next step.	<input type="checkbox"/>	YES: Go to next step.
<input type="checkbox"/>	NO: Verify the remote programming and the RF connections. Repeat the test and call technical support, if the problem persists.	<input type="checkbox"/>	NO: The module does NOT detect the brake pedal signal. Press the START/STOP button once [1x] on the aftermarket keyfob to shut down vehicle, check connection as illustrated in the wiring diagram, if applicable, and call technical support.
8	Press the START/STOP button once [1x] on the aftermarket keyfob to remote start vehicle.	19	Exit vehicle.
	Question 6: Does the vehicle remote start?	20	Installation checklist completed.
<input type="checkbox"/>	YES: Go to next step.		
<input type="checkbox"/>	NO: Verify the remote programming, the RF connections and check the remote start error codes. Repeat the test and call technical support, if the problem persists.		

CHECKLIST - WITH OEM KEYFOB	
1	WARNING: Vehicle engine will start many times. Test in a well ventilated area.
2	Close all vehicle doors, hood and trunk.
3	Press LOCK button three times [3x] rapidly on the OEM keyfob to remote start vehicle.
	Question 1: Does the vehicle remote start?
<input type="checkbox"/>	YES: Go to next step.
<input type="checkbox"/>	NO: The module doesn't detect OEM remote lock button from the vehicle communication network. Check all connections, repeat the test and call technical support, if the problem persists.
4	Press LOCK button three times [3x] rapidly on the OEM keyfob to shut down vehicle.
	Question 2: Does the vehicle shut down?
<input type="checkbox"/>	YES: Go to next step.
<input type="checkbox"/>	NO: Repeat step. If the problem persists, press on the brake pedal once [1x] to shut down the vehicle and call technical support.
5	RAP Shutdown test
	Question 3: Did the radio, interior controls, and headlights turn off within 60 seconds after remote start shutdown?
<input type="checkbox"/>	YES: Go to next step.
<input type="checkbox"/>	NO: Verify the RAP SHUTDOWN connections as illustrated in the wiring diagram. Repeat the test and call technical support, if the problem persists.
6	Open hood.
7	If not already installed, affix the mandatory orange warning sticker under the hood and proceed to next step.
8	Press LOCK button three times [3x] rapidly on the OEM keyfob to remote start vehicle.
	Question 4: Does the vehicle remote start?
<input type="checkbox"/>	YES: The vehicle is not equipped with a factory hood pin. Install a mandatory aftermarket hood switch, then repeat the test.
<input type="checkbox"/>	NO: Go to next step.
9	Close hood.
10	Enter vehicle and close the doors.
11	Press LOCK button three times [3x] rapidly on the OEM keyfob to remote start vehicle.
12	Wait for the vehicle to start.
13	Press brake pedal.
	Question 5: Does the vehicle shut down?
<input type="checkbox"/>	YES: Go to next step.
<input type="checkbox"/>	NO: The module does NOT detect the brake pedal signal. Press LOCK button three times [3x] rapidly on the OEM keyfob to shut down, check the brake connection as illustrated in the wiring diagram, if applicable, and call technical support.
14	Exit vehicle.
15	Installation checklist completed.

COMPUSTAR®

INSTALL GUIDE

2012-2014 TOYOTA PRIUS C 80-BIT STD KEY AT



DOCUMENT NUMBER

REVISION DATE

20180926

FIRMWARE

COM-RSA-TL5-[RS1B-DC3]

HARDWARE

RS1B-DC3

ACCESSORIES

ATTENTION: TO COMPLETE THIS INSTALLATION SOME ACCESSORIES MAY BE REQUIRED. VISIT OUR WEBSITE TO SEE ALL THE REQUIRED ACCESSORIES FOR YOUR VEHICLE.

TERMS OF USE

Automotive Data Solutions Inc. ("ADS") products are strictly intended for installation by Certified Technicians who are employed by a registered business specialized in the installation of automotive aftermarket electronics products. Prior to beginning installation of an ADS product in a vehicle, it is the Certified Technician's responsibility to review the most current Product Guide, Install Guide and vehicle-specific notes available in Weblink®. ADS is not responsible for any damages whatsoever, including but not limited to any consequential damages, incidental damages, damages for loss of time, loss of earnings, loss of profit, commercial loss, loss of economic opportunity and the like that may or may not have resulted from the use, misuse, improper installation or operation of its products. ADS reserves itself the right to suspend any Weblink® account without notice and decline to offer technical support to non-Certified Technicians, non-compliant Certified Technicians or end users.

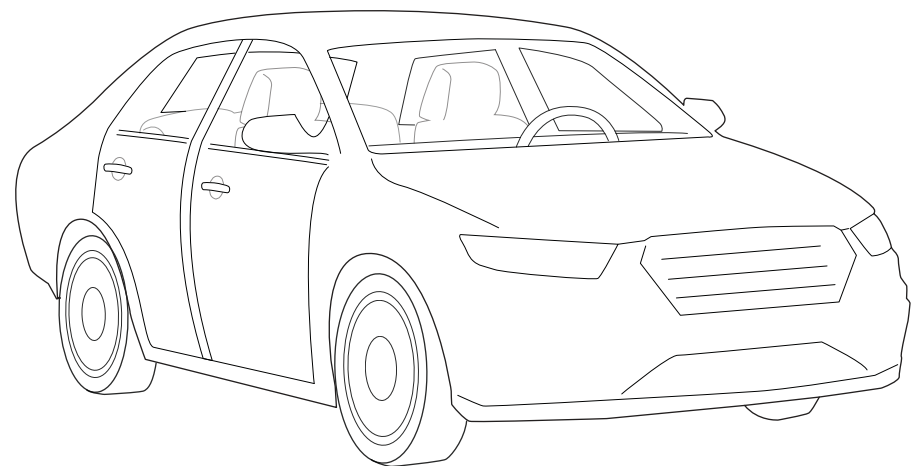
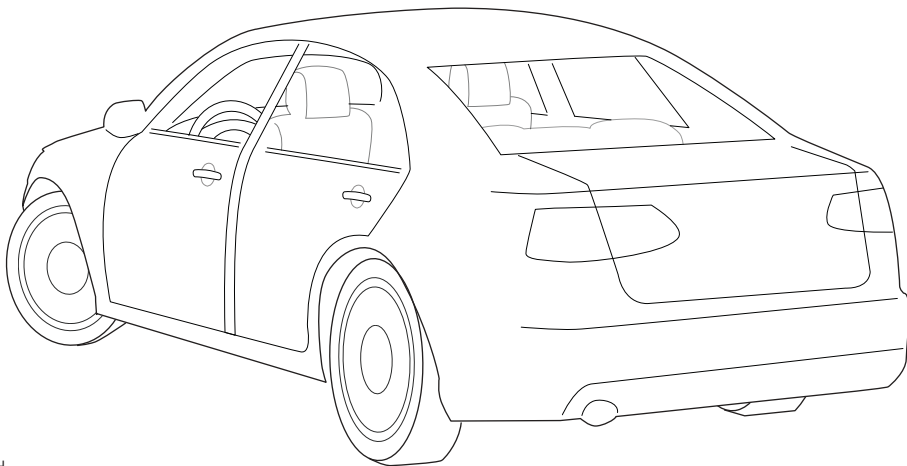
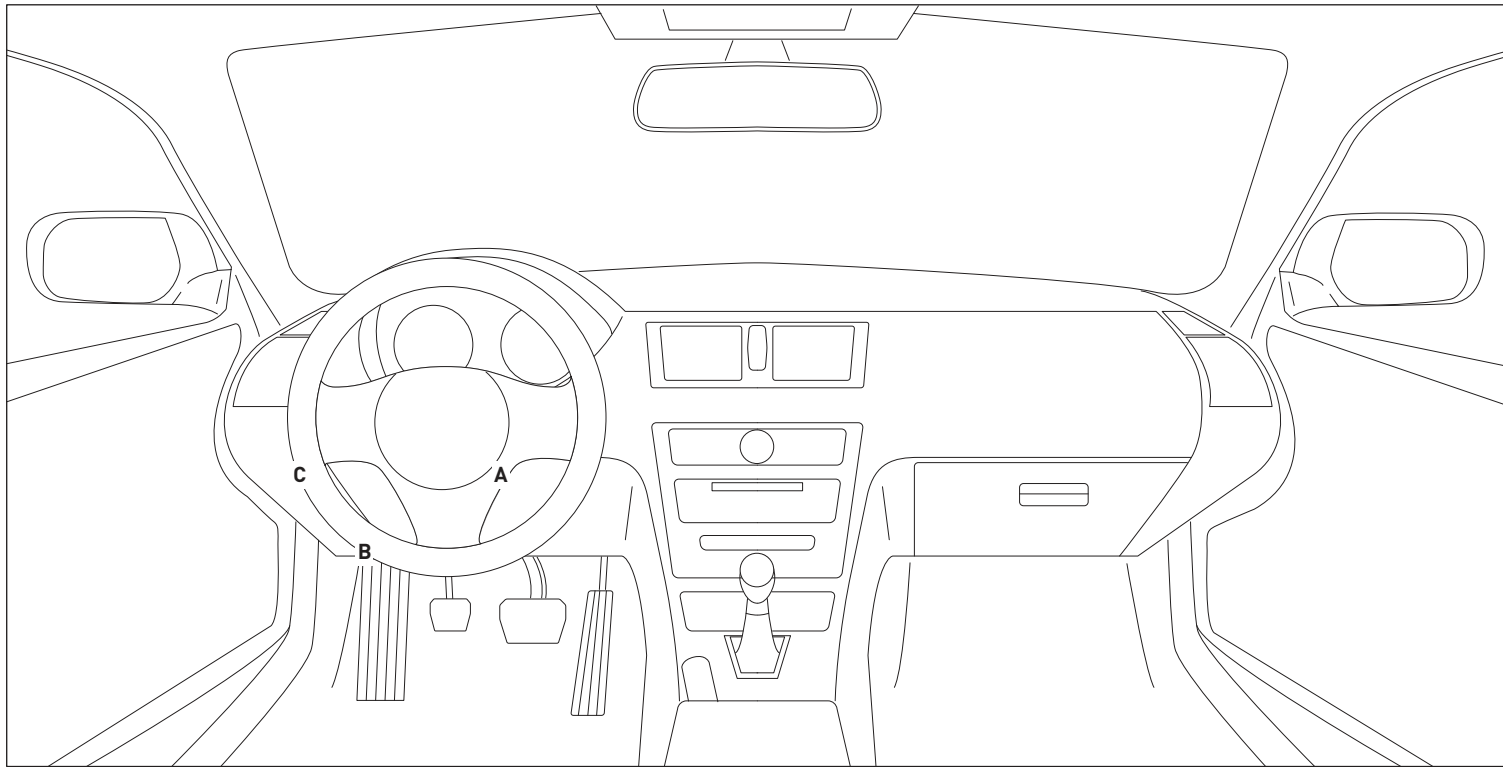

- CUT LOOP FOR AUTOMATIC TRANSMISSION ONLY
- SOME PARTS OF THE T-HARNESS (MS4-C, MS2-A, VS3/VS4 AND JS8) ARE NOT USED IN THIS INSTALL DO NOT CONNECT THEM.
- JS7 IS NOT USED IF THE VEHICLE IS EQUIPPED WITH AN IMMOBILIZER

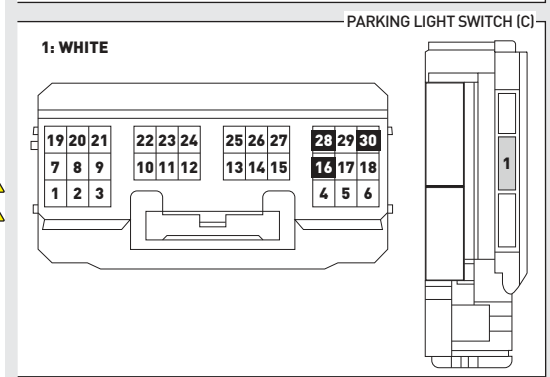
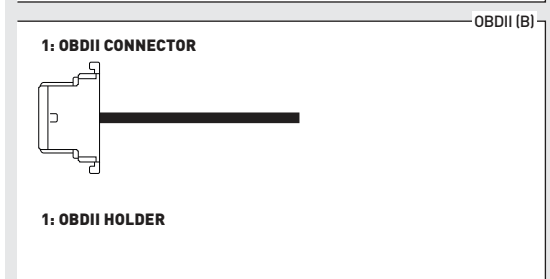
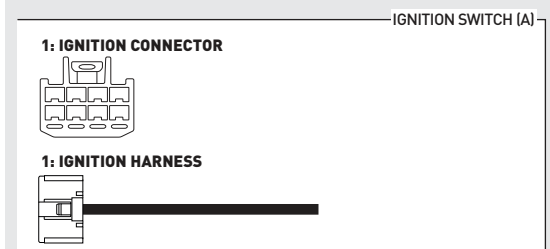
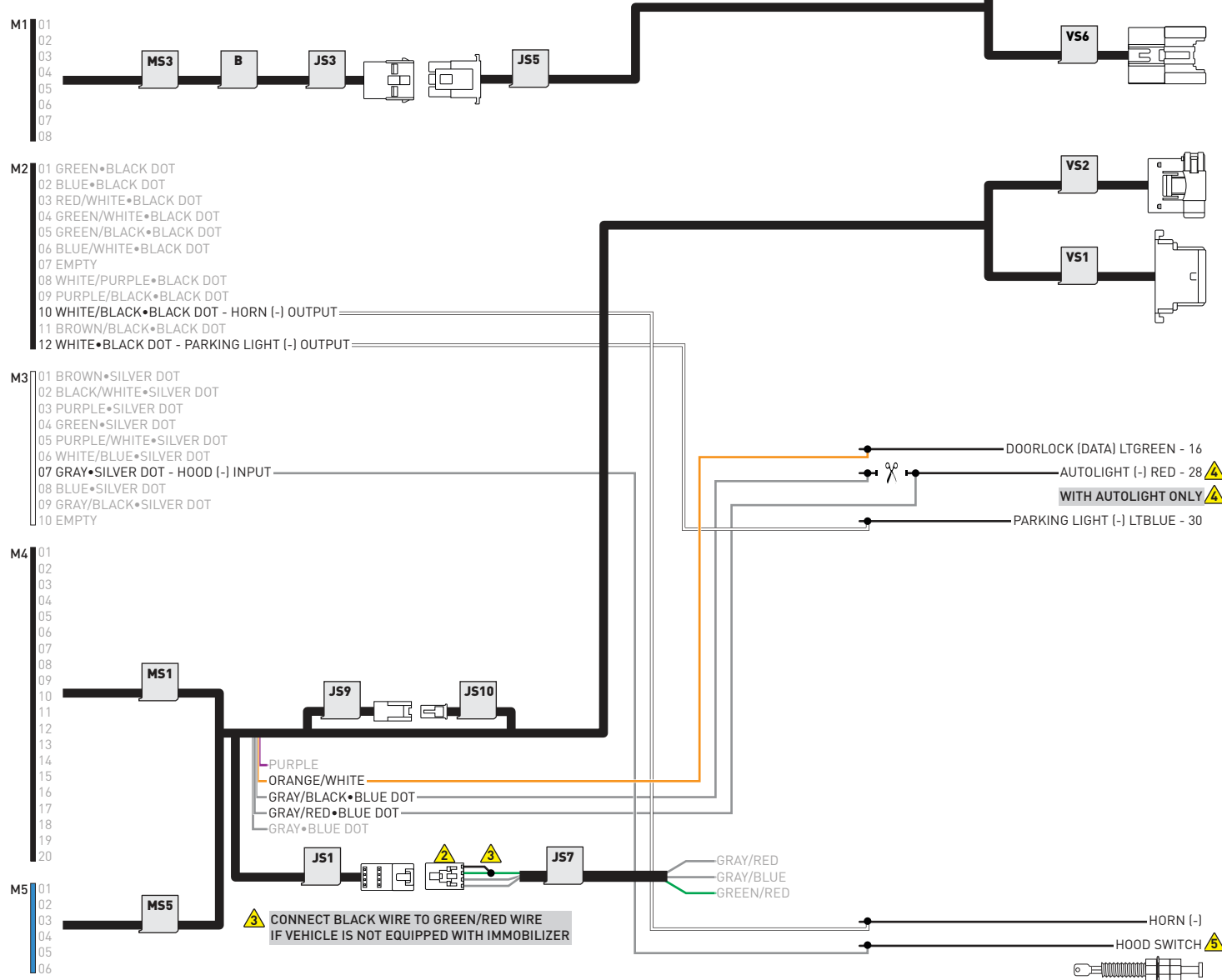

3 CONNECT BLACK WIRE TO GREEN/RED WIRE IF VEHICLE IS NOT EQUIPPED WITH IMMOBILIZER

5 IF NOT EQUIPPED WITH AN OEM HOOD PIN: - INSTALL THE SUPPLIED HOOD SWITCH.
- CHANGE REMOTE STARTER INPUT CONFIGURATION (MENU #7) "4- HOOD INPUT SOURCE" TO "1- ANALOG".

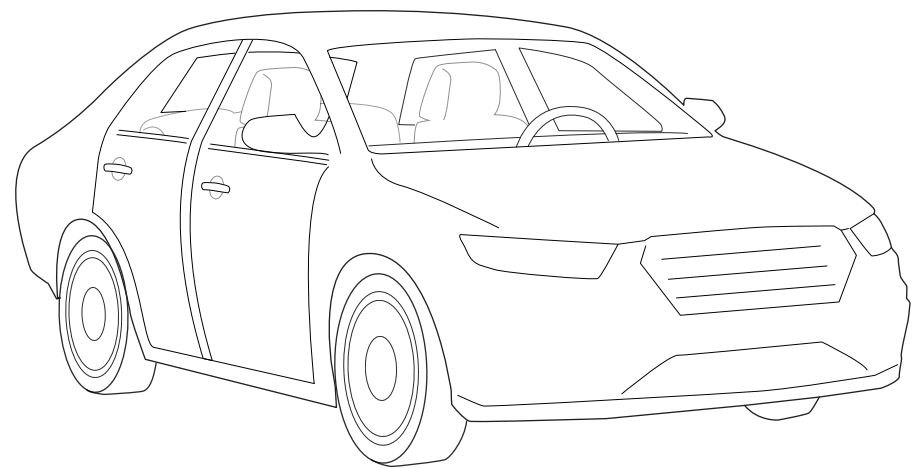
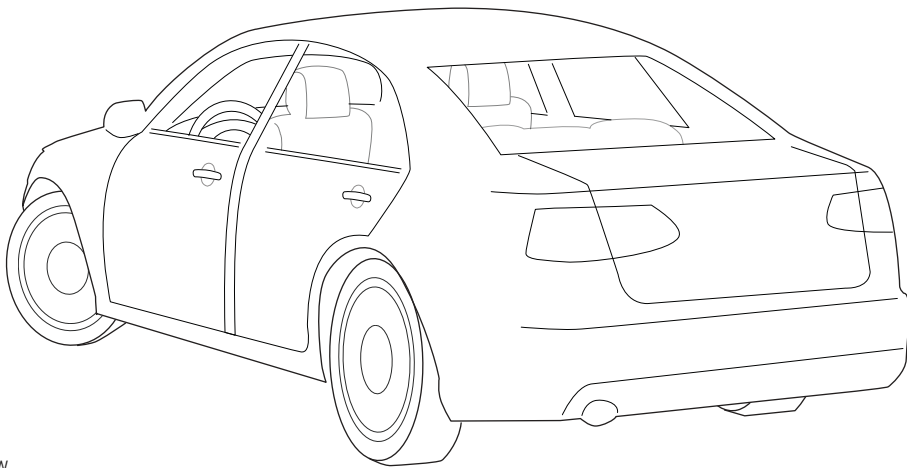
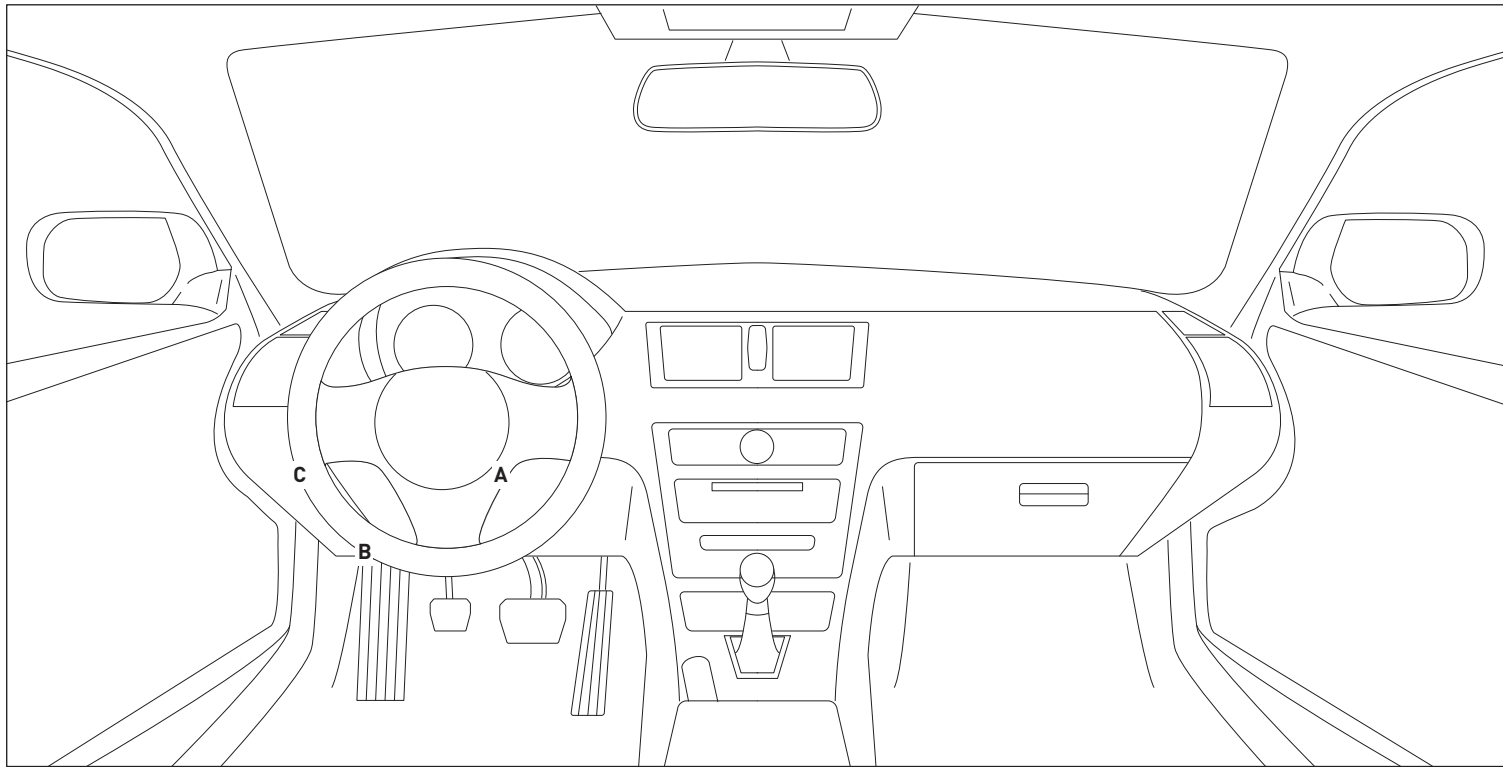

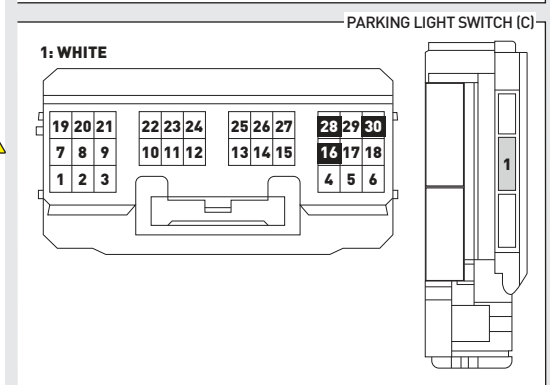
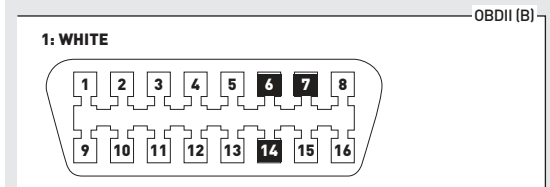
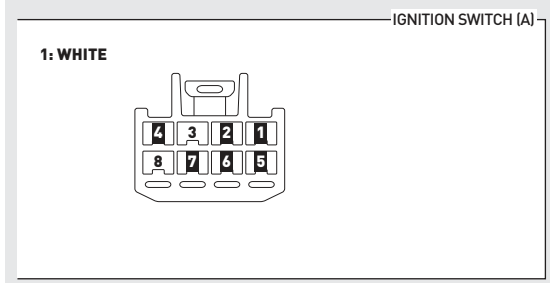
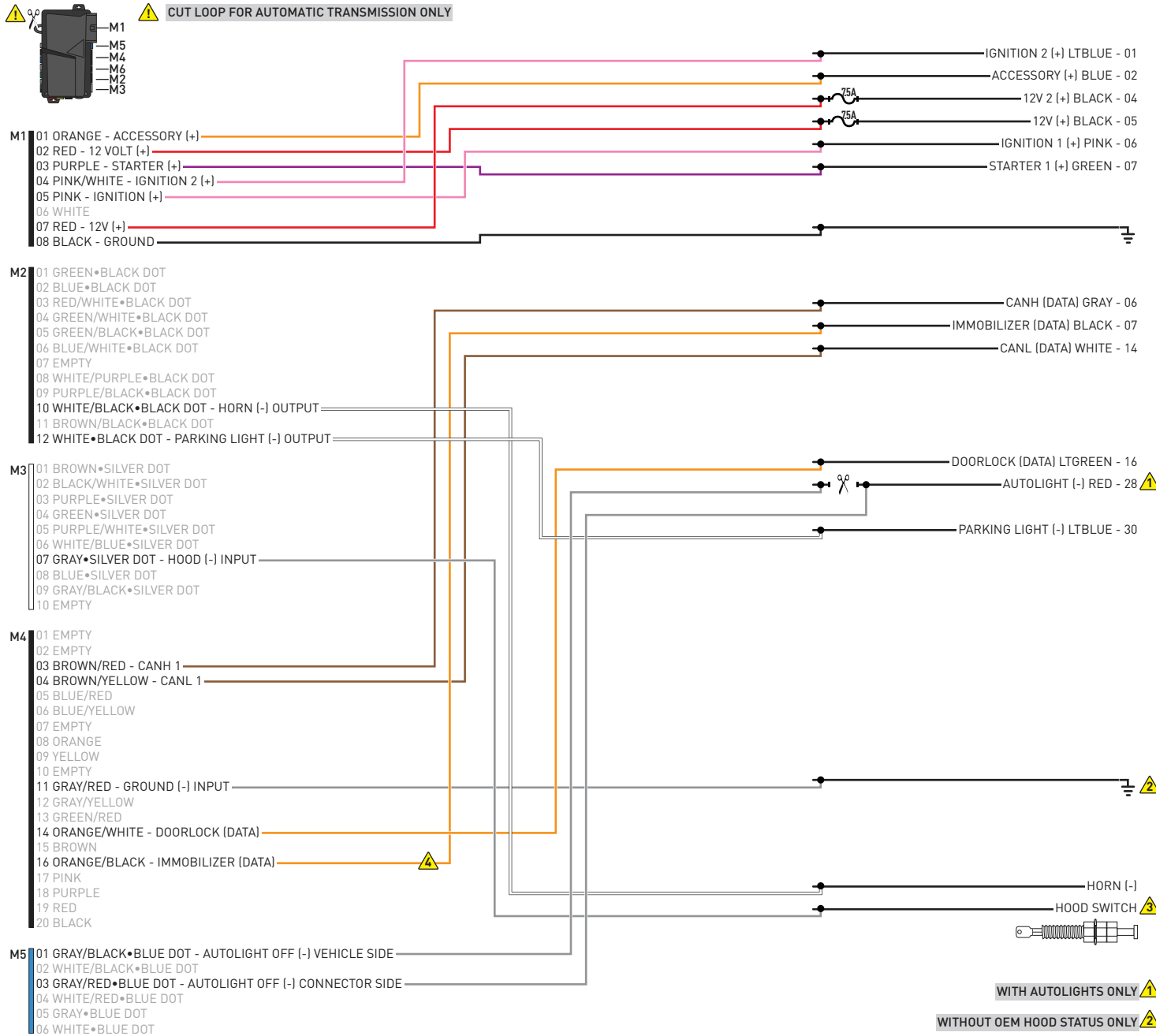

WITH AUTOLIGHTS ONLY ⚠

WITHOUT OEM HOOD STATUS ONLY ⚠

INSTALL THE SUPPLIED HOOD SWITCH IF THE VEHICLE IS NOT EQUIPPED WITH ONE. ⚠

CONNECT ORANGE/BLACK WIRE TO GROUND IF VEHICLE IS NOT EQUIPPED WITH IMMOBILIZER ⚠

01  Use the BLACK key only. DO NOT use the GRAY valet key.

02  Turn key to ON position.

03  Wait, LED 1 will turn solid GREEN for 2 seconds.

04  Turn key to OFF position.

05  START vehicle for 15 seconds.

06  Press and hold the brake pedal.

07  Press and release the module's programming button.

08  Release the brake pedal.

09  Wait, LED 2 will flash GREEN.

10  Module Programming Procedure completed.

>>



All vehicle doors must be closed and locked prior to remote start sequence.

01



Press unlock on OEM or aftermarket remote or request switch.

02



DO NOT PRESS BRAKE PEDAL. Set ignition to ON position. Wait 2 seconds for key validation.

03



Press and release BRAKE pedal.

04



Take over procedure completed.

>>



Failure to follow procedure will result in vehicle engine shutdown.

CHECKLIST - WITH AFTERMARKET KEYFOB	
1	WARNING: Vehicle engine will start many times. Test in a well ventilated area.
2	Close all vehicle doors, hood and trunk.
3	Press the LOCK button once [1x] on the aftermarket keyfob.
	Question 1: Do the doors lock?
<input type="checkbox"/>	YES: Go to next step.
<input type="checkbox"/>	NO: Verify the remote programming, the RF connections and the wired door lock/unlock connections as illustrated in the wiring diagram, if applicable. Repeat the test and call technical support, if the problem persists.
4	Press the UNLOCK button once [1x] on the aftermarket keyfob.
	Question 2: Do the doors unlock?
<input type="checkbox"/>	YES: Go to next step.
<input type="checkbox"/>	NO: Verify the remote programming, the RF connections and the wired door lock/unlock connections as illustrated in the wiring diagram, if applicable. Repeat the test and call technical support, if the problem persists.
5	Press the TRUNK release button once [1x] on the aftermarket keyfob if supported.
	Question 3: Does the trunk or hatch open/unlock?
<input type="checkbox"/>	YES: Close trunk or hatch and go to next step.
<input type="checkbox"/>	NO: Verify the remote programming, the RF connections and the wired trunk/hatch connections as illustrated in the wiring diagram, if applicable. Repeat the test and call technical support, if the problem persists.
6	Press the AUX 1 button once [1x] on the aftermarket keyfob if supported.
	Question 4: Does the driver side sliding door open?
<input type="checkbox"/>	YES: Press the AUX 1 button once [1x] to close the driver sliding door and go to next step.
<input type="checkbox"/>	NO: Verify the remote programming and the RF connections. Repeat the test and call technical support, if the problem persists.
7	Press the AUX 2 button once [1x] on the aftermarket keyfob if supported.
	Question 5: Does the passenger side sliding door open?
<input type="checkbox"/>	YES: Press the AUX 2 button once [1x] to close the passenger sliding door and go to next step.
<input type="checkbox"/>	NO: Verify the remote programming and the RF connections. Repeat the test and call technical support, if the problem persists.
8	Press the START/STOP button once [1x] on the aftermarket keyfob to remote start vehicle.
	Question 6: Does the vehicle remote start?
<input type="checkbox"/>	YES: Go to next step.
<input type="checkbox"/>	NO: Verify the remote programming, the RF connections and check the remote start error codes. Repeat the test and call technical support, if the problem persists.
9	Press the START/STOP button once [1x] on the aftermarket keyfob to shut down vehicle.
	Question 7: Does the vehicle shut down?
<input type="checkbox"/>	YES: Go to next step.
<input type="checkbox"/>	NO: Repeat step. If problem persists, press the brake pedal once [1x] to shut down the vehicle and call technical support.
10	RAP and auto light shutdown test
	Question 8: Did the radio, interior controls and headlights turn off within 60 seconds after remote start shutdown?
<input type="checkbox"/>	YES: Go to next step.
<input type="checkbox"/>	NO: Verify the RAP SHUTDOWN connections as illustrated in the wiring diagram. Repeat the test and call technical support if the problem persists.
11	Open hood.
12	If not already installed, affix the mandatory orange warning sticker under the hood and proceed to next step.
13	Press the START/STOP button once [1x] on the aftermarket keyfob to remote start vehicle.
	Question 9: Does the vehicle remote start?
<input type="checkbox"/>	YES: The vehicle is not equipped with a factory hood pin. Install a mandatory aftermarket hood switch, then repeat the test.
<input type="checkbox"/>	NO: Go to next step.
14	Close hood.
15	Enter vehicle and close the doors.
16	Press the START/STOP button once [1x] on the aftermarket keyfob to remote start vehicle.
17	Wait for the vehicle to start.
18	Press brake pedal.
	Question 10: Does the vehicle shut down?
<input type="checkbox"/>	YES: Go to next step.
<input type="checkbox"/>	NO: The module does NOT detect the brake pedal signal. Press the START/STOP button once [1x] on the aftermarket keyfob to shut down vehicle, check connection as illustrated in the wiring diagram, if applicable, and call technical support.
19	Exit vehicle.
20	Installation checklist completed.

CHECKLIST - WITH OEM KEYFOB	
1	WARNING: Vehicle engine will start many times. Test in a well ventilated area.
2	Close all vehicle doors, hood and trunk.
3	Press LOCK button three times [3x] rapidly on the OEM keyfob to remote start vehicle.
	Question 1: Does the vehicle remote start?
<input type="checkbox"/>	YES: Go to next step.
<input type="checkbox"/>	NO: The module doesn't detect OEM remote lock button from the vehicle communication network. Check all connections, repeat the test and call technical support, if the problem persists.
4	Press LOCK button three times [3x] rapidly on the OEM keyfob to shut down vehicle.
	Question 2: Does the vehicle shut down?
<input type="checkbox"/>	YES: Go to next step.
<input type="checkbox"/>	NO: Repeat step. If the problem persists, press on the brake pedal once [1x] to shut down the vehicle and call technical support.
5	RAP Shutdown test
	Question 3: Did the radio, interior controls, and headlights turn off within 60 seconds after remote start shutdown?
<input type="checkbox"/>	YES: Go to next step.
<input type="checkbox"/>	NO: Verify the RAP SHUTDOWN connections as illustrated in the wiring diagram. Repeat the test and call technical support, if the problem persists.
6	Open hood.
7	If not already installed, affix the mandatory orange warning sticker under the hood and proceed to next step.
8	Press LOCK button three times [3x] rapidly on the OEM keyfob to remote start vehicle.
	Question 4: Does the vehicle remote start?
<input type="checkbox"/>	YES: The vehicle is not equipped with a factory hood pin. Install a mandatory aftermarket hood switch, then repeat the test.
<input type="checkbox"/>	NO: Go to next step.
9	Close hood.
10	Enter vehicle and close the doors.
11	Press LOCK button three times [3x] rapidly on the OEM keyfob to remote start vehicle.
12	Wait for the vehicle to start.
13	Press brake pedal.
	Question 5: Does the vehicle shut down?
<input type="checkbox"/>	YES: Go to next step.
<input type="checkbox"/>	NO: The module does NOT detect the brake pedal signal. Press LOCK button three times [3x] rapidly on the OEM keyfob to shut down, check the brake connection as illustrated in the wiring diagram, if applicable, and call technical support.
14	Exit vehicle.
15	Installation checklist completed.

COMPUSTAR®

INSTALL GUIDE

2011-2012 TOYOTA RAV4 80-BIT STD KEY AT



DOCUMENT NUMBER

REVISION DATE

20180926

FIRMWARE

COM-RSA-TL5-[RS1B-DC3]

HARDWARE

RS1B-DC3

ACCESSORIES

ATTENTION: TO COMPLETE THIS INSTALLATION SOME ACCESSORIES MAY BE REQUIRED. VISIT OUR WEBSITE TO SEE ALL THE REQUIRED ACCESSORIES FOR YOUR VEHICLE.

TERMS OF USE

Automotive Data Solutions Inc. ("ADS") products are strictly intended for installation by Certified Technicians who are employed by a registered business specialized in the installation of automotive aftermarket electronics products. Prior to beginning installation of an ADS product in a vehicle, it is the Certified Technician's responsibility to review the most current Product Guide, Install Guide and vehicle-specific notes available in Weblink®. ADS is not responsible for any damages whatsoever, including but not limited to any consequential damages, incidental damages, damages for loss of time, loss of earnings, loss of profit, commercial loss, loss of economic opportunity and the like that may or may not have resulted from the use, misuse, improper installation or operation of its products. ADS reserves itself the right to suspend any Weblink® account without notice and decline to offer technical support to non-Certified Technicians, non-compliant Certified Technicians or end users.

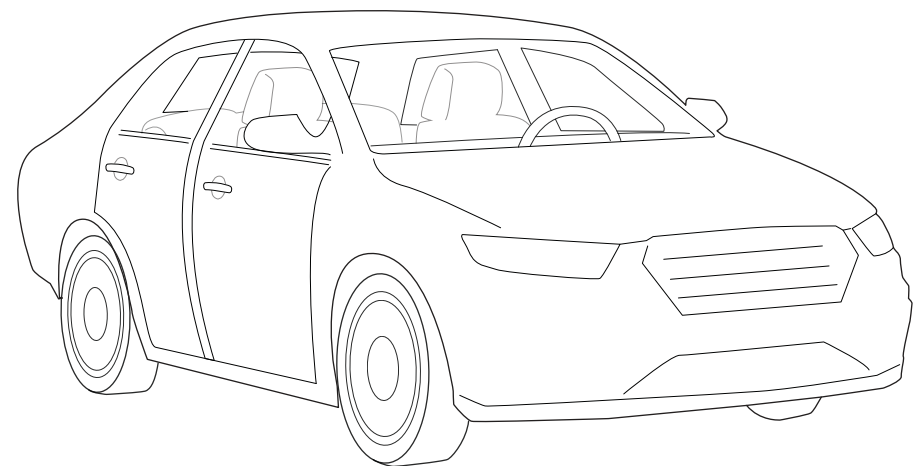
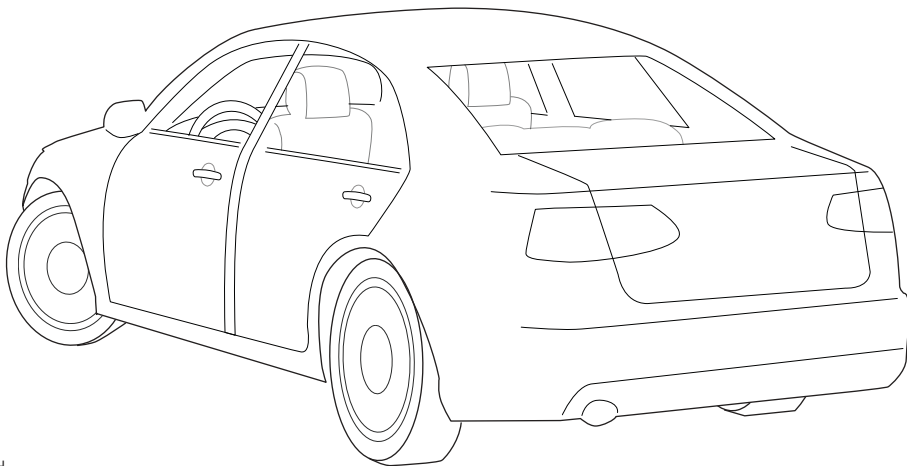
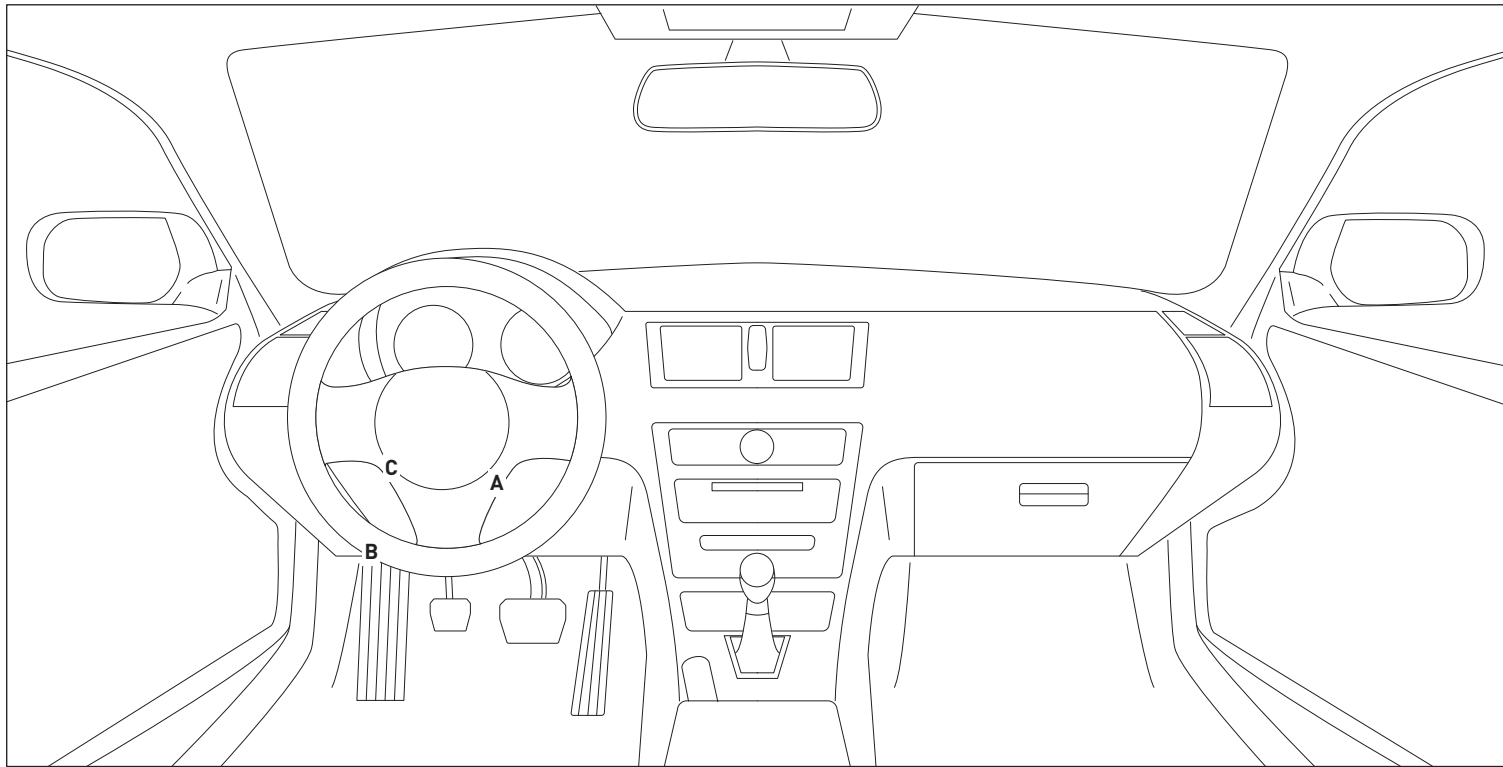

- CUT LOOP FOR AUTOMATIC TRANSMISSION ONLY
- SOME PARTS OF THE T-HARNESS (MS4-C, MS3-B, VS3/VS4 AND JS8) ARE NOT USED IN THIS INSTALL DO NOT CONNECT THEM.
- JS7 IS NOT USED IF THE VEHICLE IS EQUIPPED WITH AN IMMOBILIZER

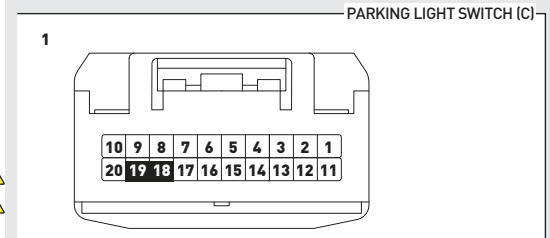
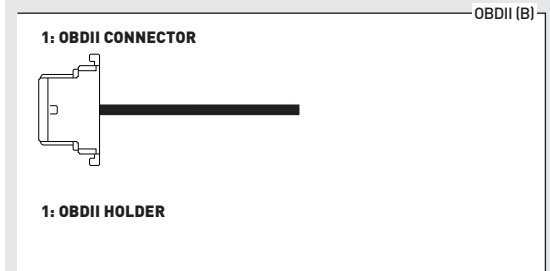
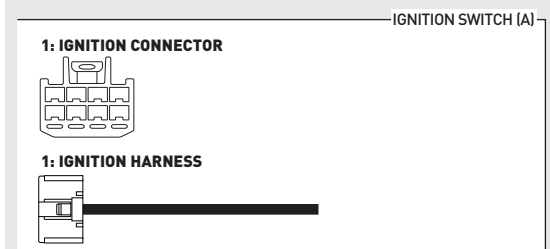
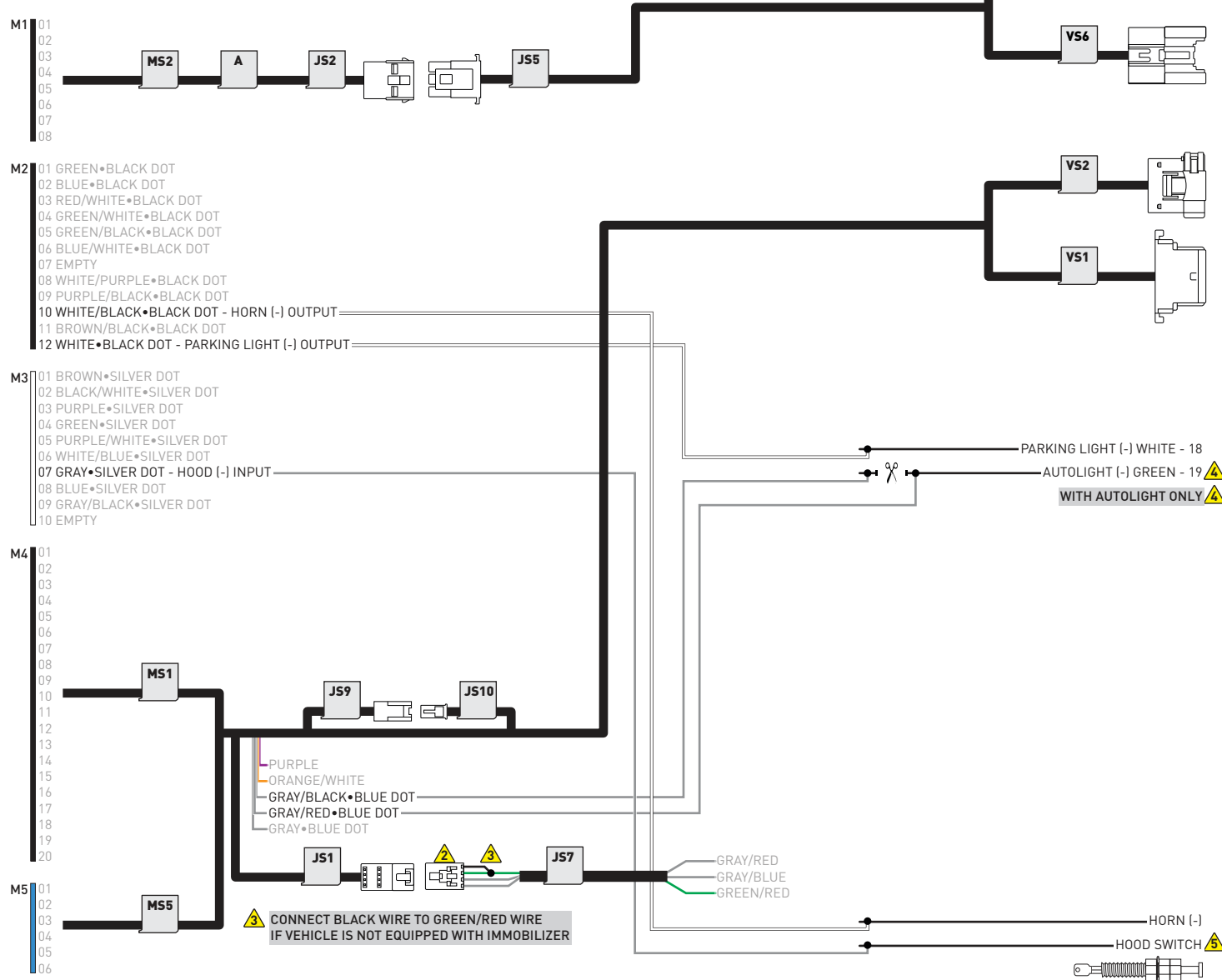

3 CONNECT BLACK WIRE TO GREEN/RED WIRE IF VEHICLE IS NOT EQUIPPED WITH IMMOBILIZER

5 IF NOT EQUIPPED WITH AN OEM HOOD PIN:
- INSTALL THE SUPPLIED HOOD SWITCH.
- CHANGE REMOTE STARTER INPUT CONFIGURATION (MENU #7) "4- HOOD INPUT SOURCE" TO "1- ANALOG".

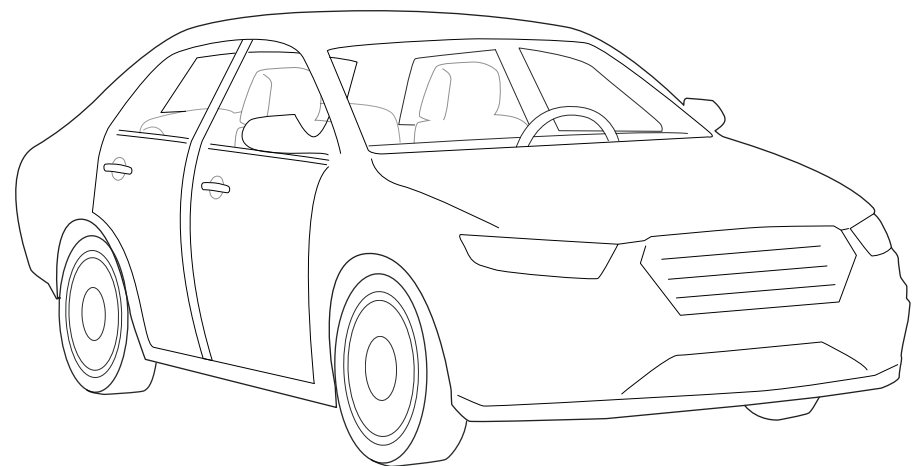
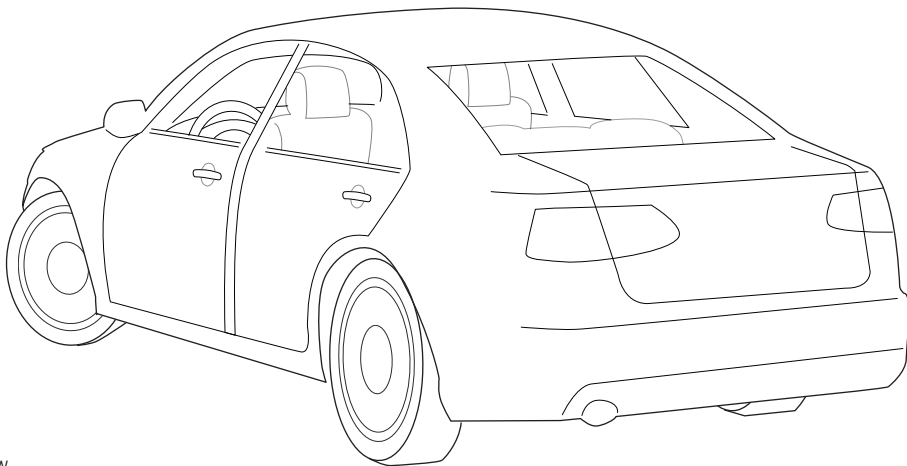
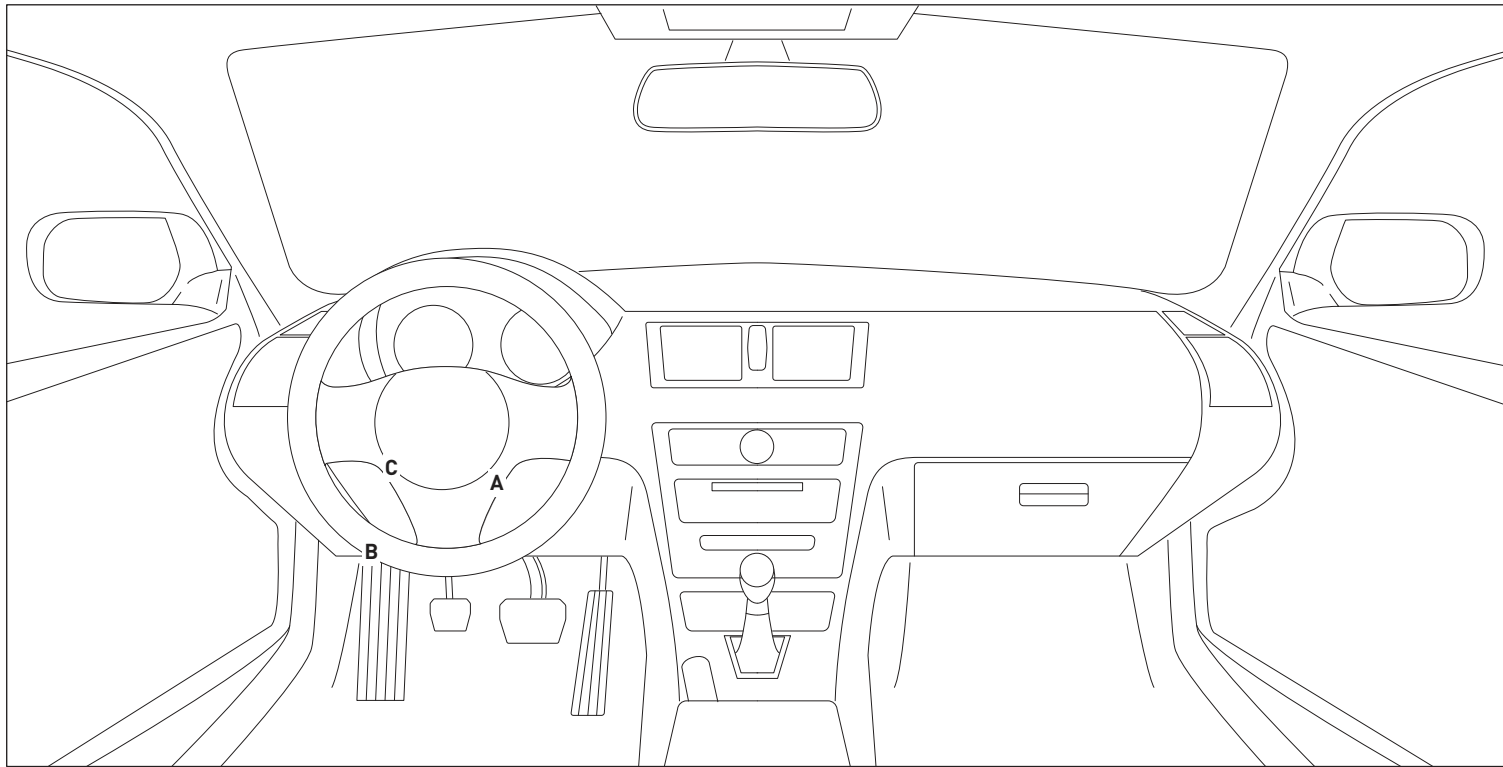

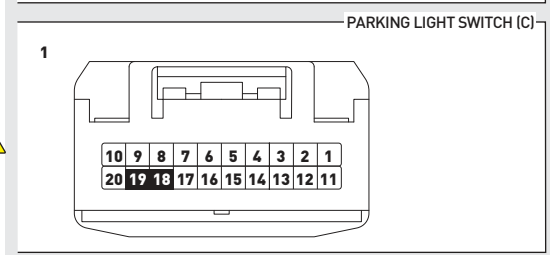
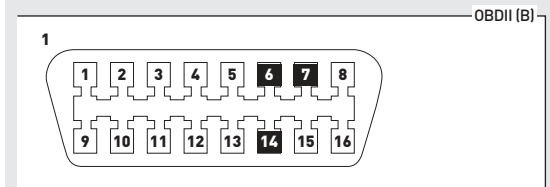
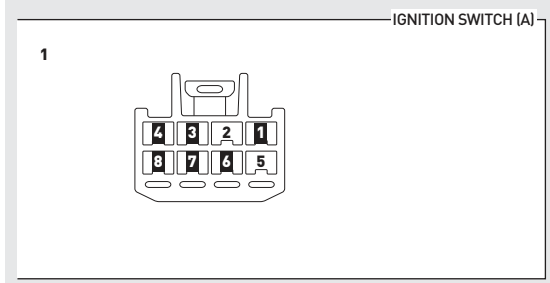
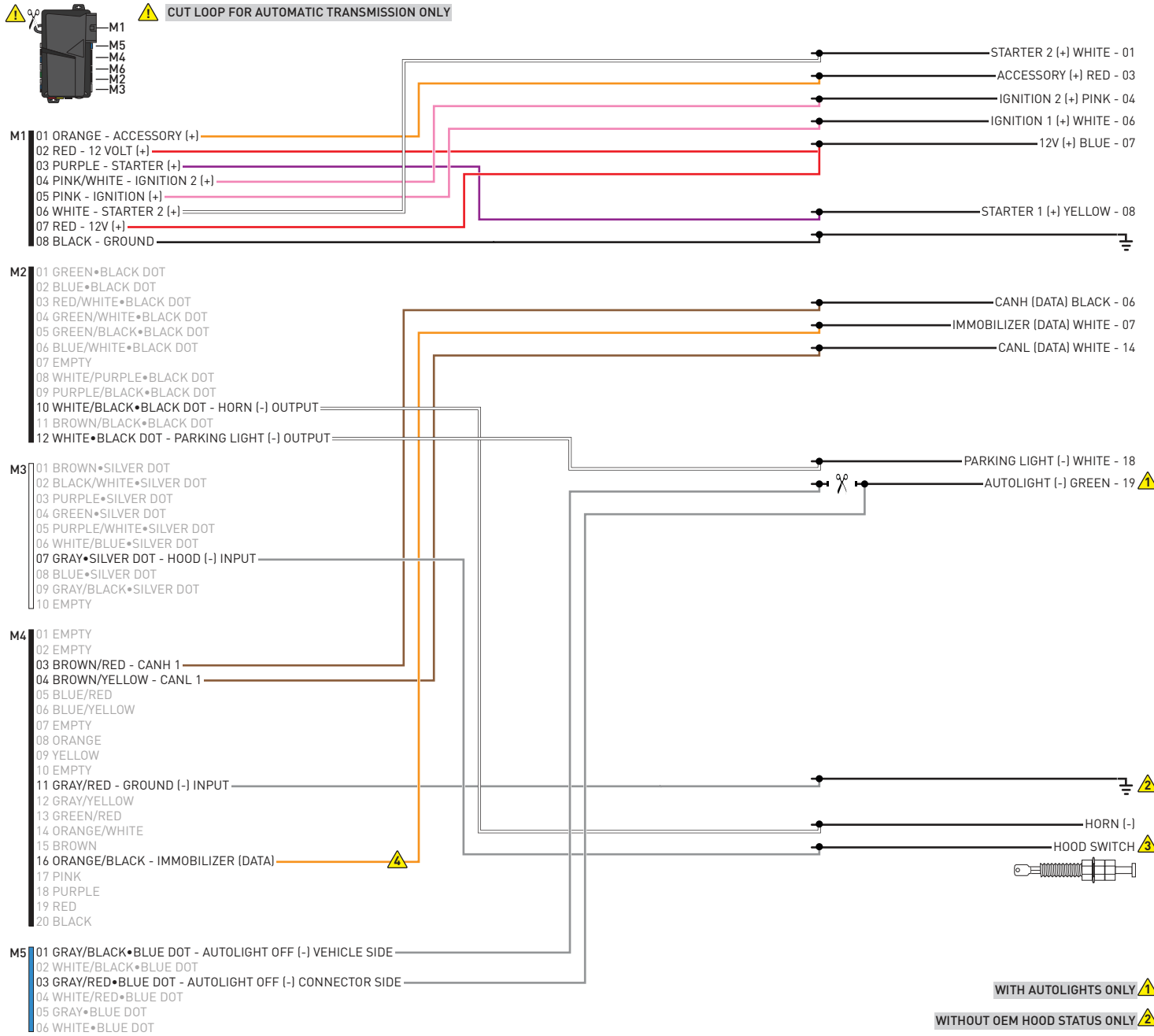

WITH AUTOLIGHTS ONLY ⚠

WITHOUT OEM HOOD STATUS ONLY ⚠

INSTALL THE SUPPLIED HOOD SWITCH IF THE VEHICLE IS NOT EQUIPPED WITH ONE. ⚠

CONNECT ORANGE/BLACK WIRE TO GROUND IF VEHICLE IS NOT EQUIPPED WITH IMMOBILIZER ⚠

01  Use the BLACK key only. DO NOT use the GRAY valet key.

02  Turn key to ON position.

03  Wait, LED 1 will turn solid GREEN for 2 seconds.

04  Turn key to OFF position.

05  START vehicle for 15 seconds.

06  Press and hold the brake pedal.

07  Press and release the module's programming button.

08  Release the brake pedal.

09  Wait, LED 2 will flash GREEN.

10  Module Programming Procedure completed.

>>



All vehicle doors must be closed and locked prior to remote start sequence.

01



Press unlock on OEM or aftermarket remote or request switch.

02



DO NOT PRESS BRAKE PEDAL. Set ignition to ON position. Wait 2 seconds for key validation.

03



Press and release BRAKE pedal.

04



Take over procedure completed.

>>



Failure to follow procedure will result in vehicle engine shutdown.

CHECKLIST - WITH AFTERMARKET KEYFOB

1	WARNING: Vehicle engine will start many times. Test in a well ventilated area.	9	Press the START/STOP button once [1x] on the aftermarket keyfob to shut down vehicle.
2	Close all vehicle doors, hood and trunk.		Question 7: Does the vehicle shut down?
3	Press the LOCK button once [1x] on the aftermarket keyfob.	<input type="checkbox"/>	YES: Go to next step.
	Question 1: Do the doors lock?	<input type="checkbox"/>	NO: Repeat step. If problem persists, press the brake pedal once [1x] to shut down the vehicle and call technical support.
<input type="checkbox"/>	YES: Go to next step.	10	RAP and auto light shutdown test
<input type="checkbox"/>	NO: Verify the remote programming, the RF connections and the wired door lock/unlock connections as illustrated in the wiring diagram, if applicable. Repeat the test and call technical support, if the problem persists.		Question 8: Did the radio, interior controls and headlights turn off within 60 seconds after remote start shutdown?
4	Press the UNLOCK button once [1x] on the aftermarket keyfob.	<input type="checkbox"/>	YES: Go to next step.
	Question 2: Do the doors unlock?	<input type="checkbox"/>	NO: Verify the RAP SHUTDOWN connections as illustrated in the wiring diagram. Repeat the test and call technical support if the problem persists.
<input type="checkbox"/>	YES: Go to next step.	11	Open hood.
<input type="checkbox"/>	NO: Verify the remote programming, the RF connections and the wired door lock/unlock connections as illustrated in the wiring diagram, if applicable. Repeat the test and call technical support, if the problem persists.	12	If not already installed, affix the mandatory orange warning sticker under the hood and proceed to next step.
5	Press the TRUNK release button once [1x] on the aftermarket keyfob if supported.	13	Press the START/STOP button once [1x] on the aftermarket keyfob to remote start vehicle.
	Question 3: Does the trunk or hatch open/unlock?		Question 9: Does the vehicle remote start?
<input type="checkbox"/>	YES: Close trunk or hatch and go to next step.	<input type="checkbox"/>	YES: The vehicle is not equipped with a factory hood pin. Install a mandatory aftermarket hood switch, then repeat the test.
<input type="checkbox"/>	NO: Verify the remote programming, the RF connections and the wired trunk/hatch connections as illustrated in the wiring diagram, if applicable. Repeat the test and call technical support, if the problem persists.	<input type="checkbox"/>	NO: Go to next step.
6	Press the AUX 1 button once [1x] on the aftermarket keyfob if supported.	14	Close hood.
	Question 4: Does the driver side sliding door open?	15	Enter vehicle and close the doors.
<input type="checkbox"/>	YES: Press the AUX 1 button once [1x] to close the driver sliding door and go to next step.	16	Press the START/STOP button once [1x] on the aftermarket keyfob to remote start vehicle.
<input type="checkbox"/>	NO: Verify the remote programming and the RF connections. Repeat the test and call technical support, if the problem persists.	17	Wait for the vehicle to start.
7	Press the AUX 2 button once [1x] on the aftermarket keyfob if supported.	18	Press brake pedal.
	Question 5: Does the passenger side sliding door open?		Question 10: Does the vehicle shut down?
<input type="checkbox"/>	YES: Press the AUX 2 button once [1x] to close the passenger sliding door and go to next step.	<input type="checkbox"/>	YES: Go to next step.
<input type="checkbox"/>	NO: Verify the remote programming and the RF connections. Repeat the test and call technical support, if the problem persists.	<input type="checkbox"/>	NO: The module does NOT detect the brake pedal signal. Press the START/STOP button once [1x] on the aftermarket keyfob to shut down vehicle, check connection as illustrated in the wiring diagram, if applicable, and call technical support.
8	Press the START/STOP button once [1x] on the aftermarket keyfob to remote start vehicle.	19	Exit vehicle.
	Question 6: Does the vehicle remote start?	20	Installation checklist completed.
<input type="checkbox"/>	YES: Go to next step.		
<input type="checkbox"/>	NO: Verify the remote programming, the RF connections and check the remote start error codes. Repeat the test and call technical support, if the problem persists.		

CHECKLIST - WITH OEM KEYFOB

1	WARNING: Vehicle engine will start many times. Test in a well ventilated area.
2	Close all vehicle doors, hood and trunk.
3	Press LOCK button three times [3x] rapidly on the OEM keyfob to remote start vehicle.
	Question 1: Does the vehicle remote start?
<input type="checkbox"/>	YES: Go to next step.
<input type="checkbox"/>	NO: The module doesn't detect OEM remote lock button from the vehicle communication network. Check all connections, repeat the test and call technical support, if the problem persists.
4	Press LOCK button three times [3x] rapidly on the OEM keyfob to shut down vehicle.
	Question 2: Does the vehicle shut down?
<input type="checkbox"/>	YES: Go to next step.
<input type="checkbox"/>	NO: Repeat step. If the problem persists, press on the brake pedal once [1x] to shut down the vehicle and call technical support.
5	RAP Shutdown test
	Question 3: Did the radio, interior controls, and headlights turn off within 60 seconds after remote start shutdown?
<input type="checkbox"/>	YES: Go to next step.
<input type="checkbox"/>	NO: Verify the RAP SHUTDOWN connections as illustrated in the wiring diagram. Repeat the test and call technical support, if the problem persists.
6	Open hood.
7	If not already installed, affix the mandatory orange warning sticker under the hood and proceed to next step.
8	Press LOCK button three times [3x] rapidly on the OEM keyfob to remote start vehicle.
	Question 4: Does the vehicle remote start?
<input type="checkbox"/>	YES: The vehicle is not equipped with a factory hood pin. Install a mandatory aftermarket hood switch, then repeat the test.
<input type="checkbox"/>	NO: Go to next step.
9	Close hood.
10	Enter vehicle and close the doors.
11	Press LOCK button three times [3x] rapidly on the OEM keyfob to remote start vehicle.
12	Wait for the vehicle to start.
13	Press brake pedal.
	Question 5: Does the vehicle shut down?
<input type="checkbox"/>	YES: Go to next step.
<input type="checkbox"/>	NO: The module does NOT detect the brake pedal signal. Press LOCK button three times [3x] rapidly on the OEM keyfob to shut down, check the brake connection as illustrated in the wiring diagram, if applicable, and call technical support.
14	Exit vehicle.
15	Installation checklist completed.

COMPUSTAR®

INSTALL GUIDE

2011-2014 TOYOTA SEQUOIA 80-BIT STD KEY AT



DOCUMENT NUMBER

REVISION DATE

20180926

FIRMWARE

COM-RSA-TL5-[RS1B-DC3]

HARDWARE

RS1B-DC3

ACCESSORIES

ATTENTION: TO COMPLETE THIS INSTALLATION SOME ACCESSORIES MAY BE REQUIRED. VISIT OUR WEBSITE TO SEE ALL THE REQUIRED ACCESSORIES FOR YOUR VEHICLE.

TERMS OF USE

Automotive Data Solutions Inc. ("ADS") products are strictly intended for installation by Certified Technicians who are employed by a registered business specialized in the installation of automotive aftermarket electronics products. Prior to beginning installation of an ADS product in a vehicle, it is the Certified Technician's responsibility to review the most current Product Guide, Install Guide and vehicle-specific notes available in Weblink®. ADS is not responsible for any damages whatsoever, including but not limited to any consequential damages, incidental damages, damages for loss of time, loss of earnings, loss of profit, commercial loss, loss of economic opportunity and the like that may or may not have resulted from the use, misuse, improper installation or operation of its products. ADS reserves itself the right to suspend any Weblink® account without notice and decline to offer technical support to non-Certified Technicians, non-compliant Certified Technicians or end users.

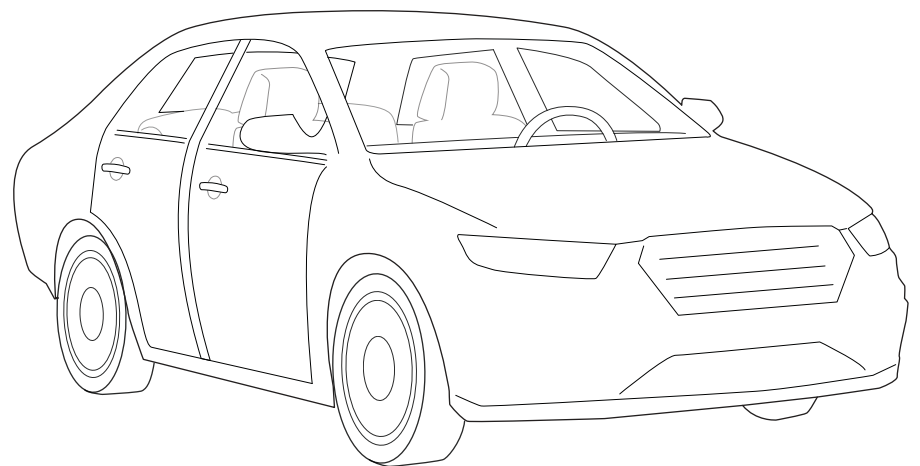
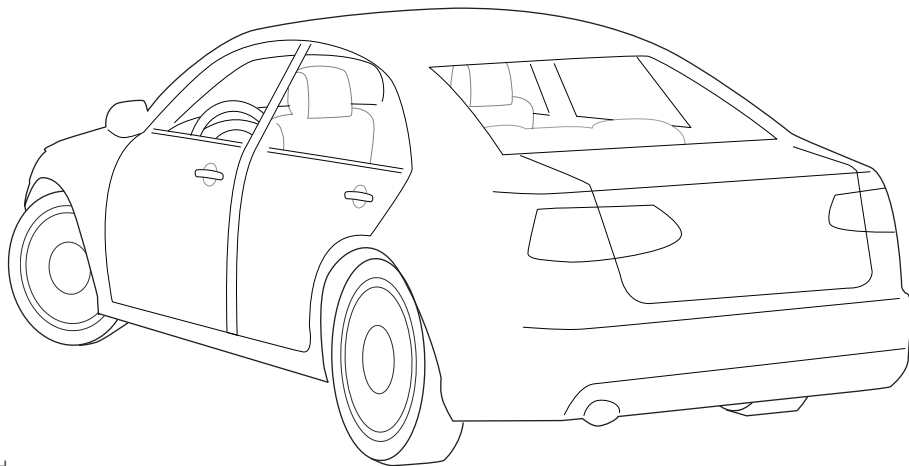
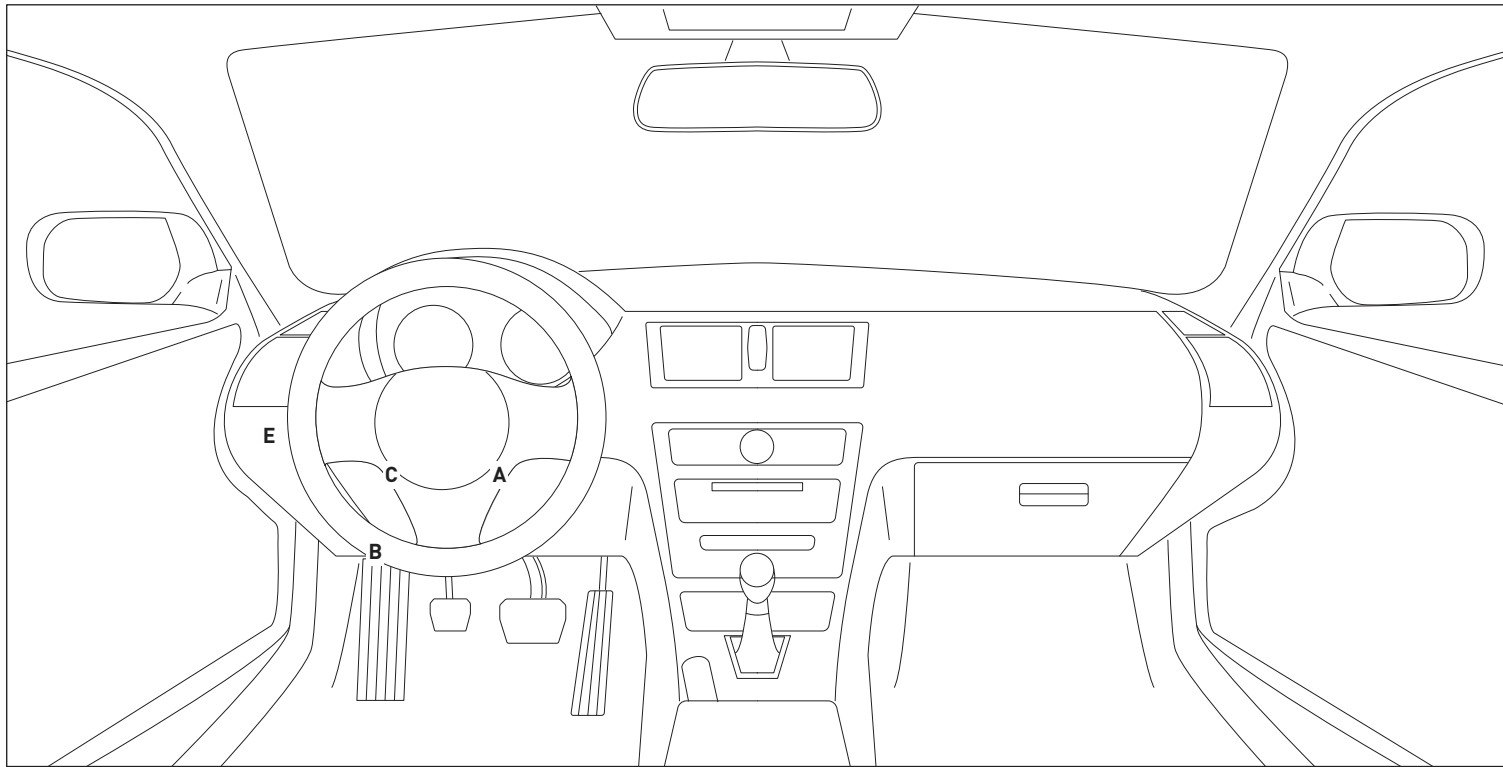

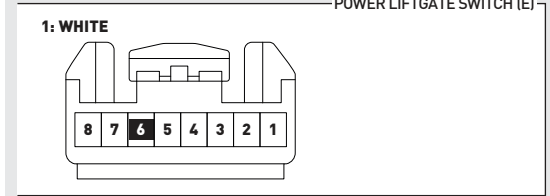
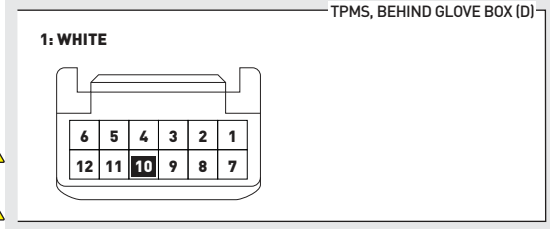
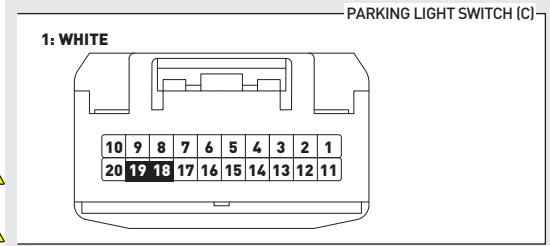
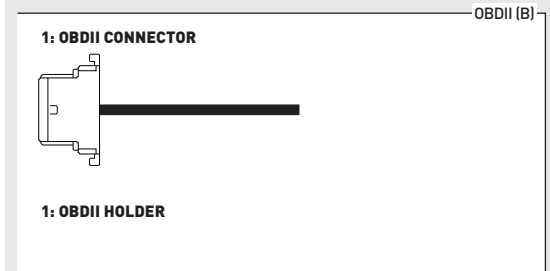
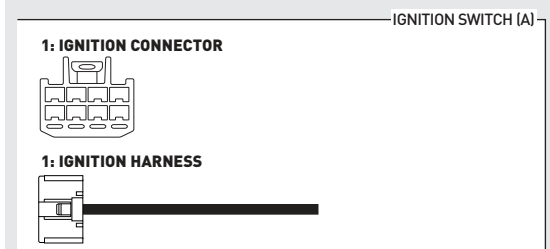
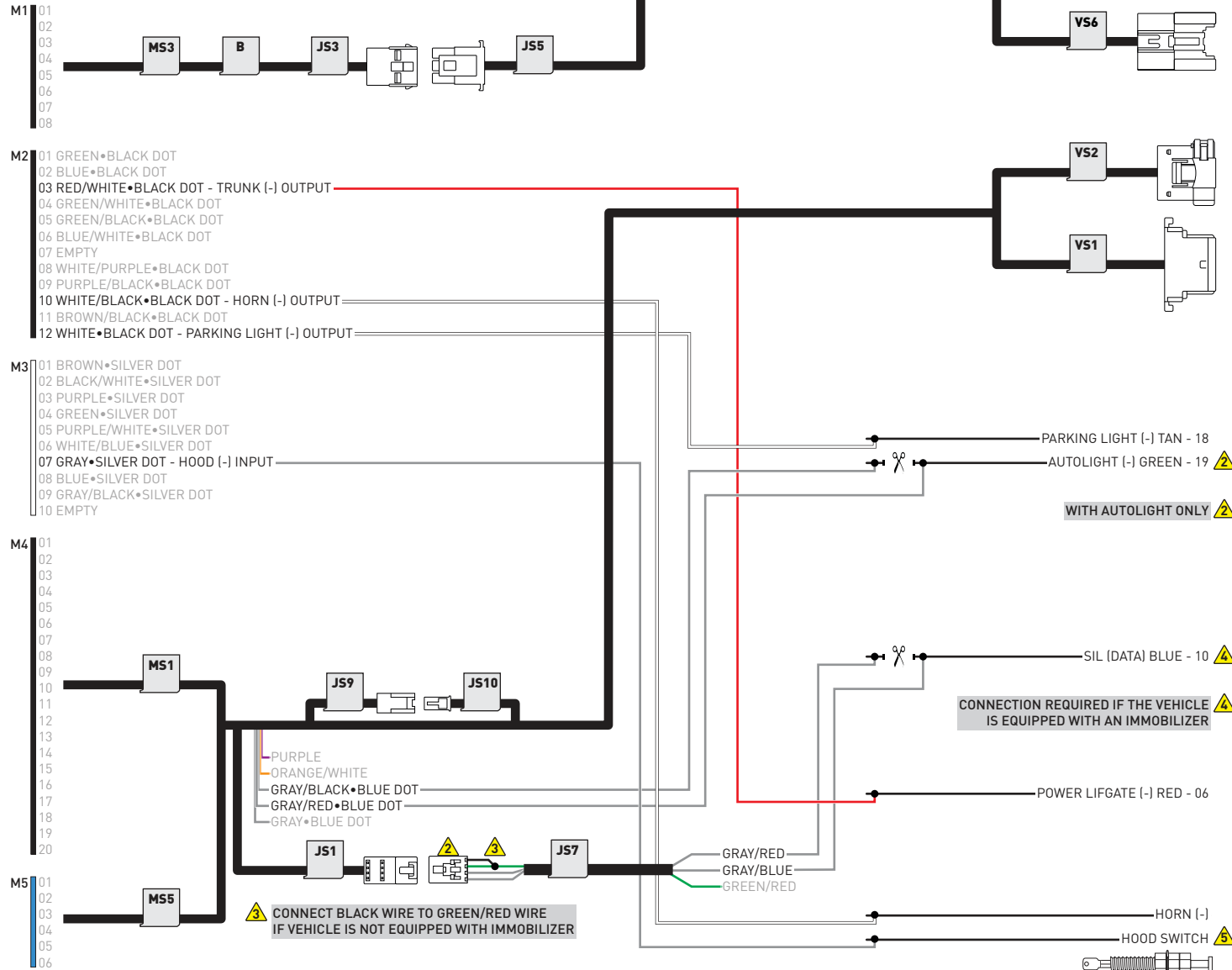
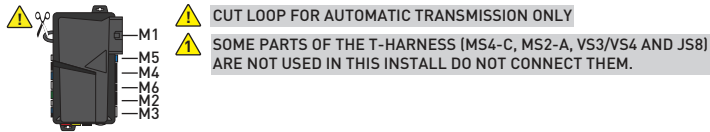

3 CONNECT BLACK WIRE TO GREEN/RED WIRE IF VEHICLE IS NOT EQUIPPED WITH IMMOBILIZER

5 IF NOT EQUIPPED WITH AN OEM HOOD PIN: - INSTALL THE SUPPLIED HOOD SWITCH. - CHANGE REMOTE STARTER INPUT CONFIGURATION (MENU #7) "4- HOOD INPUT SOURCE" TO "1- ANALOG".

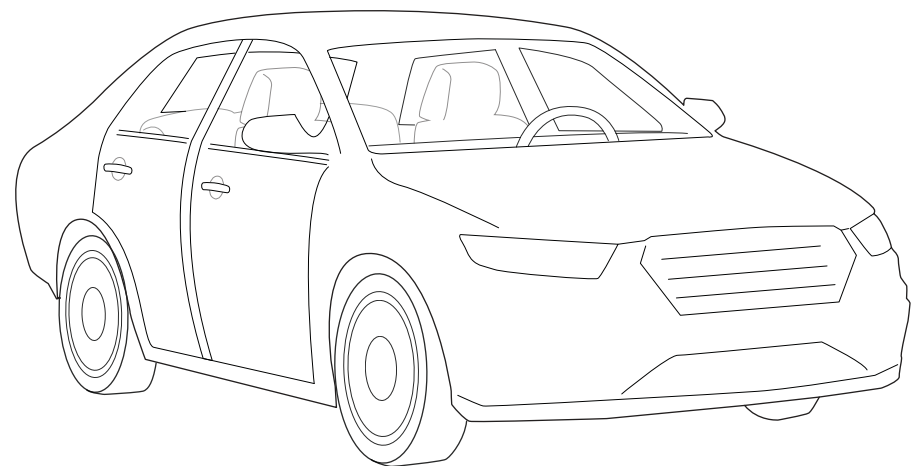
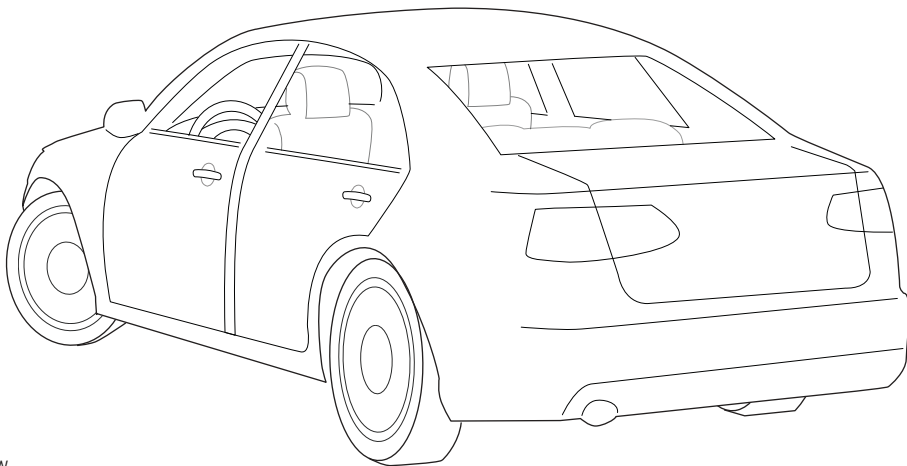
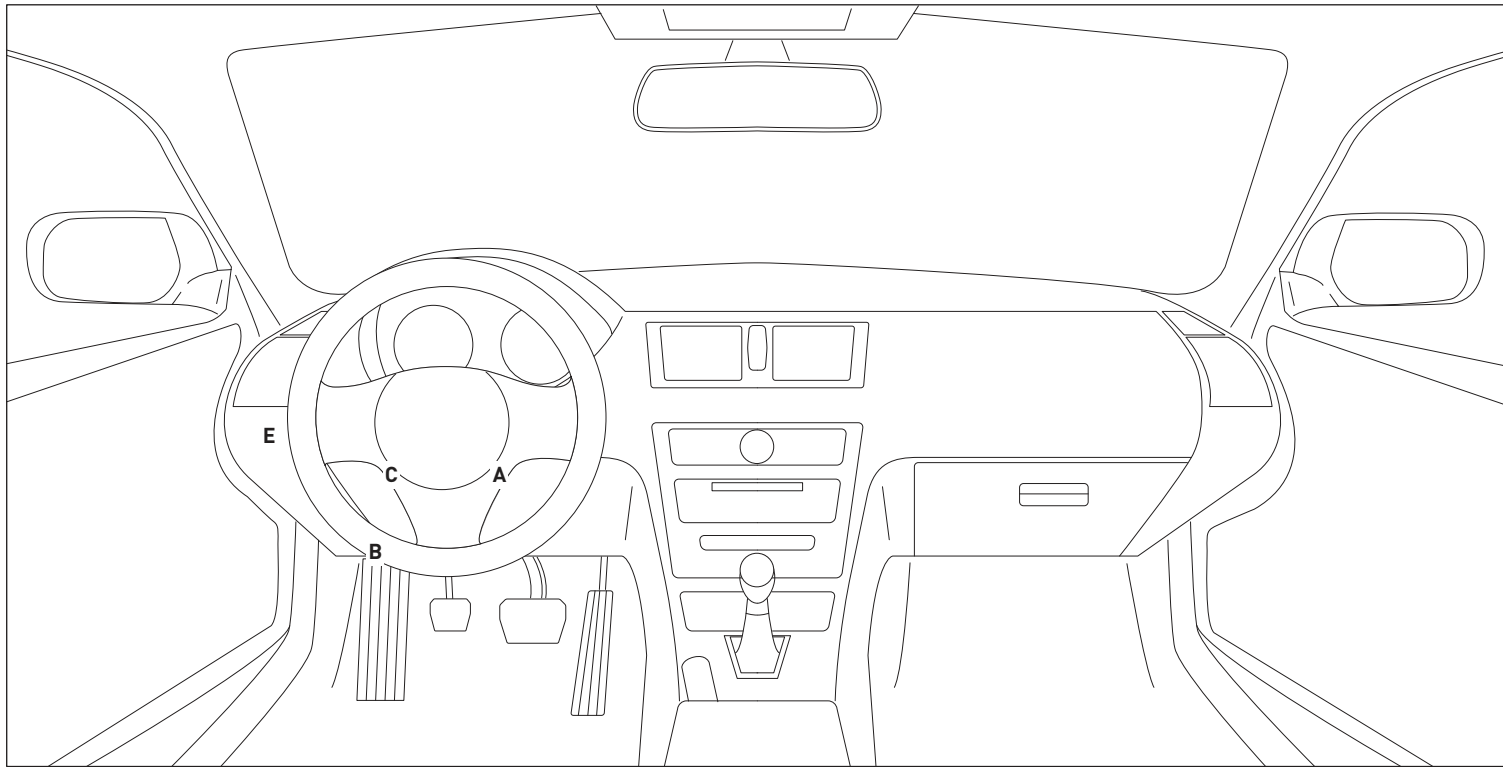

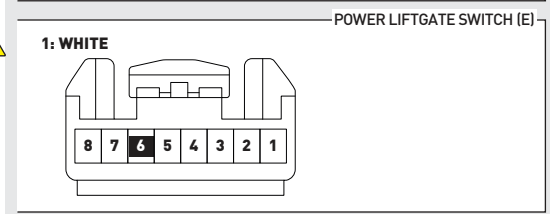
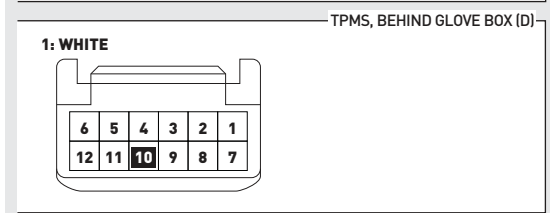
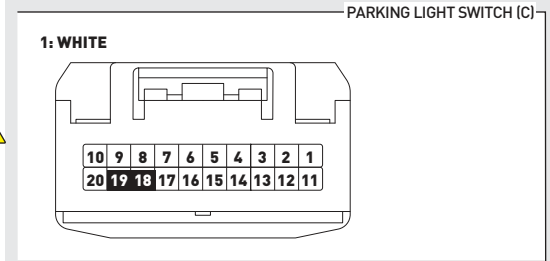
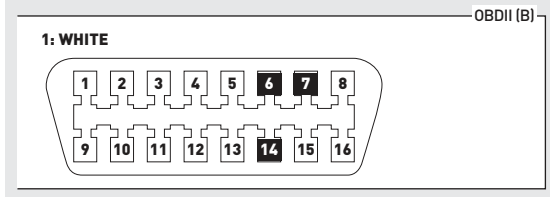
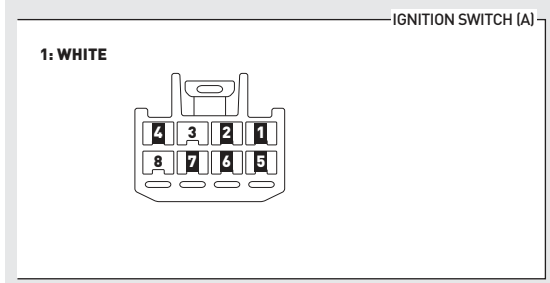
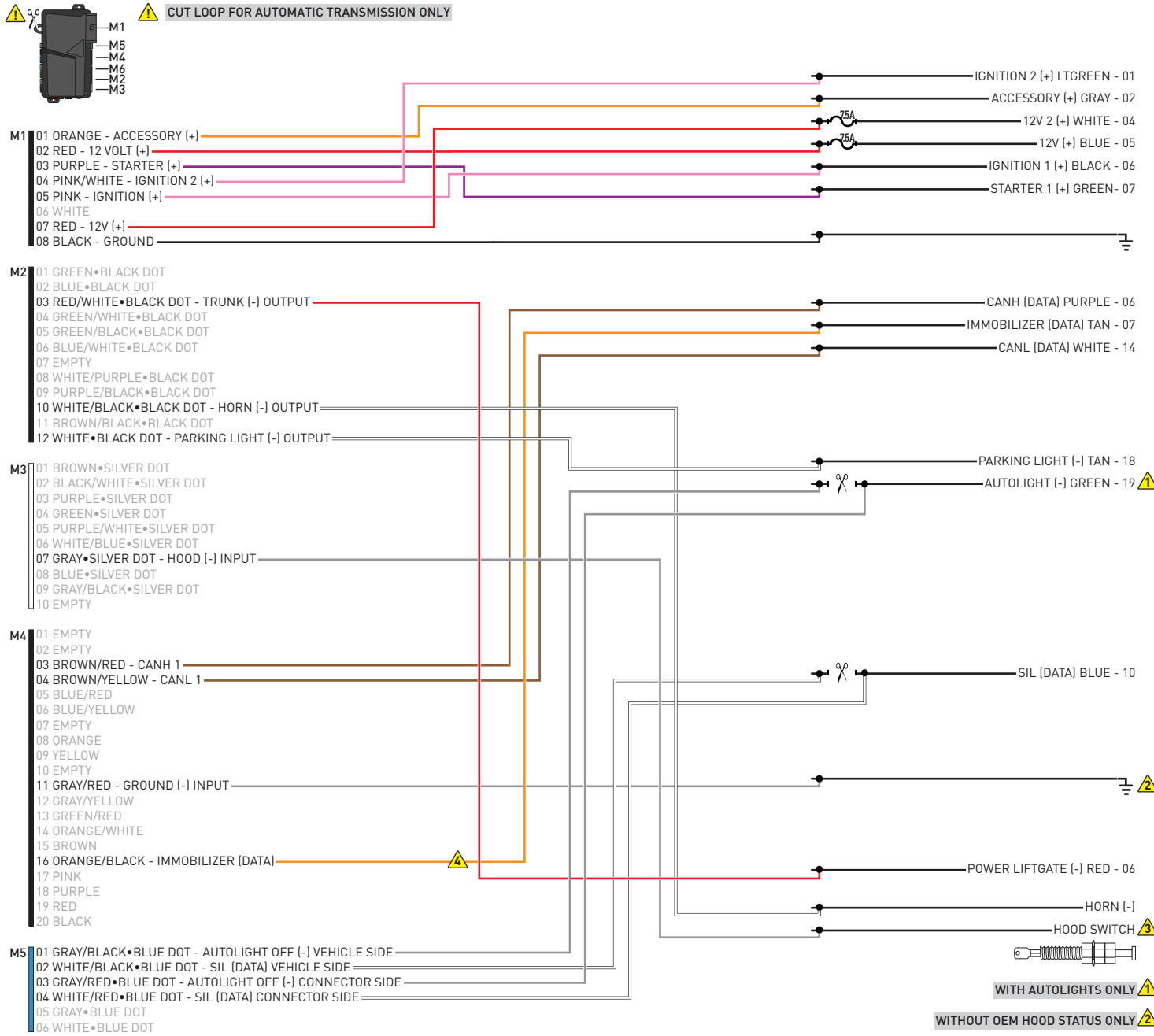

INSTALL THE SUPPLIED HOOD SWITCH IF THE VEHICLE IS NOT EQUIPPED WITH ONE. ⚠

CONNECT ORANGE/BLACK WIRE TO GROUND IF VEHICLE IS NOT EQUIPPED WITH IMMOBILIZER ⚠

WITH AUTOLIGHTS ONLY ⚠

WITHOUT OEM HOOD STATUS ONLY ⚠

01  Use the BLACK key only. DO NOT use the GRAY valet key.

02  Turn key to ON position.

03  Wait, LED 1 will turn solid GREEN for 2 seconds.

04  Turn key to OFF position.

05  START vehicle for 15 seconds.

06  Press and hold the brake pedal.

07  Press and release the module's programming button.

08  Release the brake pedal.

09  Wait, LED 2 will flash GREEN.

10  Module Programming Procedure completed.

>>



All vehicle doors must be closed and locked prior to remote start sequence.

01



Press unlock on OEM or aftermarket remote or request switch.

02



DO NOT PRESS BRAKE PEDAL. Set ignition to ON position. Wait 2 seconds for key validation.

03



Press and release BRAKE pedal.

04



Take over procedure completed.

>>



Failure to follow procedure will result in vehicle engine shutdown.

CHECKLIST - WITH AFTERMARKET KEYFOB

1	WARNING: Vehicle engine will start many times. Test in a well ventilated area.
2	Close all vehicle doors, hood and trunk.
3	Press the LOCK button once [1x] on the aftermarket keyfob.
	Question 1: Do the doors lock?
<input type="checkbox"/>	YES: Go to next step.
<input type="checkbox"/>	NO: Verify the remote programming, the RF connections and the wired door lock/unlock connections as illustrated in the wiring diagram, if applicable. Repeat the test and call technical support, if the problem persists.
4	Press the UNLOCK button once [1x] on the aftermarket keyfob.
	Question 2: Do the doors unlock?
<input type="checkbox"/>	YES: Go to next step.
<input type="checkbox"/>	NO: Verify the remote programming, the RF connections and the wired door lock/unlock connections as illustrated in the wiring diagram, if applicable. Repeat the test and call technical support, if the problem persists.
5	Press the TRUNK release button once [1x] on the aftermarket keyfob if supported.
	Question 3: Does the trunk or hatch open/unlock?
<input type="checkbox"/>	YES: Close trunk or hatch and go to next step.
<input type="checkbox"/>	NO: Verify the remote programming, the RF connections and the wired trunk/hatch connections as illustrated in the wiring diagram, if applicable. Repeat the test and call technical support, if the problem persists.
6	Press the AUX 1 button once [1x] on the aftermarket keyfob if supported.
	Question 4: Does the driver side sliding door open?
<input type="checkbox"/>	YES: Press the AUX 1 button once [1x] to close the driver sliding door and go to next step.
<input type="checkbox"/>	NO: Verify the remote programming and the RF connections. Repeat the test and call technical support, if the problem persists.
7	Press the AUX 2 button once [1x] on the aftermarket keyfob if supported.
	Question 5: Does the passenger side sliding door open?
<input type="checkbox"/>	YES: Press the AUX 2 button once [1x] to close the passenger sliding door and go to next step.
<input type="checkbox"/>	NO: Verify the remote programming and the RF connections. Repeat the test and call technical support, if the problem persists.
8	Press the START/STOP button once [1x] on the aftermarket keyfob to remote start vehicle.
	Question 6: Does the vehicle remote start?
<input type="checkbox"/>	YES: Go to next step.
<input type="checkbox"/>	NO: Verify the remote programming, the RF connections and check the remote start error codes. Repeat the test and call technical support, if the problem persists.

9	Press the START/STOP button once [1x] on the aftermarket keyfob to shut down vehicle.
	Question 7: Does the vehicle shut down?
<input type="checkbox"/>	YES: Go to next step.
<input type="checkbox"/>	NO: Repeat step. If problem persists, press the brake pedal once [1x] to shut down the vehicle and call technical support.
10	RAP and auto light shutdown test
	Question 8: Did the radio, interior controls and headlights turn off within 60 seconds after remote start shutdown?
<input type="checkbox"/>	YES: Go to next step.
<input type="checkbox"/>	NO: Verify the RAP SHUTDOWN connections as illustrated in the wiring diagram. Repeat the test and call technical support if the problem persists.
11	Open hood.
12	If not already installed, affix the mandatory orange warning sticker under the hood and proceed to next step.
13	Press the START/STOP button once [1x] on the aftermarket keyfob to remote start vehicle.
	Question 9: Does the vehicle remote start?
<input type="checkbox"/>	YES: The vehicle is not equipped with a factory hood pin. Install a mandatory aftermarket hood switch, then repeat the test.
<input type="checkbox"/>	NO: Go to next step.
14	Close hood.
15	Enter vehicle and close the doors.
16	Press the START/STOP button once [1x] on the aftermarket keyfob to remote start vehicle.
17	Wait for the vehicle to start.
18	Press brake pedal.
	Question 10: Does the vehicle shut down?
<input type="checkbox"/>	YES: Go to next step.
<input type="checkbox"/>	NO: The module does NOT detect the brake pedal signal. Press the START/STOP button once [1x] on the aftermarket keyfob to shut down vehicle, check connection as illustrated in the wiring diagram, if applicable, and call technical support.
19	Exit vehicle.
20	Installation checklist completed.

CHECKLIST - WITH OEM KEYFOB	
1	WARNING: Vehicle engine will start many times. Test in a well ventilated area.
2	Close all vehicle doors, hood and trunk.
3	Press LOCK button three times [3x] rapidly on the OEM keyfob to remote start vehicle.
	Question 1: Does the vehicle remote start?
<input type="checkbox"/>	YES: Go to next step.
<input type="checkbox"/>	NO: The module doesn't detect OEM remote lock button from the vehicle communication network. Check all connections, repeat the test and call technical support, if the problem persists.
4	Press LOCK button three times [3x] rapidly on the OEM keyfob to shut down vehicle.
	Question 2: Does the vehicle shut down?
<input type="checkbox"/>	YES: Go to next step.
<input type="checkbox"/>	NO: Repeat step. If the problem persists, press on the brake pedal once [1x] to shut down the vehicle and call technical support.
5	RAP Shutdown test
	Question 3: Did the radio, interior controls, and headlights turn off within 60 seconds after remote start shutdown?
<input type="checkbox"/>	YES: Go to next step.
<input type="checkbox"/>	NO: Verify the RAP SHUTDOWN connections as illustrated in the wiring diagram. Repeat the test and call technical support, if the problem persists.
6	Open hood.
7	If not already installed, affix the mandatory orange warning sticker under the hood and proceed to next step.
8	Press LOCK button three times [3x] rapidly on the OEM keyfob to remote start vehicle.
	Question 4: Does the vehicle remote start?
<input type="checkbox"/>	YES: The vehicle is not equipped with a factory hood pin. Install a mandatory aftermarket hood switch, then repeat the test.
<input type="checkbox"/>	NO: Go to next step.
9	Close hood.
10	Enter vehicle and close the doors.
11	Press LOCK button three times [3x] rapidly on the OEM keyfob to remote start vehicle.
12	Wait for the vehicle to start.
13	Press brake pedal.
	Question 5: Does the vehicle shut down?
<input type="checkbox"/>	YES: Go to next step.
<input type="checkbox"/>	NO: The module does NOT detect the brake pedal signal. Press LOCK button three times [3x] rapidly on the OEM keyfob to shut down, check the brake connection as illustrated in the wiring diagram, if applicable, and call technical support.
14	Exit vehicle.
15	Installation checklist completed.

COMPUSTAR®

INSTALL GUIDE

2011-2014 TOYOTA SIENNA 80-BIT STD KEY AT



DOCUMENT NUMBER

REVISION DATE

20180926

FIRMWARE

COM-RSA-TL5-[RS1B-DC3]

HARDWARE

RS1B-DC3

ACCESSORIES

ATTENTION: TO COMPLETE THIS INSTALLATION SOME ACCESSORIES MAY BE REQUIRED. VISIT OUR WEBSITE TO SEE ALL THE REQUIRED ACCESSORIES FOR YOUR VEHICLE.

TERMS OF USE

Automotive Data Solutions Inc. ("ADS") products are strictly intended for installation by Certified Technicians who are employed by a registered business specialized in the installation of automotive aftermarket electronics products. Prior to beginning installation of an ADS product in a vehicle, it is the Certified Technician's responsibility to review the most current Product Guide, Install Guide and vehicle-specific notes available in Weblink®. ADS is not responsible for any damages whatsoever, including but not limited to any consequential damages, incidental damages, damages for loss of time, loss of earnings, loss of profit, commercial loss, loss of economic opportunity and the like that may or may not have resulted from the use, misuse, improper installation or operation of its products. ADS reserves itself the right to suspend any Weblink® account without notice and decline to offer technical support to non-Certified Technicians, non-compliant Certified Technicians or end users.

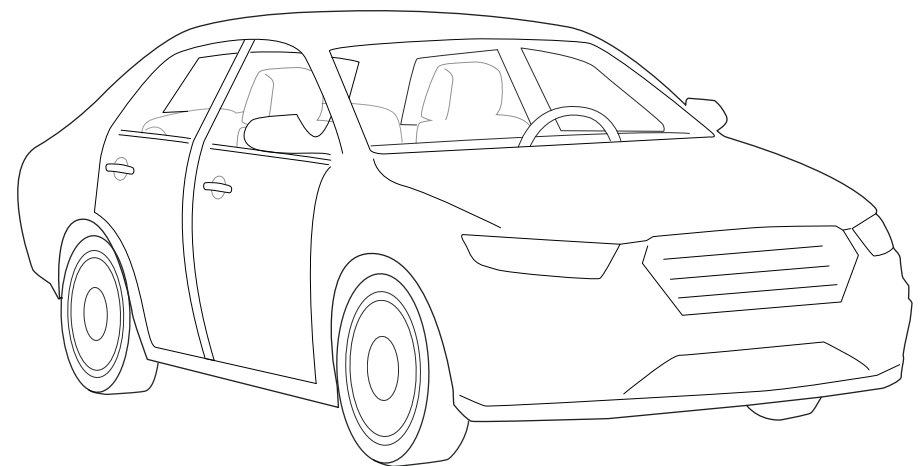
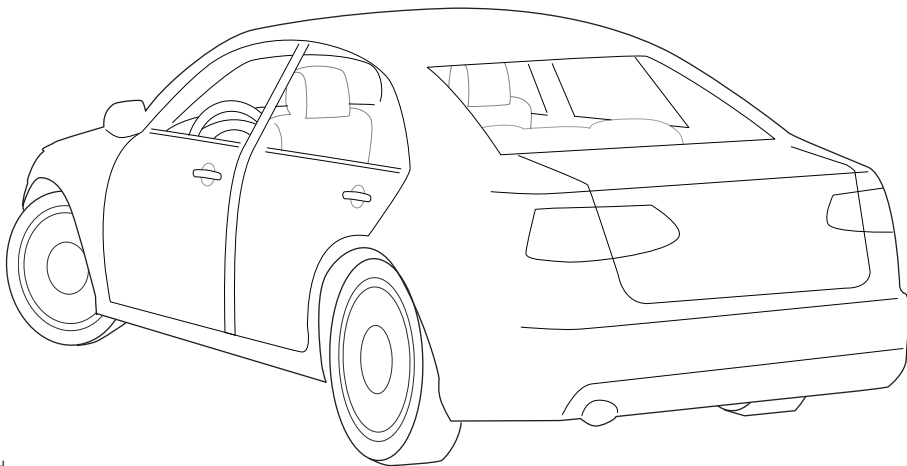
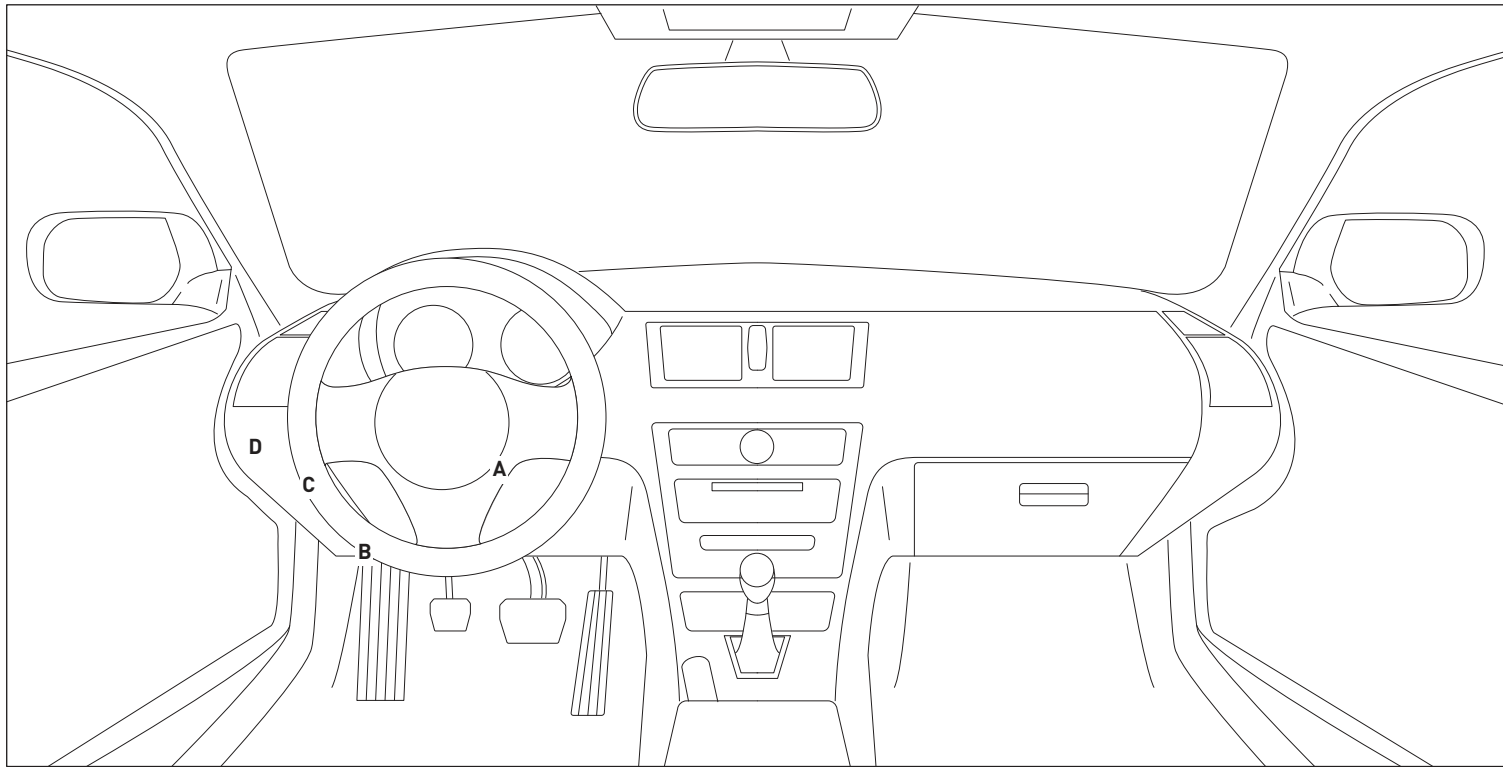

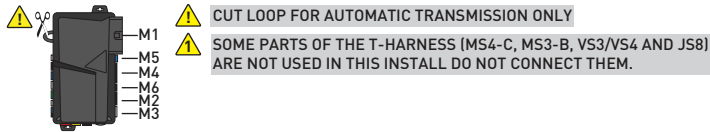

- M1**
- 01
 - 02
 - 03
 - 04
 - 05
 - 06
 - 07
 - 08

- M2**
- 01 GREEN•BLACK DOT
 - 02 BLUE•BLACK DOT
 - 03 RED/WHITE•BLACK DOT
 - 04 GREEN/WHITE•BLACK DOT
 - 05 GREEN/BLACK•BLACK DOT
 - 06 BLUE/WHITE•BLACK DOT
 - 07 EMPTY
 - 08 WHITE/PURPLE•BLACK DOT
 - 09 PURPLE/BLACK•BLACK DOT
 - 10 WHITE/BLACK•BLACK DOT - HORN (-) OUTPUT
 - 11 BROWN/BLACK•BLACK DOT
 - 12 WHITE•BLACK DOT - PARKING LIGHT (-) OUTPUT

- M3**
- 01 BROWN•SILVER DOT
 - 02 BLACK/WHITE•SILVER DOT
 - 03 PURPLE•SILVER DOT
 - 04 GREEN•SILVER DOT
 - 05 PURPLE/WHITE•SILVER DOT
 - 06 WHITE/BLUE•SILVER DOT
 - 07 GRAY•SILVER DOT - HOOD (-) INPUT
 - 08 BLUE•SILVER DOT
 - 09 GRAY/BLACK•SILVER DOT
 - 10 EMPTY

- M4**
- 01
 - 02
 - 03
 - 04
 - 05
 - 06
 - 07
 - 08
 - 09
 - 10
 - 11
 - 12
 - 13
 - 14
 - 15
 - 16
 - 17
 - 18
 - 19
 - 20

- M5**
- 01
 - 02
 - 03
 - 04
 - 05
 - 06

3 CONNECT BLACK WIRE TO GREEN/RED WIRE IF VEHICLE IS NOT EQUIPPED WITH IMMOBILIZER

IF NOT EQUIPPED WITH AN OEM HOOD PIN:
- INSTALL THE SUPPLIED HOOD SWITCH.
- CHANGE REMOTE STARTER INPUT CONFIGURATION (MENU #7) "4- HOOD INPUT SOURCE" TO "1- ANALOG".

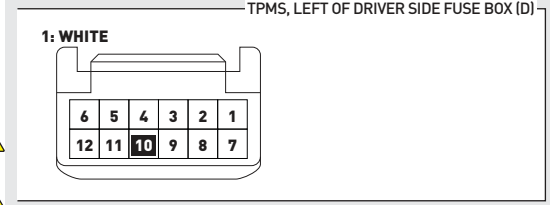
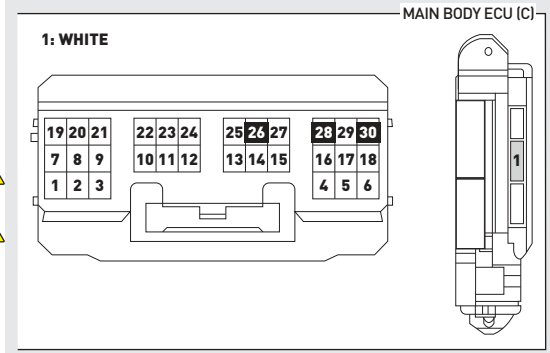
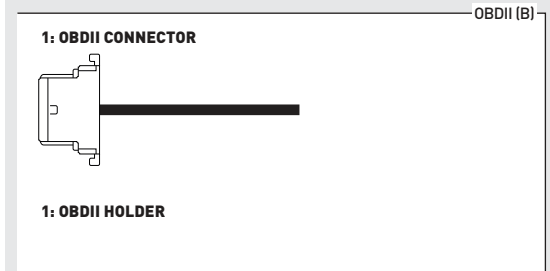
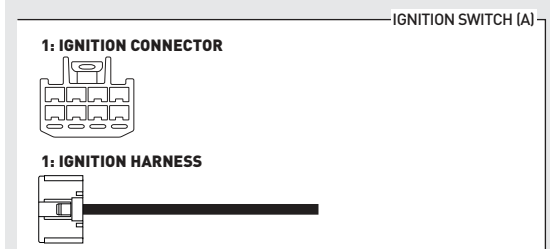
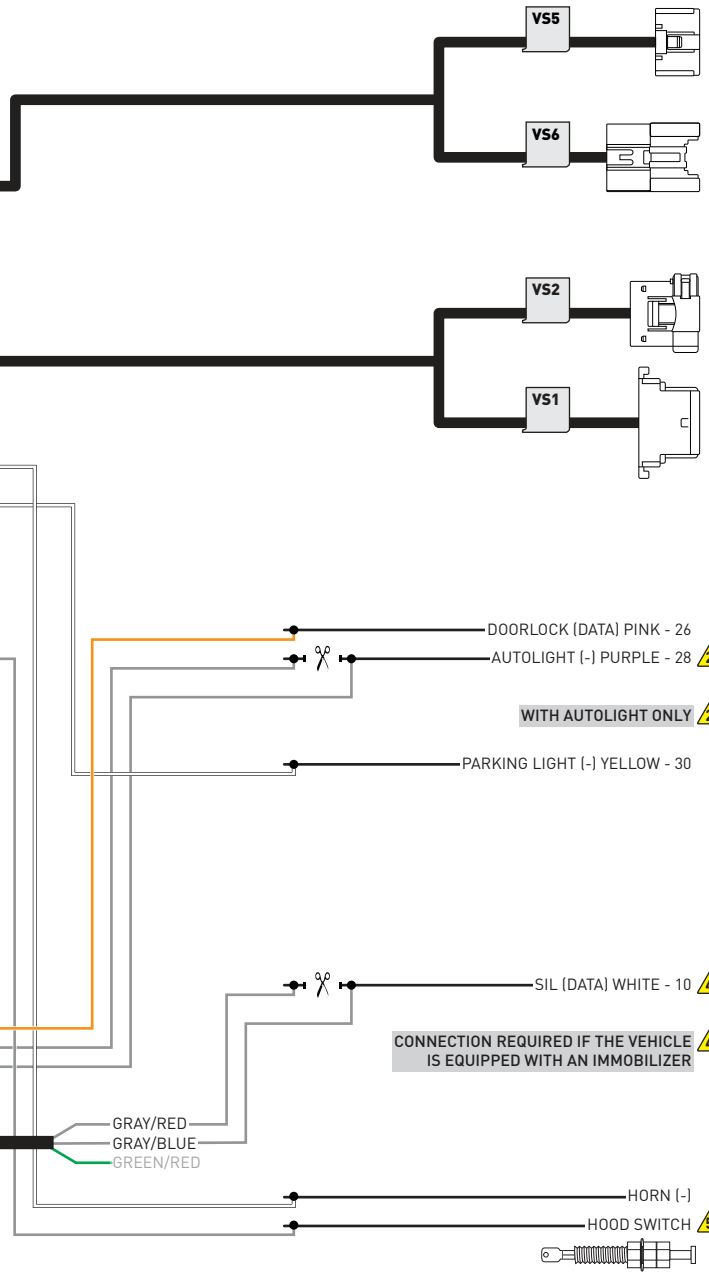

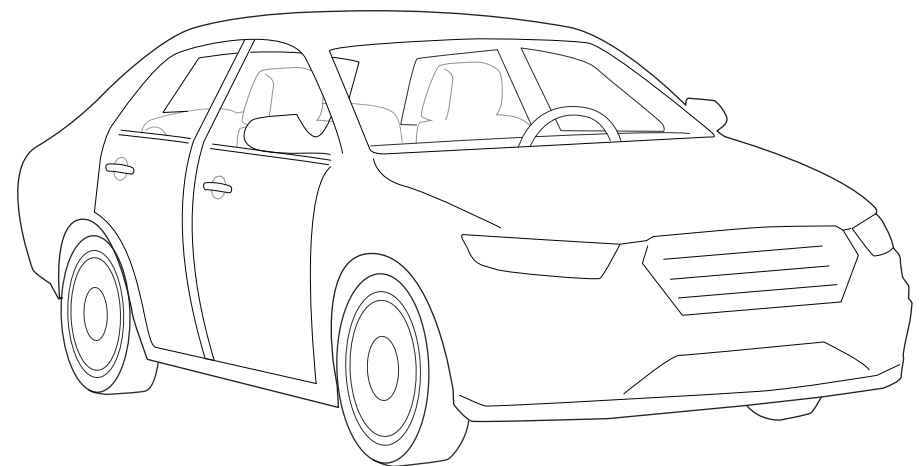
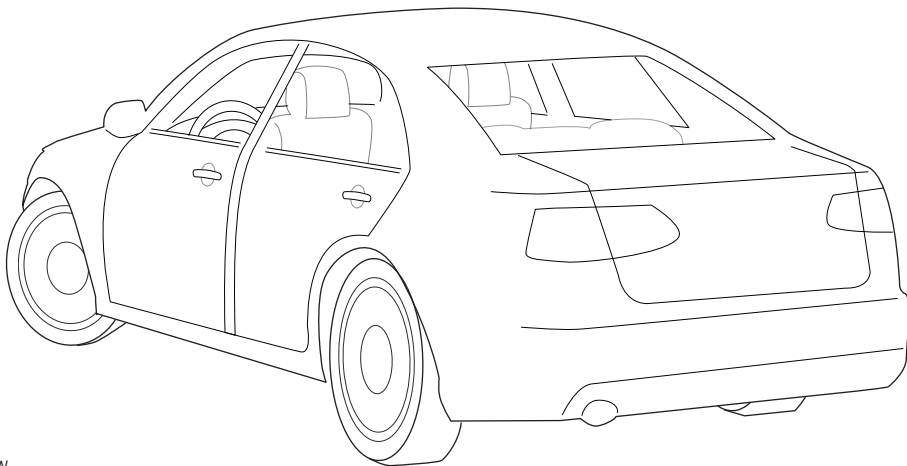
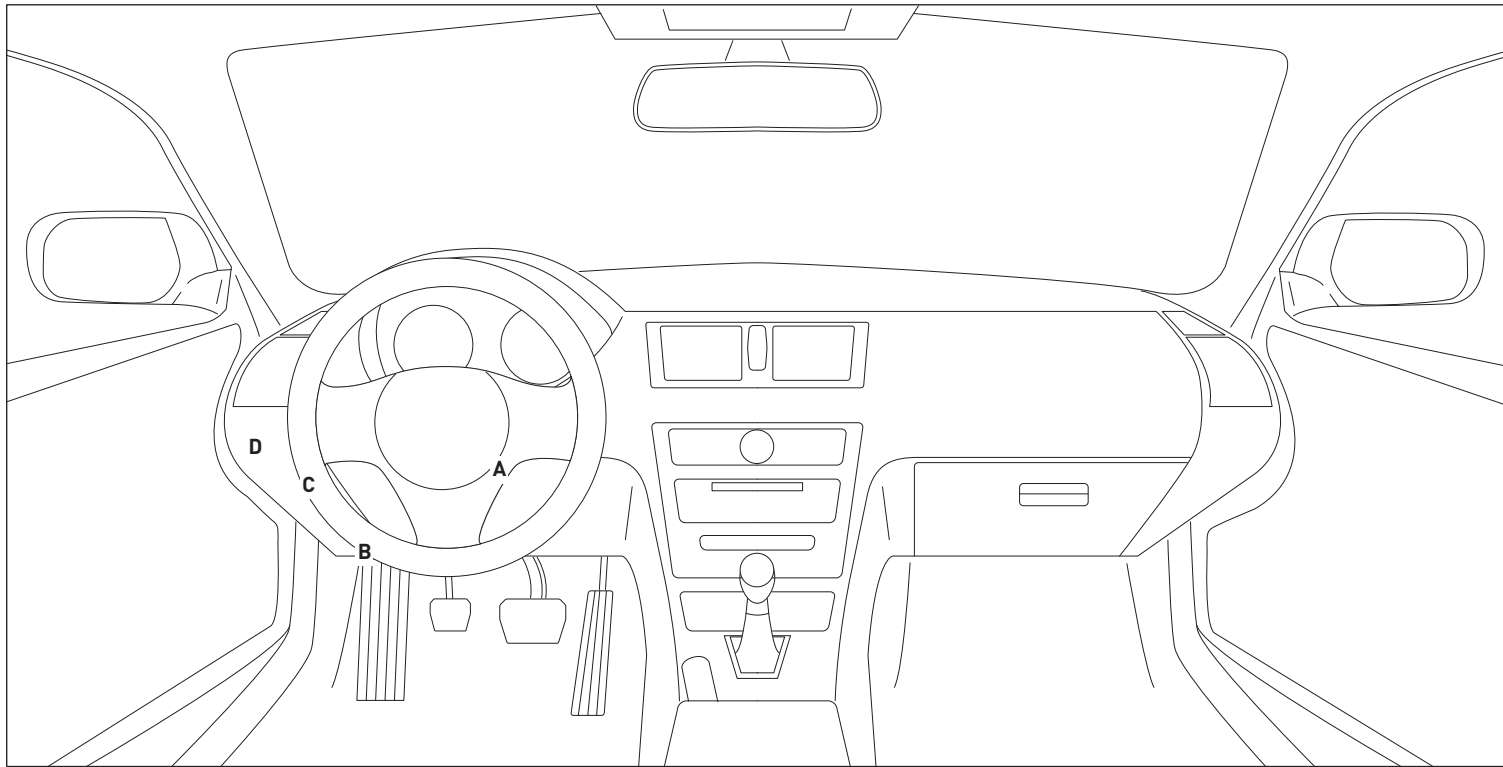

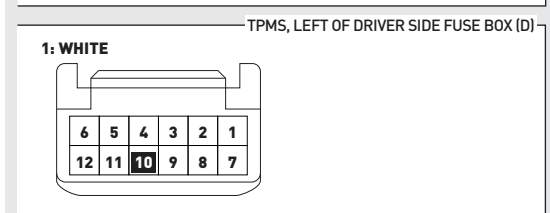
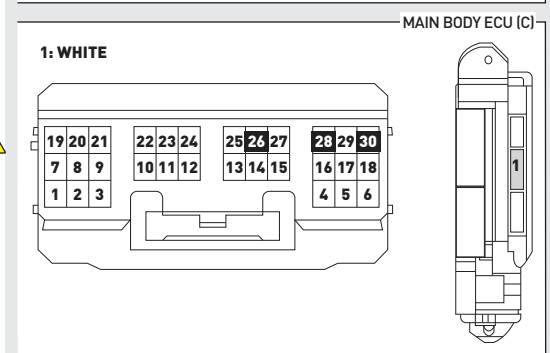
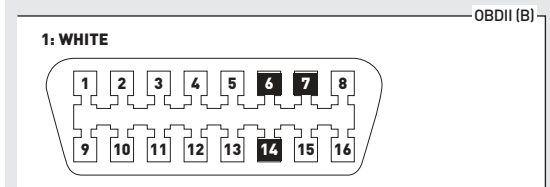
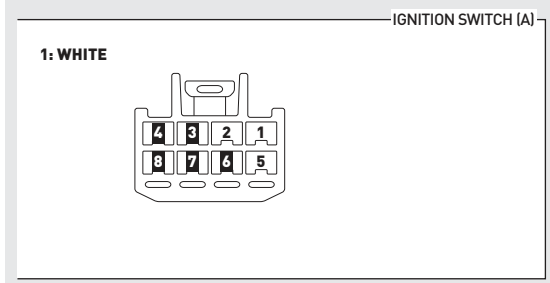
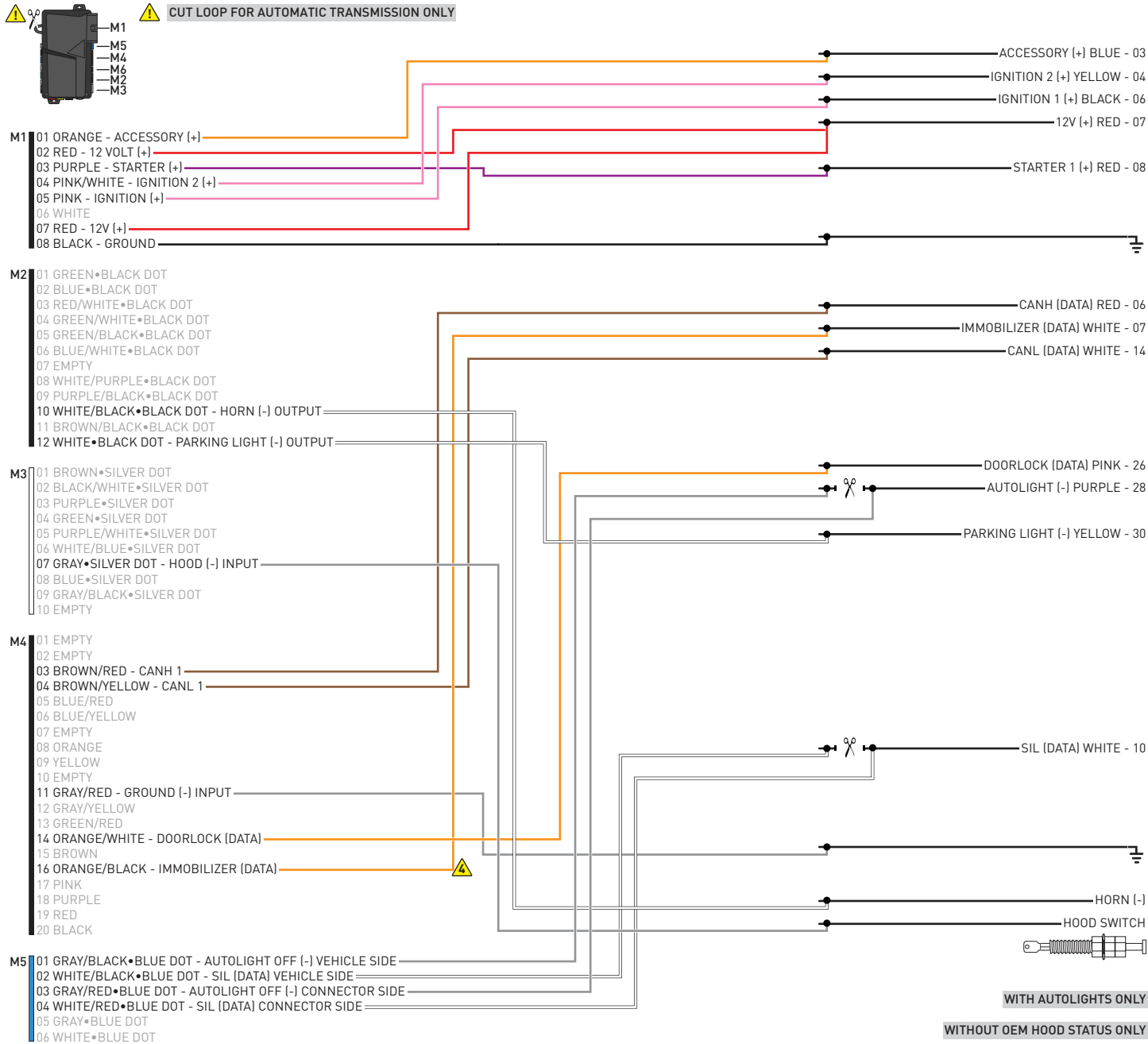

WITH AUTOLIGHTS ONLY ⚠

WITHOUT OEM HOOD STATUS ONLY ⚠

INSTALL THE SUPPLIED HOOD SWITCH IF THE VEHICLE IS NOT EQUIPPED WITH ONE. ⚠

CONNECT ORANGE/BLACK WIRE TO GROUND IF VEHICLE IS NOT EQUIPPED WITH IMMOBILIZER ⚠

01  Use the **BLACK** key only. **DO NOT** use the **GRAY** valet key.

02  Turn key to **ON** position.

03  Wait, LED 1 will turn solid **GREEN** for 2 seconds.

04  Turn key to **OFF** position.

05  **START** vehicle for 15 seconds.

06  Press and hold the brake pedal.

07  Press and release the module's programming button.

08  Release the brake pedal.

09  Wait, LED 2 will flash **GREEN**.

10  Module Programming Procedure completed.

>>



All vehicle doors must be closed and locked prior to remote start sequence.

01



Press unlock on OEM or aftermarket remote or request switch.

02



DO NOT PRESS BRAKE PEDAL. Set ignition to ON position. Wait 2 seconds for key validation.

03



Press and release BRAKE pedal.

04



Take over procedure completed.

>>



Failure to follow procedure will result in vehicle engine shutdown.

CHECKLIST - WITH AFTERMARKET KEYFOB

1	WARNING: Vehicle engine will start many times. Test in a well ventilated area.
2	Close all vehicle doors, hood and trunk.
3	Press the LOCK button once [1x] on the aftermarket keyfob.
	Question 1: Do the doors lock?
<input type="checkbox"/>	YES: Go to next step.
<input type="checkbox"/>	NO: Verify the remote programming, the RF connections and the wired door lock/unlock connections as illustrated in the wiring diagram, if applicable. Repeat the test and call technical support, if the problem persists.
4	Press the UNLOCK button once [1x] on the aftermarket keyfob.
	Question 2: Do the doors unlock?
<input type="checkbox"/>	YES: Go to next step.
<input type="checkbox"/>	NO: Verify the remote programming, the RF connections and the wired door lock/unlock connections as illustrated in the wiring diagram, if applicable. Repeat the test and call technical support, if the problem persists.
5	Press the TRUNK release button once [1x] on the aftermarket keyfob if supported.
	Question 3: Does the trunk or hatch open/unlock?
<input type="checkbox"/>	YES: Close trunk or hatch and go to next step.
<input type="checkbox"/>	NO: Verify the remote programming, the RF connections and the wired trunk/hatch connections as illustrated in the wiring diagram, if applicable. Repeat the test and call technical support, if the problem persists.
6	Press the AUX 1 button once [1x] on the aftermarket keyfob if supported.
	Question 4: Does the driver side sliding door open?
<input type="checkbox"/>	YES: Press the AUX 1 button once [1x] to close the driver sliding door and go to next step.
<input type="checkbox"/>	NO: Verify the remote programming and the RF connections. Repeat the test and call technical support, if the problem persists.
7	Press the AUX 2 button once [1x] on the aftermarket keyfob if supported.
	Question 5: Does the passenger side sliding door open?
<input type="checkbox"/>	YES: Press the AUX 2 button once [1x] to close the passenger sliding door and go to next step.
<input type="checkbox"/>	NO: Verify the remote programming and the RF connections. Repeat the test and call technical support, if the problem persists.
8	Press the START/STOP button once [1x] on the aftermarket keyfob to remote start vehicle.
	Question 6: Does the vehicle remote start?
<input type="checkbox"/>	YES: Go to next step.
<input type="checkbox"/>	NO: Verify the remote programming, the RF connections and check the remote start error codes. Repeat the test and call technical support, if the problem persists.

9	Press the START/STOP button once [1x] on the aftermarket keyfob to shut down vehicle.
	Question 7: Does the vehicle shut down?
<input type="checkbox"/>	YES: Go to next step.
<input type="checkbox"/>	NO: Repeat step. If problem persists, press the brake pedal once [1x] to shut down the vehicle and call technical support.
10	RAP and auto light shutdown test
	Question 8: Did the radio, interior controls and headlights turn off within 60 seconds after remote start shutdown?
<input type="checkbox"/>	YES: Go to next step.
<input type="checkbox"/>	NO: Verify the RAP SHUTDOWN connections as illustrated in the wiring diagram. Repeat the test and call technical support if the problem persists.
11	Open hood.
12	If not already installed, affix the mandatory orange warning sticker under the hood and proceed to next step.
13	Press the START/STOP button once [1x] on the aftermarket keyfob to remote start vehicle.
	Question 9: Does the vehicle remote start?
<input type="checkbox"/>	YES: The vehicle is not equipped with a factory hood pin. Install a mandatory aftermarket hood switch, then repeat the test.
<input type="checkbox"/>	NO: Go to next step.
14	Close hood.
15	Enter vehicle and close the doors.
16	Press the START/STOP button once [1x] on the aftermarket keyfob to remote start vehicle.
17	Wait for the vehicle to start.
18	Press brake pedal.
	Question 10: Does the vehicle shut down?
<input type="checkbox"/>	YES: Go to next step.
<input type="checkbox"/>	NO: The module does NOT detect the brake pedal signal. Press the START/STOP button once [1x] on the aftermarket keyfob to shut down vehicle, check connection as illustrated in the wiring diagram, if applicable, and call technical support.
19	Exit vehicle.
20	Installation checklist completed.

CHECKLIST - WITH OEM KEYFOB	
1	WARNING: Vehicle engine will start many times. Test in a well ventilated area.
2	Close all vehicle doors, hood and trunk.
3	Press LOCK button three times [3x] rapidly on the OEM keyfob to remote start vehicle.
	Question 1: Does the vehicle remote start?
<input type="checkbox"/>	YES: Go to next step.
<input type="checkbox"/>	NO: The module doesn't detect OEM remote lock button from the vehicle communication network. Check all connections, repeat the test and call technical support, if the problem persists.
4	Press LOCK button three times [3x] rapidly on the OEM keyfob to shut down vehicle.
	Question 2: Does the vehicle shut down?
<input type="checkbox"/>	YES: Go to next step.
<input type="checkbox"/>	NO: Repeat step. If the problem persists, press on the brake pedal once [1x] to shut down the vehicle and call technical support.
5	RAP Shutdown test
	Question 3: Did the radio, interior controls, and headlights turn off within 60 seconds after remote start shutdown?
<input type="checkbox"/>	YES: Go to next step.
<input type="checkbox"/>	NO: Verify the RAP SHUTDOWN connections as illustrated in the wiring diagram. Repeat the test and call technical support, if the problem persists.
6	Open hood.
7	If not already installed, affix the mandatory orange warning sticker under the hood and proceed to next step.
8	Press LOCK button three times [3x] rapidly on the OEM keyfob to remote start vehicle.
	Question 4: Does the vehicle remote start?
<input type="checkbox"/>	YES: The vehicle is not equipped with a factory hood pin. Install a mandatory aftermarket hood switch, then repeat the test.
<input type="checkbox"/>	NO: Go to next step.
9	Close hood.
10	Enter vehicle and close the doors.
11	Press LOCK button three times [3x] rapidly on the OEM keyfob to remote start vehicle.
12	Wait for the vehicle to start.
13	Press brake pedal.
	Question 5: Does the vehicle shut down?
<input type="checkbox"/>	YES: Go to next step.
<input type="checkbox"/>	NO: The module does NOT detect the brake pedal signal. Press LOCK button three times [3x] rapidly on the OEM keyfob to shut down, check the brake connection as illustrated in the wiring diagram, if applicable, and call technical support.
14	Exit vehicle.
15	Installation checklist completed.

COMPUSTAR®

INSTALL GUIDE

2011-2015 TOYOTA TACOMA 80-BIT STD KEY AT



DOCUMENT NUMBER

REVISION DATE

20180926

FIRMWARE

COM-RSA-TL5-[RS1B-DC3]

HARDWARE

RS1B-DC3

ACCESSORIES

ATTENTION: TO COMPLETE THIS INSTALLATION SOME ACCESSORIES MAY BE REQUIRED. VISIT OUR WEBSITE TO SEE ALL THE REQUIRED ACCESSORIES FOR YOUR VEHICLE.

TERMS OF USE

Automotive Data Solutions Inc. ("ADS") products are strictly intended for installation by Certified Technicians who are employed by a registered business specialized in the installation of automotive aftermarket electronics products. Prior to beginning installation of an ADS product in a vehicle, it is the Certified Technician's responsibility to review the most current Product Guide, Install Guide and vehicle-specific notes available in Weblink®. ADS is not responsible for any damages whatsoever, including but not limited to any consequential damages, incidental damages, damages for loss of time, loss of earnings, loss of profit, commercial loss, loss of economic opportunity and the like that may or may not have resulted from the use, misuse, improper installation or operation of its products. ADS reserves itself the right to suspend any Weblink® account without notice and decline to offer technical support to non-Certified Technicians, non-compliant Certified Technicians or end users.

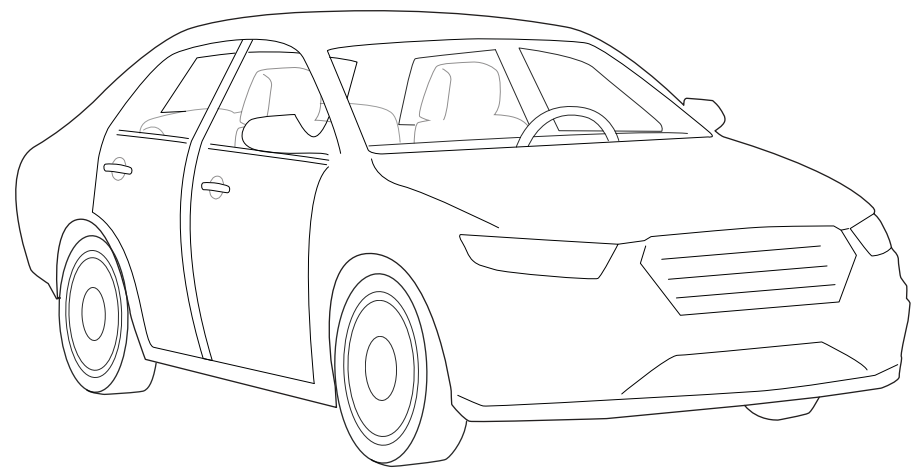
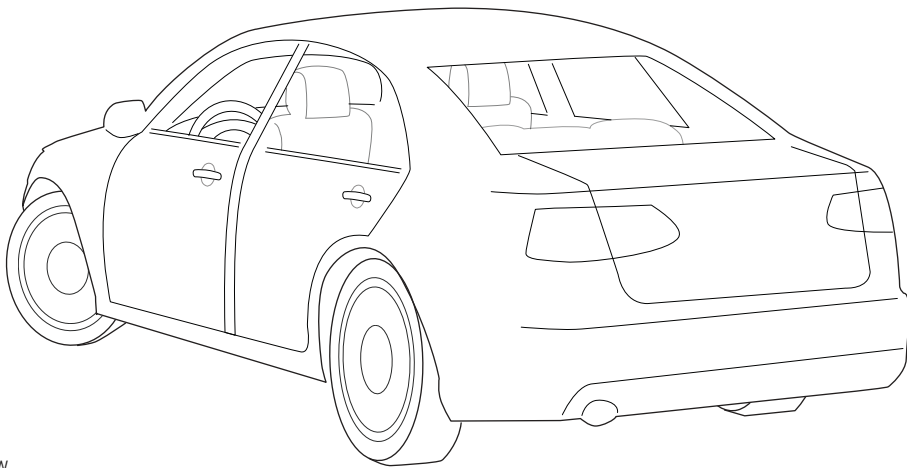
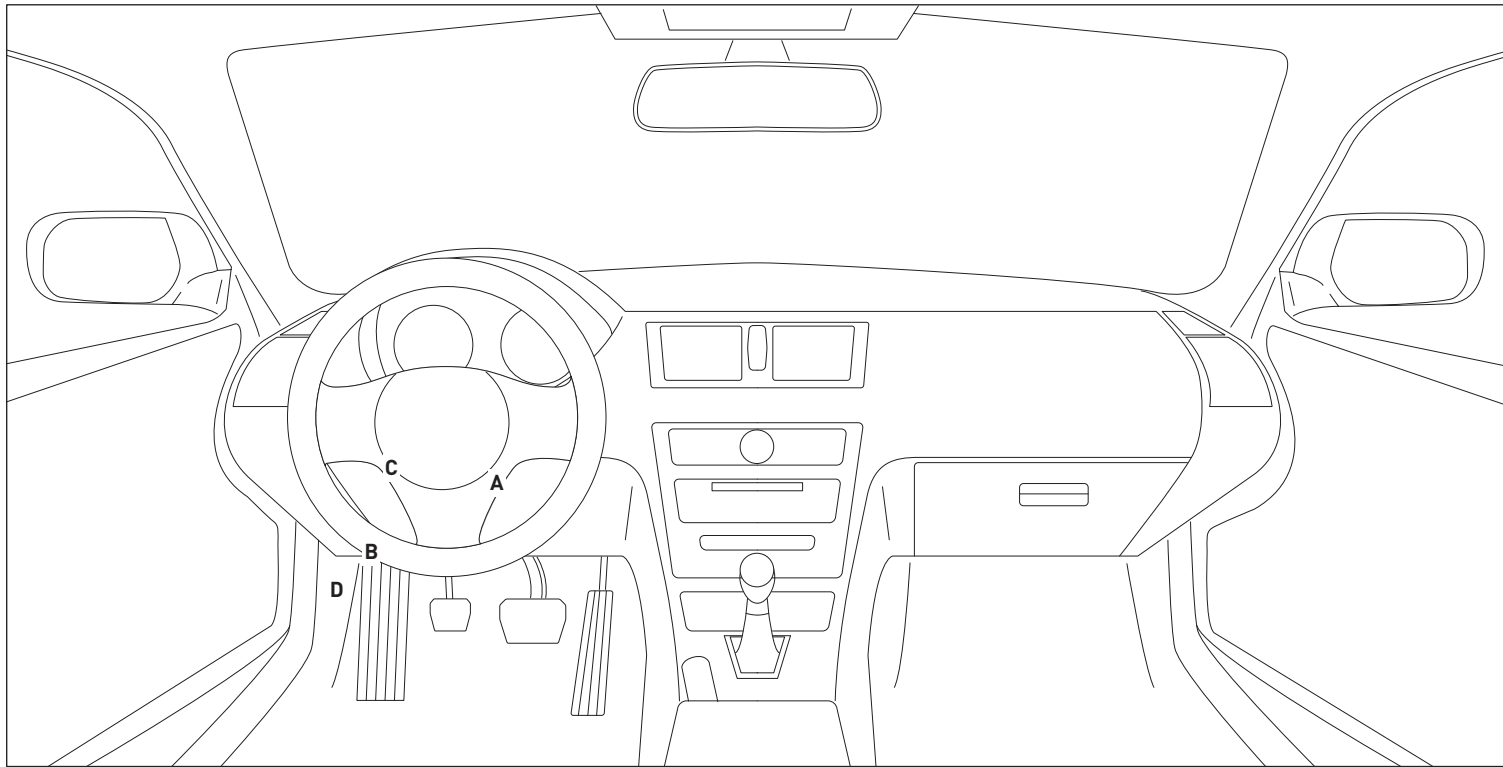

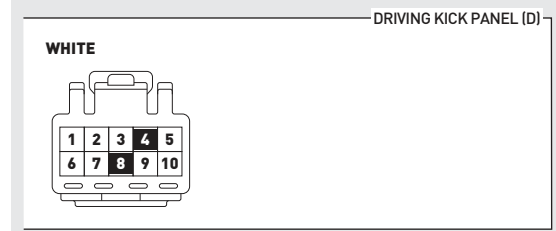
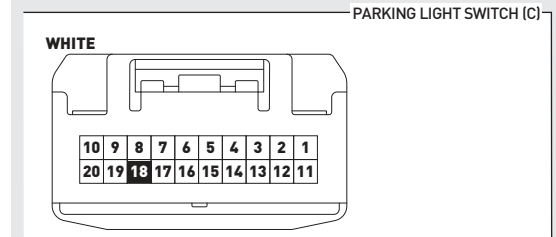
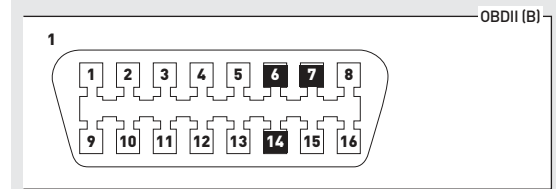
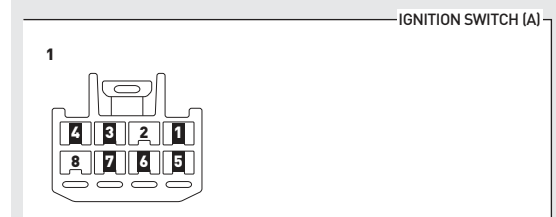
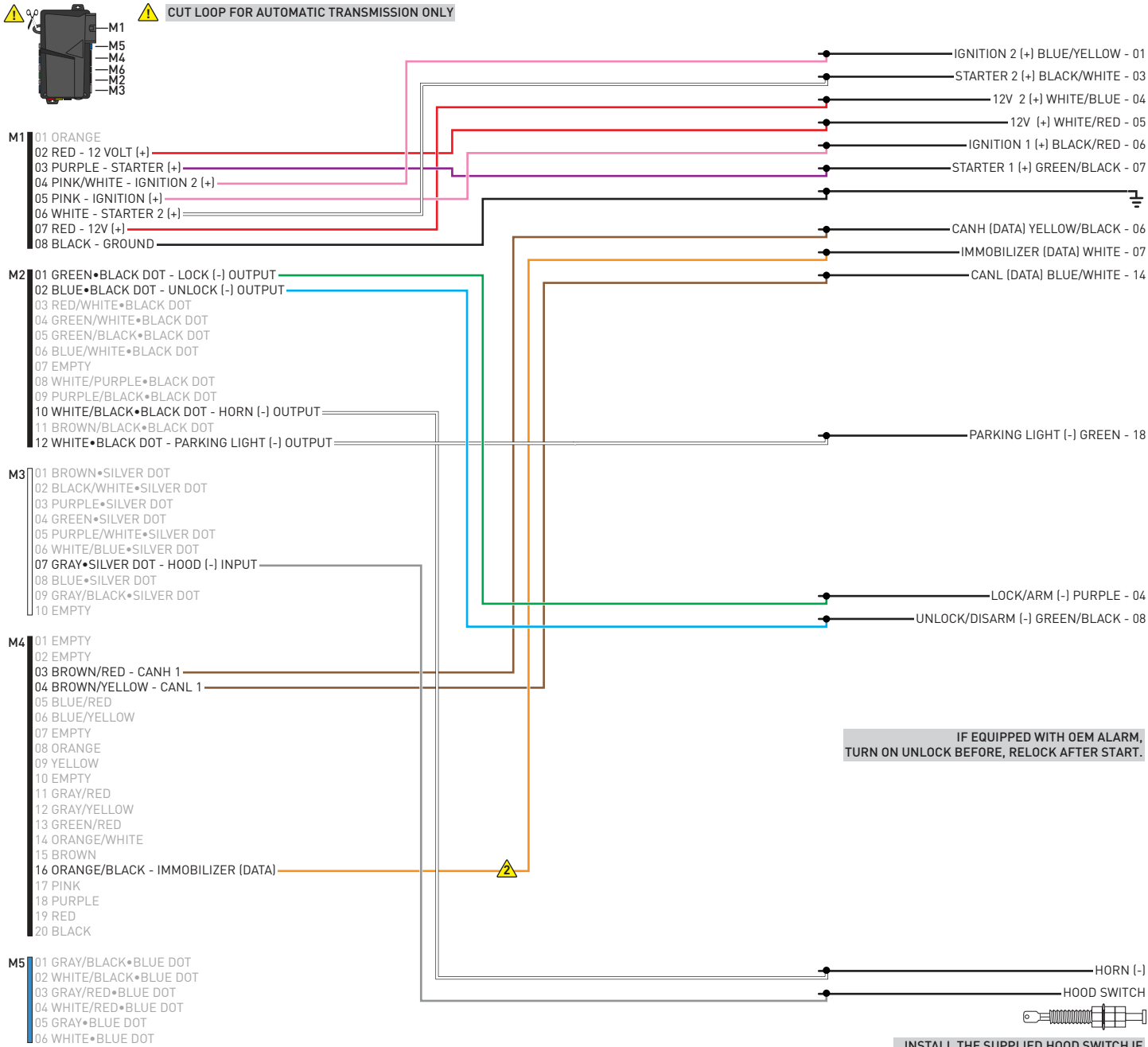



IF EQUIPPED WITH OEM ALARM,
TURN ON UNLOCK BEFORE, RELOCK AFTER START.

INSTALL THE SUPPLIED HOOD SWITCH IF
THE VEHICLE IS NOT EQUIPPED WITH ONE.

CONNECT ORANGE/BLACK WIRE TO GROUND IF
VEHICLE IS NOT EQUIPPED WITH IMMOBILIZER

01  Use the BLACK key only. DO NOT use the GRAY valet key.

02  Turn key to ON position.

03  Wait, LED 1 will turn solid GREEN for 2 seconds.

04  Turn key to OFF position.

05  START vehicle for 15 seconds.

06  Press and hold the brake pedal.

07  Press and release the module's programming button.

08  Release the brake pedal.

09  Wait, LED 2 will flash GREEN.

10  Module Programming Procedure completed.

>>



All vehicle doors must be closed and locked prior to remote start sequence.

01



Press unlock on OEM or aftermarket remote or request switch.

02



DO NOT PRESS BRAKE PEDAL. Set ignition to ON position. Wait 2 seconds for key validation.

03



Press and release BRAKE pedal.

04



Take over procedure completed.

>>



Failure to follow procedure will result in vehicle engine shutdown.

CHECKLIST - WITH AFTERMARKET KEYFOB	
1	WARNING: Vehicle engine will start many times. Test in a well ventilated area.
2	Close all vehicle doors, hood and trunk.
3	Press the LOCK button once [1x] on the aftermarket keyfob.
	Question 1: Do the doors lock?
<input type="checkbox"/>	YES: Go to next step.
<input type="checkbox"/>	NO: Verify the remote programming, the RF connections and the wired door lock/unlock connections as illustrated in the wiring diagram, if applicable. Repeat the test and call technical support, if the problem persists.
4	Press the UNLOCK button once [1x] on the aftermarket keyfob.
	Question 2: Do the doors unlock?
<input type="checkbox"/>	YES: Go to next step.
<input type="checkbox"/>	NO: Verify the remote programming, the RF connections and the wired door lock/unlock connections as illustrated in the wiring diagram, if applicable. Repeat the test and call technical support, if the problem persists.
5	Press the TRUNK release button once [1x] on the aftermarket keyfob if supported.
	Question 3: Does the trunk or hatch open/unlock?
<input type="checkbox"/>	YES: Close trunk or hatch and go to next step.
<input type="checkbox"/>	NO: Verify the remote programming, the RF connections and the wired trunk/hatch connections as illustrated in the wiring diagram, if applicable. Repeat the test and call technical support, if the problem persists.
6	Press the AUX 1 button once [1x] on the aftermarket keyfob if supported.
	Question 4: Does the driver side sliding door open?
<input type="checkbox"/>	YES: Press the AUX 1 button once [1x] to close the driver sliding door and go to next step.
<input type="checkbox"/>	NO: Verify the remote programming and the RF connections. Repeat the test and call technical support, if the problem persists.
7	Press the AUX 2 button once [1x] on the aftermarket keyfob if supported.
	Question 5: Does the passenger side sliding door open?
<input type="checkbox"/>	YES: Press the AUX 2 button once [1x] to close the passenger sliding door and go to next step.
<input type="checkbox"/>	NO: Verify the remote programming and the RF connections. Repeat the test and call technical support, if the problem persists.
8	Press the START/STOP button once [1x] on the aftermarket keyfob to remote start vehicle.
	Question 6: Does the vehicle remote start?
<input type="checkbox"/>	YES: Go to next step.
<input type="checkbox"/>	NO: Verify the remote programming, the RF connections and check the remote start error codes. Repeat the test and call technical support, if the problem persists.
9	Press the START/STOP button once [1x] on the aftermarket keyfob to shut down vehicle.
	Question 7: Does the vehicle shut down?
<input type="checkbox"/>	YES: Go to next step.
<input type="checkbox"/>	NO: Repeat step. If problem persists, press the brake pedal once [1x] to shut down the vehicle and call technical support.
10	RAP and auto light shutdown test
	Question 8: Did the radio, interior controls and headlights turn off within 60 seconds after remote start shutdown?
<input type="checkbox"/>	YES: Go to next step.
<input type="checkbox"/>	NO: Verify the RAP SHUTDOWN connections as illustrated in the wiring diagram. Repeat the test and call technical support if the problem persists.
11	Open hood.
12	If not already installed, affix the mandatory orange warning sticker under the hood and proceed to next step.
13	Press the START/STOP button once [1x] on the aftermarket keyfob to remote start vehicle.
	Question 9: Does the vehicle remote start?
<input type="checkbox"/>	YES: The vehicle is not equipped with a factory hood pin. Install a mandatory aftermarket hood switch, then repeat the test.
<input type="checkbox"/>	NO: Go to next step.
14	Close hood.
15	Enter vehicle and close the doors.
16	Press the START/STOP button once [1x] on the aftermarket keyfob to remote start vehicle.
17	Wait for the vehicle to start.
18	Press brake pedal.
	Question 10: Does the vehicle shut down?
<input type="checkbox"/>	YES: Go to next step.
<input type="checkbox"/>	NO: The module does NOT detect the brake pedal signal. Press the START/STOP button once [1x] on the aftermarket keyfob to shut down vehicle, check connection as illustrated in the wiring diagram, if applicable, and call technical support.
19	Exit vehicle.
20	Installation checklist completed.

CHECKLIST - WITH OEM KEYFOB	
1	WARNING: Vehicle engine will start many times. Test in a well ventilated area.
2	Close all vehicle doors, hood and trunk.
3	Press LOCK button three times [3x] rapidly on the OEM keyfob to remote start vehicle.
	Question 1: Does the vehicle remote start?
<input type="checkbox"/>	YES: Go to next step.
<input type="checkbox"/>	NO: The module doesn't detect OEM remote lock button from the vehicle communication network. Check all connections, repeat the test and call technical support, if the problem persists.
4	Press LOCK button three times [3x] rapidly on the OEM keyfob to shut down vehicle.
	Question 2: Does the vehicle shut down?
<input type="checkbox"/>	YES: Go to next step.
<input type="checkbox"/>	NO: Repeat step. If the problem persists, press on the brake pedal once [1x] to shut down the vehicle and call technical support.
5	RAP Shutdown test
	Question 3: Did the radio, interior controls, and headlights turn off within 60 seconds after remote start shutdown?
<input type="checkbox"/>	YES: Go to next step.
<input type="checkbox"/>	NO: Verify the RAP SHUTDOWN connections as illustrated in the wiring diagram. Repeat the test and call technical support, if the problem persists.
6	Open hood.
7	If not already installed, affix the mandatory orange warning sticker under the hood and proceed to next step.
8	Press LOCK button three times [3x] rapidly on the OEM keyfob to remote start vehicle.
	Question 4: Does the vehicle remote start?
<input type="checkbox"/>	YES: The vehicle is not equipped with a factory hood pin. Install a mandatory aftermarket hood switch, then repeat the test.
<input type="checkbox"/>	NO: Go to next step.
9	Close hood.
10	Enter vehicle and close the doors.
11	Press LOCK button three times [3x] rapidly on the OEM keyfob to remote start vehicle.
12	Wait for the vehicle to start.
13	Press brake pedal.
	Question 5: Does the vehicle shut down?
<input type="checkbox"/>	YES: Go to next step.
<input type="checkbox"/>	NO: The module does NOT detect the brake pedal signal. Press LOCK button three times [3x] rapidly on the OEM keyfob to shut down, check the brake connection as illustrated in the wiring diagram, if applicable, and call technical support.
14	Exit vehicle.
15	Installation checklist completed.

COMPUSTAR®

INSTALL GUIDE

2011-2017 TOYOTA TUNDRA 80-BIT STD KEY AT

DOCUMENT NUMBER

REVISION DATE

20180926

FIRMWARE

COM-RSA-TL5-[RS1B-DC3]

HARDWARE

RS1B-DC3

ACCESSORIES

ATTENTION: TO COMPLETE THIS INSTALLATION SOME ACCESSORIES MAY BE REQUIRED. VISIT OUR WEBSITE TO SEE ALL THE REQUIRED ACCESSORIES FOR YOUR VEHICLE.

TERMS OF USE

Automotive Data Solutions Inc. ("ADS") products are strictly intended for installation by Certified Technicians who are employed by a registered business specialized in the installation of automotive aftermarket electronics products. Prior to beginning installation of an ADS product in a vehicle, it is the Certified Technician's responsibility to review the most current Product Guide, Install Guide and vehicle-specific notes available in Weblink®. ADS is not responsible for any damages whatsoever, including but not limited to any consequential damages, incidental damages, damages for loss of time, loss of earnings, loss of profit, commercial loss, loss of economic opportunity and the like that may or may not have resulted from the use, misuse, improper installation or operation of its products. ADS reserves itself the right to suspend any Weblink® account without notice and decline to offer technical support to non-Certified Technicians, non-compliant Certified Technicians or end users.



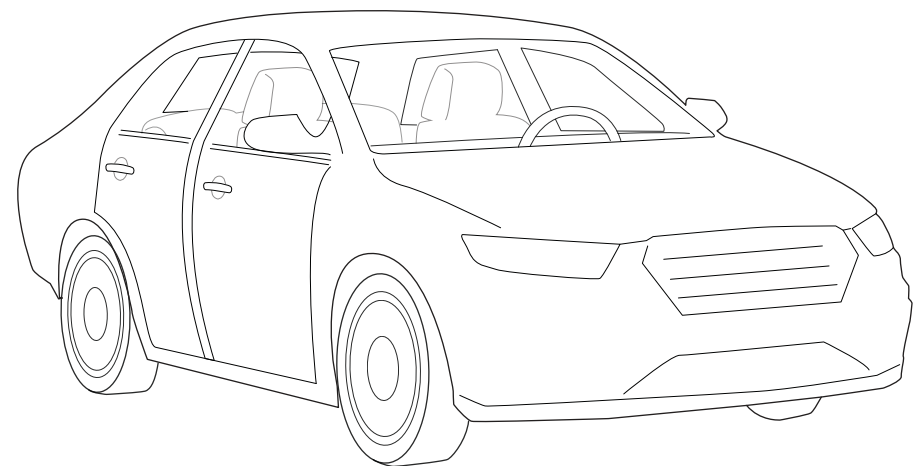
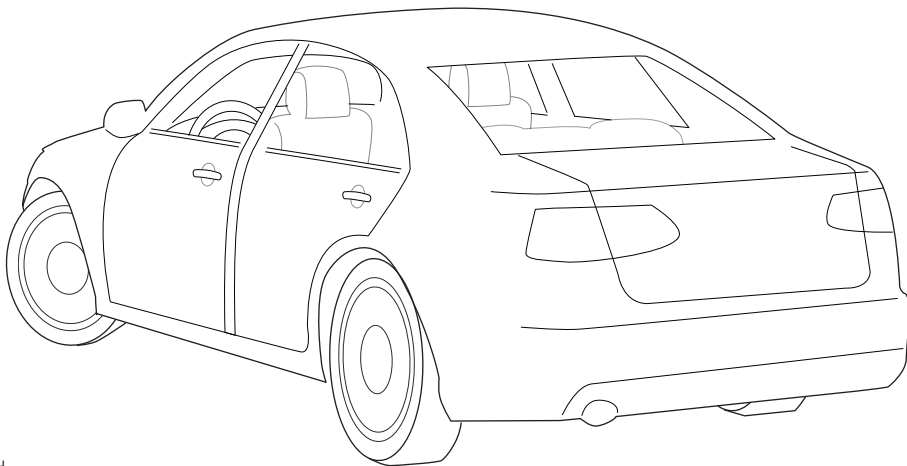
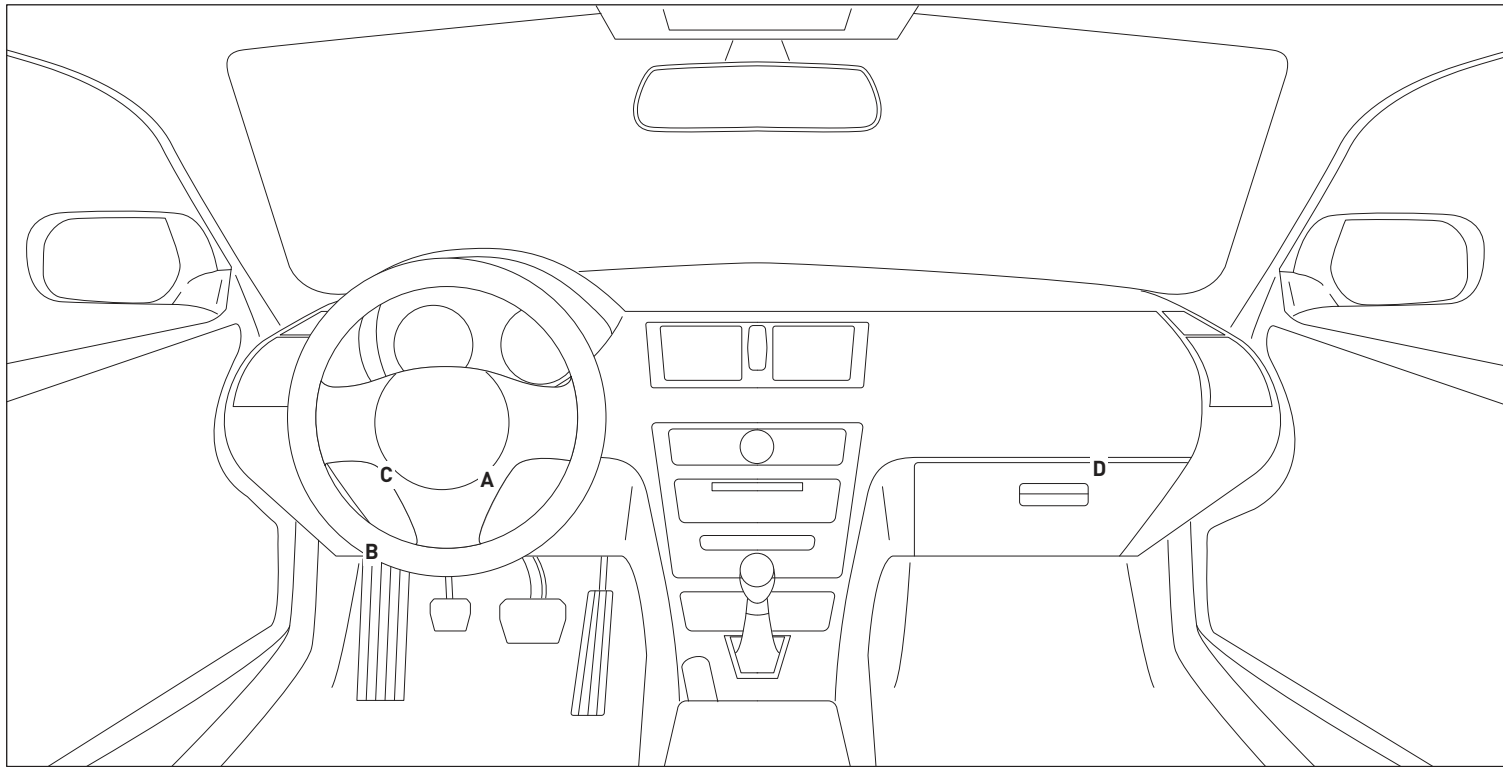

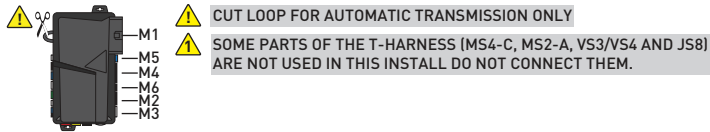

- M1 01
- 02
- 03
- 04
- 05
- 06
- 07
- 08

- M2 01 GREEN•BLACK DOT
- 02 BLUE•BLACK DOT
- 03 RED/WHITE•BLACK DOT
- 04 GREEN/WHITE•BLACK DOT
- 05 GREEN/BLACK•BLACK DOT
- 06 BLUE/WHITE•BLACK DOT
- 07 EMPTY
- 08 WHITE/PURPLE•BLACK DOT
- 09 PURPLE/BLACK•BLACK DOT
- 10 WHITE/BLACK•BLACK DOT - HORN (-) OUTPUT
- 11 BROWN/BLACK•BLACK DOT
- 12 WHITE•BLACK DOT - PARKING LIGHT (-) OUTPUT

- M3 01 BROWN•SILVER DOT
- 02 BLACK/WHITE•SILVER DOT
- 03 PURPLE•SILVER DOT
- 04 GREEN•SILVER DOT
- 05 PURPLE/WHITE•SILVER DOT
- 06 WHITE/BLUE•SILVER DOT
- 07 GRAY•SILVER DOT - HOOD (-) INPUT
- 08 BLUE•SILVER DOT
- 09 GRAY/BLACK•SILVER DOT
- 10 EMPTY

- M4 01
- 02
- 03
- 04
- 05
- 06
- 07
- 08
- 09
- 10
- 11
- 12
- 13
- 14
- 15
- 16
- 17
- 18
- 19
- 20

- M5 01
- 02
- 03
- 04
- 05
- 06

3 CONNECT BLACK WIRE TO GREEN/RED WIRE IF VEHICLE IS NOT EQUIPPED WITH IMMOBILIZER

5 IF NOT EQUIPPED WITH AN OEM HOOD PIN:
- INSTALL THE SUPPLIED HOOD SWITCH.
- CHANGE REMOTE STARTER INPUT CONFIGURATION (MENU #7) "4- HOOD INPUT SOURCE" TO "1- ANALOG".

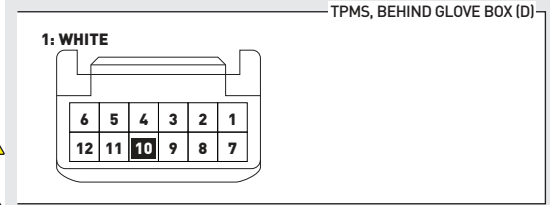
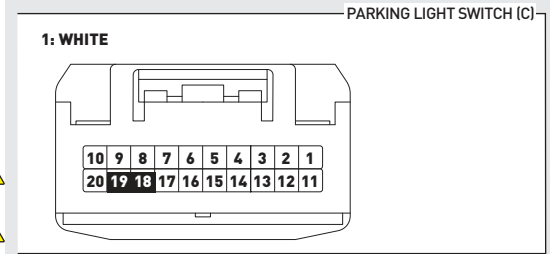
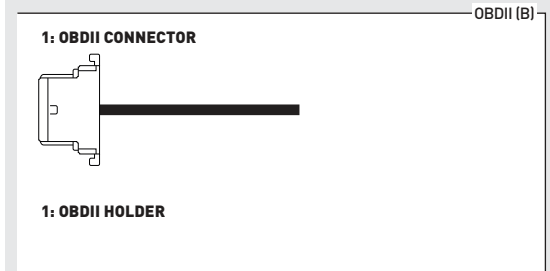
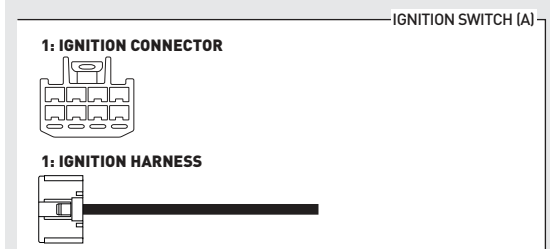
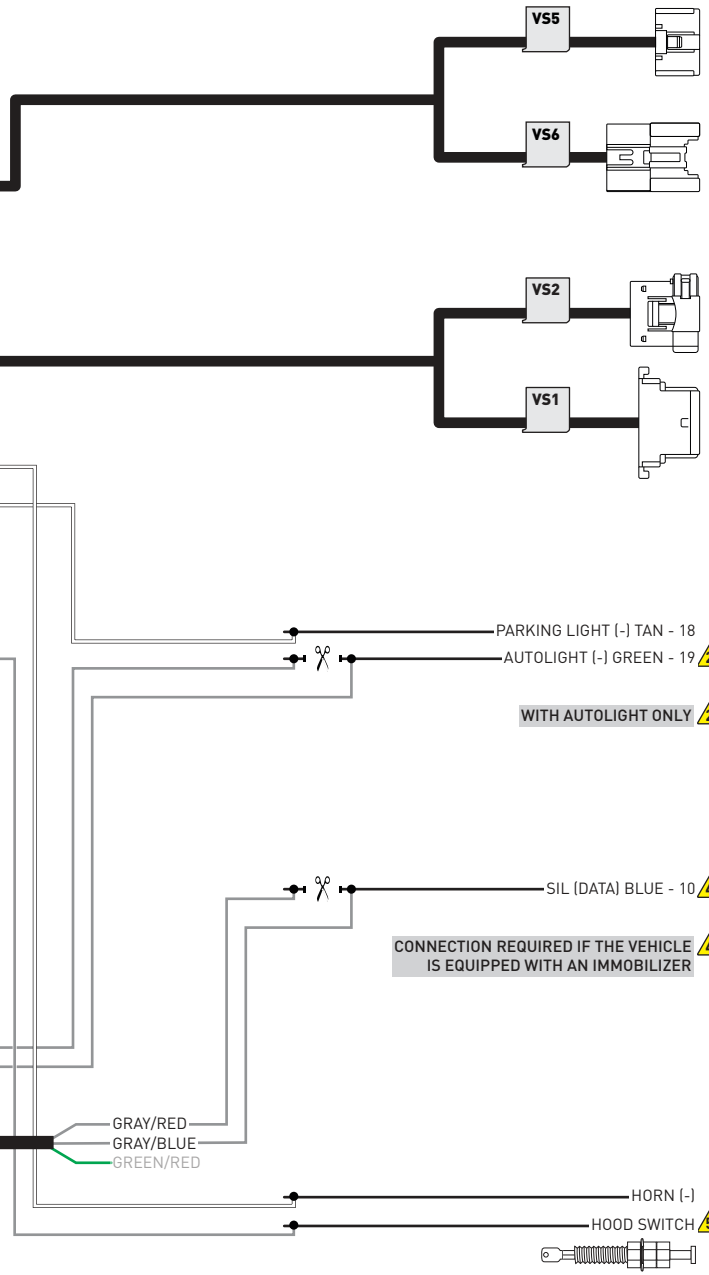

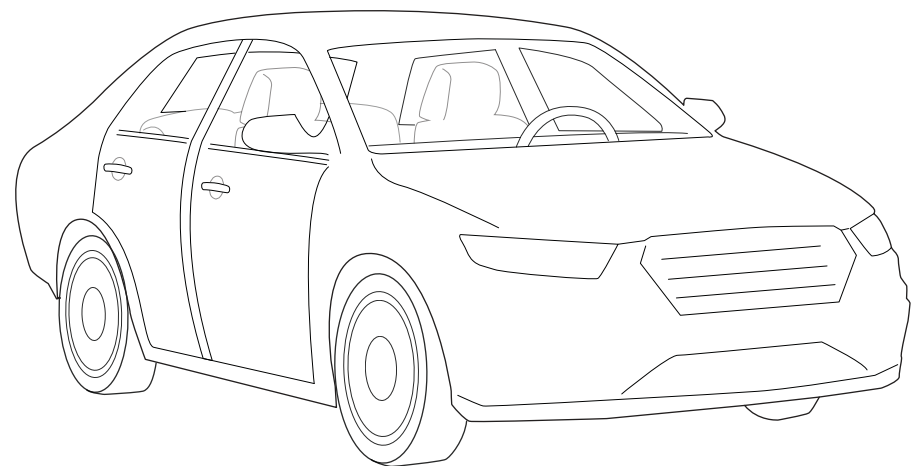
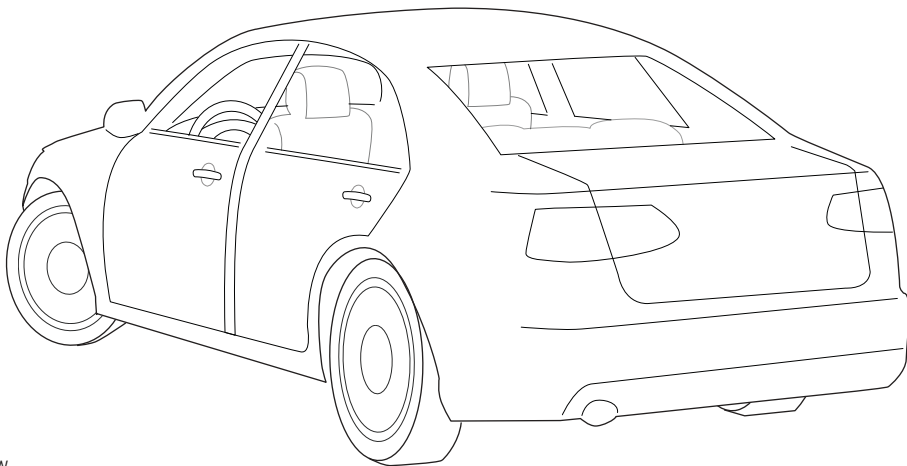
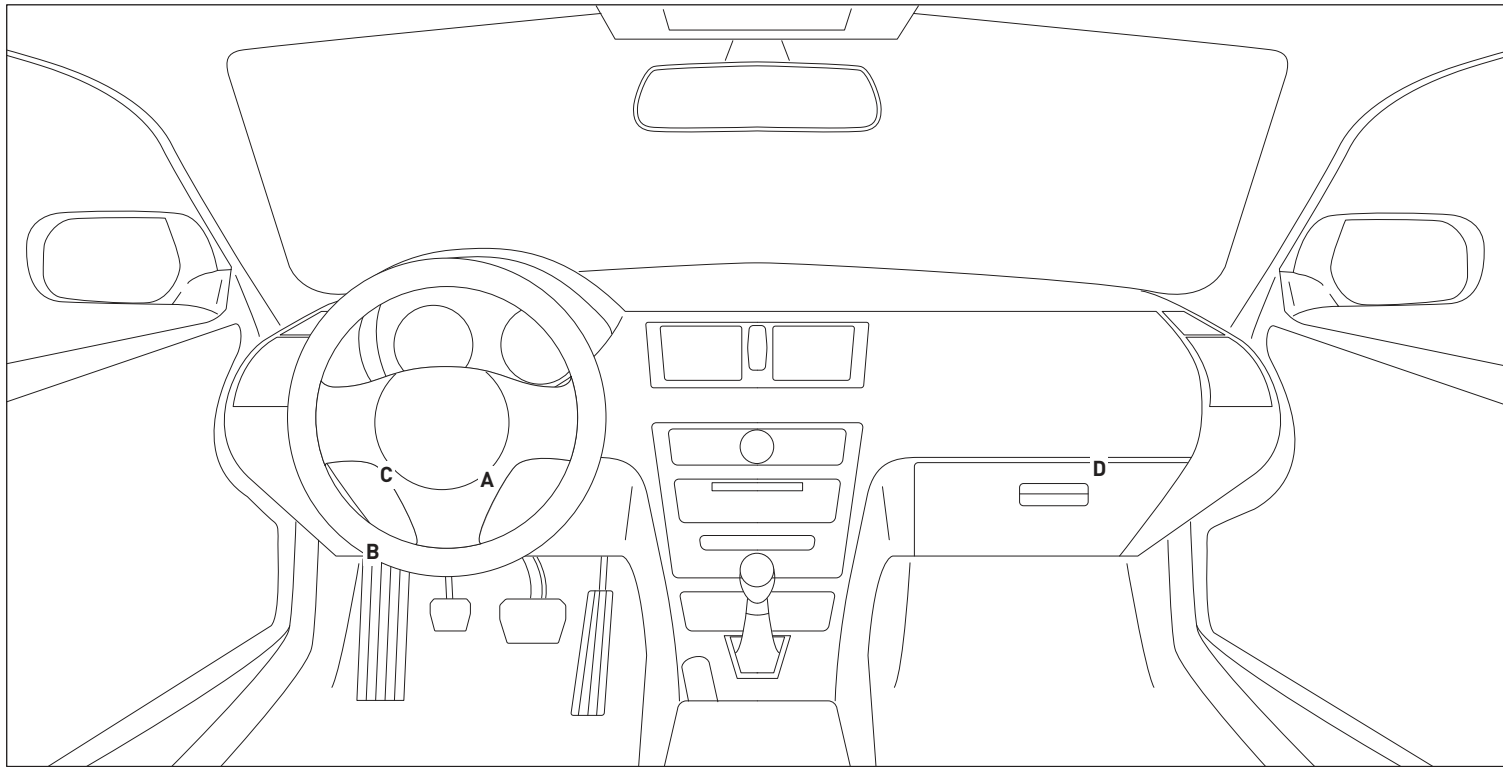

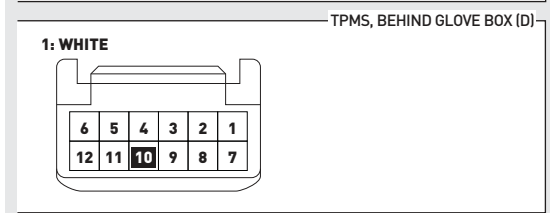
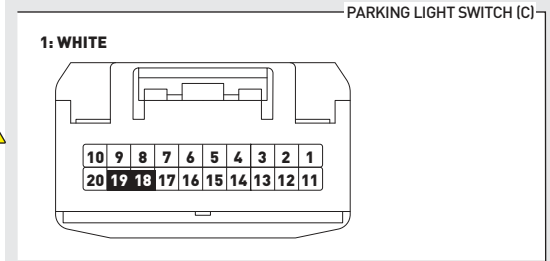
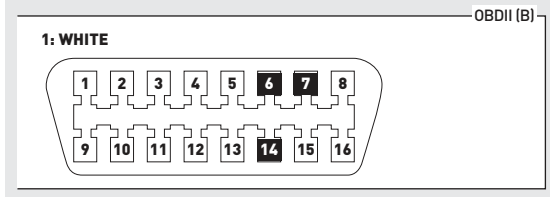
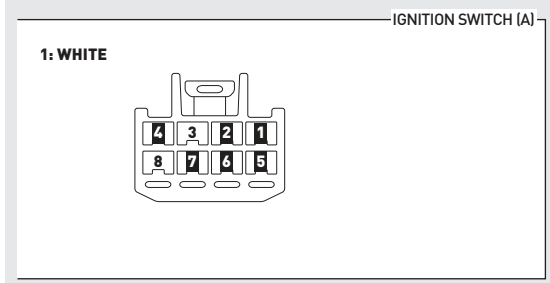
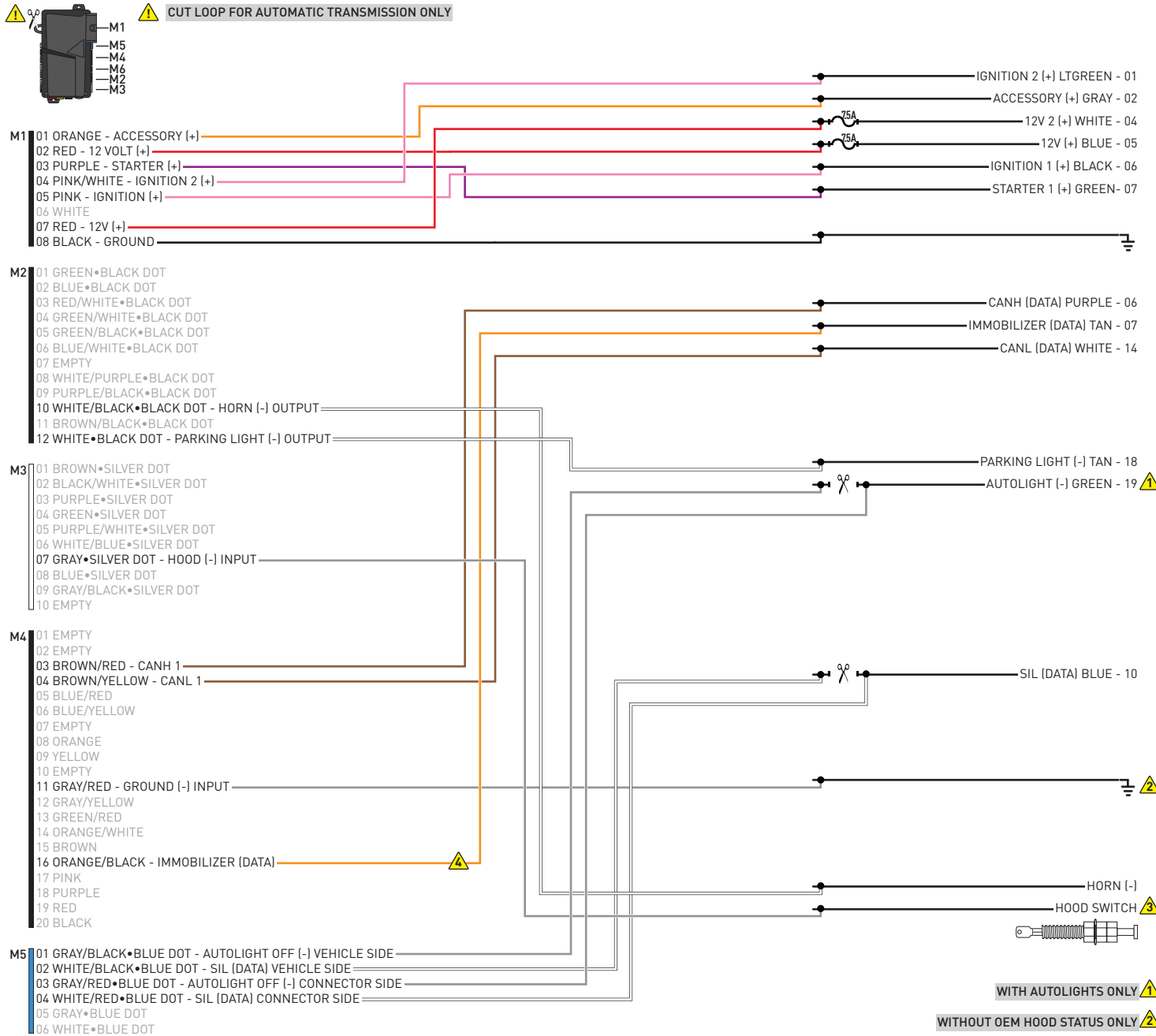

WITH AUTOLIGHTS ONLY ⚠

WITHOUT OEM HOOD STATUS ONLY ⚠

INSTALL THE SUPPLIED HOOD SWITCH IF THE VEHICLE IS NOT EQUIPPED WITH ONE. ⚠

CONNECT ORANGE/BLACK WIRE TO GROUND IF VEHICLE IS NOT EQUIPPED WITH IMMOBILIZER ⚠

01  Use the BLACK key only. DO NOT use the GRAY valet key.

02  Turn key to ON position.

03  Wait, LED 1 will turn solid GREEN for 2 seconds.

04  Turn key to OFF position.

05  START vehicle for 15 seconds.

06  Press and hold the brake pedal.

07  Press and release the module's programming button.

08  Release the brake pedal.

09  Wait, LED 2 will flash GREEN.

10  Module Programming Procedure completed.

>>



All vehicle doors must be closed and locked prior to remote start sequence.

01



Press unlock on OEM or aftermarket remote or request switch.

02



DO NOT PRESS BRAKE PEDAL. Set ignition to ON position. Wait 2 seconds for key validation.

03



Press and release BRAKE pedal.

04



Take over procedure completed.

>>



Failure to follow procedure will result in vehicle engine shutdown.

CHECKLIST - WITH AFTERMARKET KEYFOB	
1	WARNING: Vehicle engine will start many times. Test in a well ventilated area.
2	Close all vehicle doors, hood and trunk.
3	Press the LOCK button once [1x] on the aftermarket keyfob.
	Question 1: Do the doors lock?
<input type="checkbox"/>	YES: Go to next step.
<input type="checkbox"/>	NO: Verify the remote programming, the RF connections and the wired door lock/unlock connections as illustrated in the wiring diagram, if applicable. Repeat the test and call technical support, if the problem persists.
4	Press the UNLOCK button once [1x] on the aftermarket keyfob.
	Question 2: Do the doors unlock?
<input type="checkbox"/>	YES: Go to next step.
<input type="checkbox"/>	NO: Verify the remote programming, the RF connections and the wired door lock/unlock connections as illustrated in the wiring diagram, if applicable. Repeat the test and call technical support, if the problem persists.
5	Press the TRUNK release button once [1x] on the aftermarket keyfob if supported.
	Question 3: Does the trunk or hatch open/unlock?
<input type="checkbox"/>	YES: Close trunk or hatch and go to next step.
<input type="checkbox"/>	NO: Verify the remote programming, the RF connections and the wired trunk/hatch connections as illustrated in the wiring diagram, if applicable. Repeat the test and call technical support, if the problem persists.
6	Press the AUX 1 button once [1x] on the aftermarket keyfob if supported.
	Question 4: Does the driver side sliding door open?
<input type="checkbox"/>	YES: Press the AUX 1 button once [1x] to close the driver sliding door and go to next step.
<input type="checkbox"/>	NO: Verify the remote programming and the RF connections. Repeat the test and call technical support, if the problem persists.
7	Press the AUX 2 button once [1x] on the aftermarket keyfob if supported.
	Question 5: Does the passenger side sliding door open?
<input type="checkbox"/>	YES: Press the AUX 2 button once [1x] to close the passenger sliding door and go to next step.
<input type="checkbox"/>	NO: Verify the remote programming and the RF connections. Repeat the test and call technical support, if the problem persists.
8	Press the START/STOP button once [1x] on the aftermarket keyfob to remote start vehicle.
	Question 6: Does the vehicle remote start?
<input type="checkbox"/>	YES: Go to next step.
<input type="checkbox"/>	NO: Verify the remote programming, the RF connections and check the remote start error codes. Repeat the test and call technical support, if the problem persists.
9	Press the START/STOP button once [1x] on the aftermarket keyfob to shut down vehicle.
	Question 7: Does the vehicle shut down?
<input type="checkbox"/>	YES: Go to next step.
<input type="checkbox"/>	NO: Repeat step. If problem persists, press the brake pedal once [1x] to shut down the vehicle and call technical support.
10	RAP and auto light shutdown test
	Question 8: Did the radio, interior controls and headlights turn off within 60 seconds after remote start shutdown?
<input type="checkbox"/>	YES: Go to next step.
<input type="checkbox"/>	NO: Verify the RAP SHUTDOWN connections as illustrated in the wiring diagram. Repeat the test and call technical support if the problem persists.
11	Open hood.
12	If not already installed, affix the mandatory orange warning sticker under the hood and proceed to next step.
13	Press the START/STOP button once [1x] on the aftermarket keyfob to remote start vehicle.
	Question 9: Does the vehicle remote start?
<input type="checkbox"/>	YES: The vehicle is not equipped with a factory hood pin. Install a mandatory aftermarket hood switch, then repeat the test.
<input type="checkbox"/>	NO: Go to next step.
14	Close hood.
15	Enter vehicle and close the doors.
16	Press the START/STOP button once [1x] on the aftermarket keyfob to remote start vehicle.
17	Wait for the vehicle to start.
18	Press brake pedal.
	Question 10: Does the vehicle shut down?
<input type="checkbox"/>	YES: Go to next step.
<input type="checkbox"/>	NO: The module does NOT detect the brake pedal signal. Press the START/STOP button once [1x] on the aftermarket keyfob to shut down vehicle, check connection as illustrated in the wiring diagram, if applicable, and call technical support.
19	Exit vehicle.
20	Installation checklist completed.

CHECKLIST - WITH OEM KEYFOB	
1	WARNING: Vehicle engine will start many times. Test in a well ventilated area.
2	Close all vehicle doors, hood and trunk.
3	Press LOCK button three times [3x] rapidly on the OEM keyfob to remote start vehicle.
	Question 1: Does the vehicle remote start?
<input type="checkbox"/>	YES: Go to next step.
<input type="checkbox"/>	NO: The module doesn't detect OEM remote lock button from the vehicle communication network. Check all connections, repeat the test and call technical support, if the problem persists.
4	Press LOCK button three times [3x] rapidly on the OEM keyfob to shut down vehicle.
	Question 2: Does the vehicle shut down?
<input type="checkbox"/>	YES: Go to next step.
<input type="checkbox"/>	NO: Repeat step. If the problem persists, press on the brake pedal once [1x] to shut down the vehicle and call technical support.
5	RAP Shutdown test
	Question 3: Did the radio, interior controls, and headlights turn off within 60 seconds after remote start shutdown?
<input type="checkbox"/>	YES: Go to next step.
<input type="checkbox"/>	NO: Verify the RAP SHUTDOWN connections as illustrated in the wiring diagram. Repeat the test and call technical support, if the problem persists.
6	Open hood.
7	If not already installed, affix the mandatory orange warning sticker under the hood and proceed to next step.
8	Press LOCK button three times [3x] rapidly on the OEM keyfob to remote start vehicle.
	Question 4: Does the vehicle remote start?
<input type="checkbox"/>	YES: The vehicle is not equipped with a factory hood pin. Install a mandatory aftermarket hood switch, then repeat the test.
<input type="checkbox"/>	NO: Go to next step.
9	Close hood.
10	Enter vehicle and close the doors.
11	Press LOCK button three times [3x] rapidly on the OEM keyfob to remote start vehicle.
12	Wait for the vehicle to start.
13	Press brake pedal.
	Question 5: Does the vehicle shut down?
<input type="checkbox"/>	YES: Go to next step.
<input type="checkbox"/>	NO: The module does NOT detect the brake pedal signal. Press LOCK button three times [3x] rapidly on the OEM keyfob to shut down, check the brake connection as illustrated in the wiring diagram, if applicable, and call technical support.
14	Exit vehicle.
15	Installation checklist completed.

COMPUSTAR®

INSTALL GUIDE

2010-2016 TOYOTA VENZA 80-BIT STD KEY AT



DOCUMENT NUMBER

REVISION DATE

20180926

FIRMWARE

COM-RSA-TL5-[RS1B-DC3]

HARDWARE

RS1B-DC3

ACCESSORIES

ATTENTION: TO COMPLETE THIS INSTALLATION SOME ACCESSORIES MAY BE REQUIRED. VISIT OUR WEBSITE TO SEE ALL THE REQUIRED ACCESSORIES FOR YOUR VEHICLE.

TERMS OF USE

Automotive Data Solutions Inc. ("ADS") products are strictly intended for installation by Certified Technicians who are employed by a registered business specialized in the installation of automotive aftermarket electronics products. Prior to beginning installation of an ADS product in a vehicle, it is the Certified Technician's responsibility to review the most current Product Guide, Install Guide and vehicle-specific notes available in Weblink®. ADS is not responsible for any damages whatsoever, including but not limited to any consequential damages, incidental damages, damages for loss of time, loss of earnings, loss of profit, commercial loss, loss of economic opportunity and the like that may or may not have resulted from the use, misuse, improper installation or operation of its products. ADS reserves itself the right to suspend any Weblink® account without notice and decline to offer technical support to non-Certified Technicians, non-compliant Certified Technicians or end users.

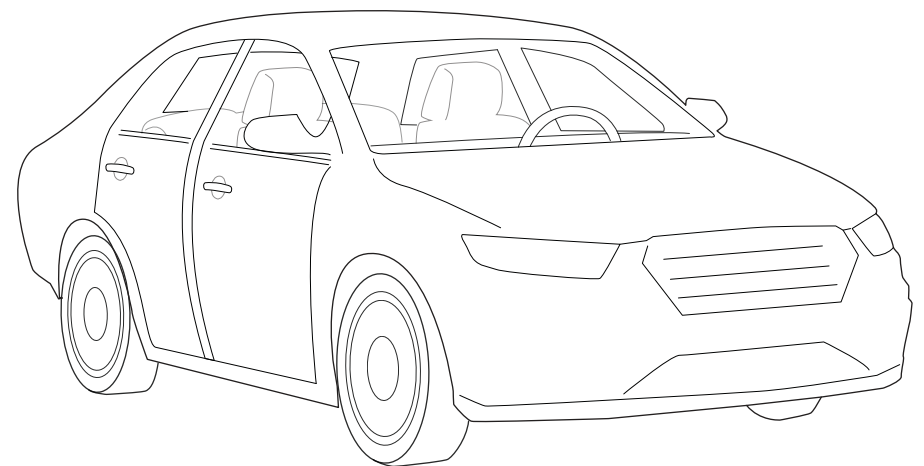
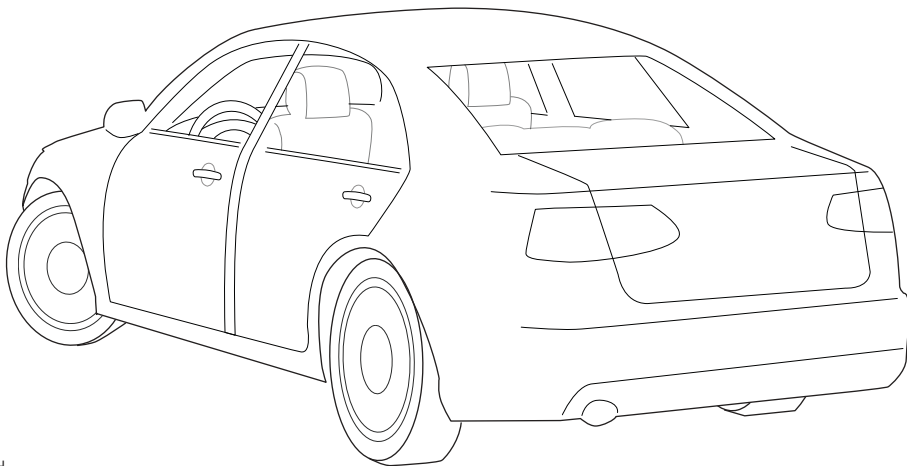
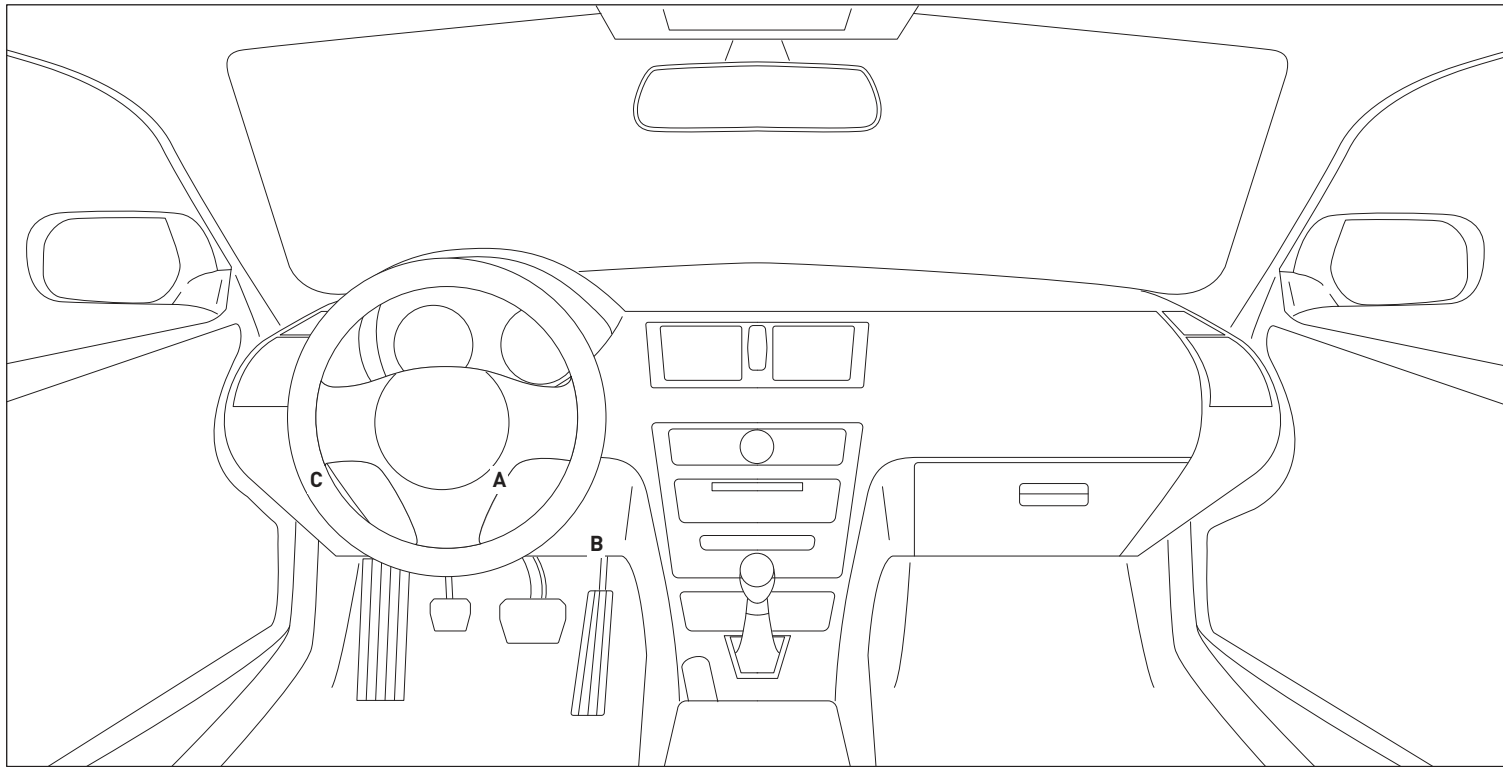

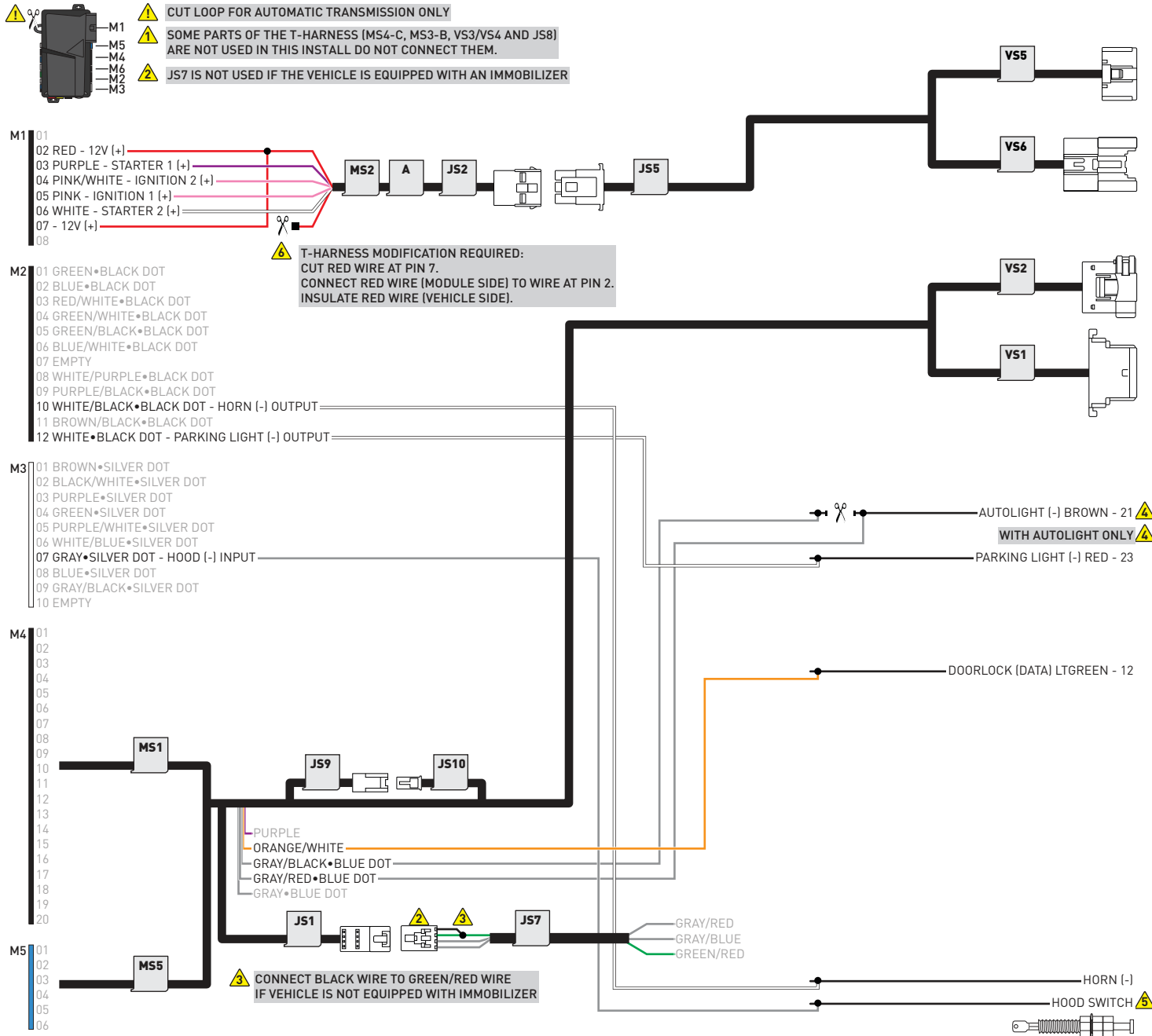

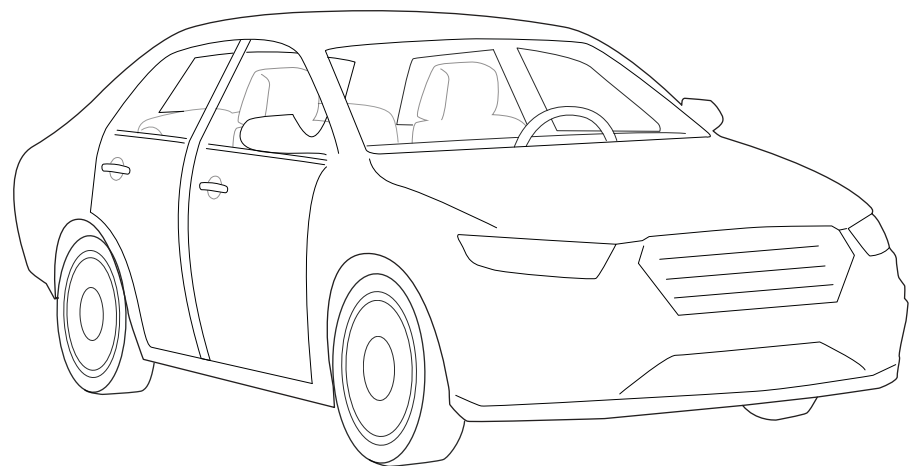
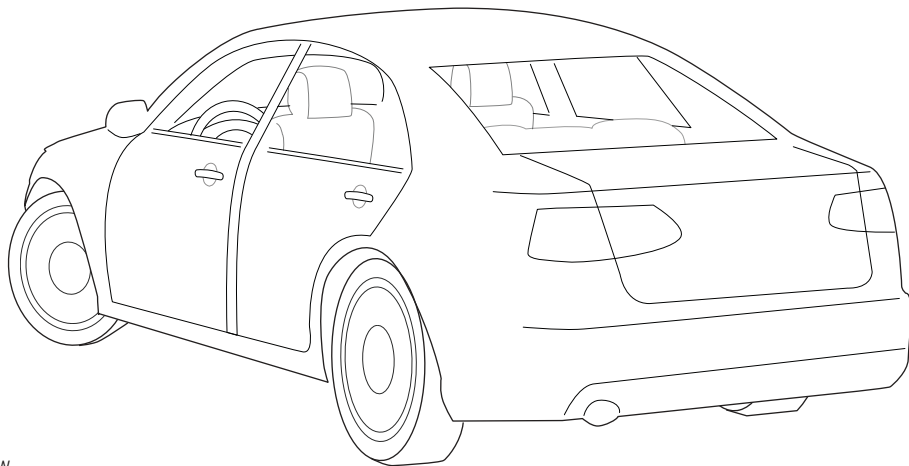
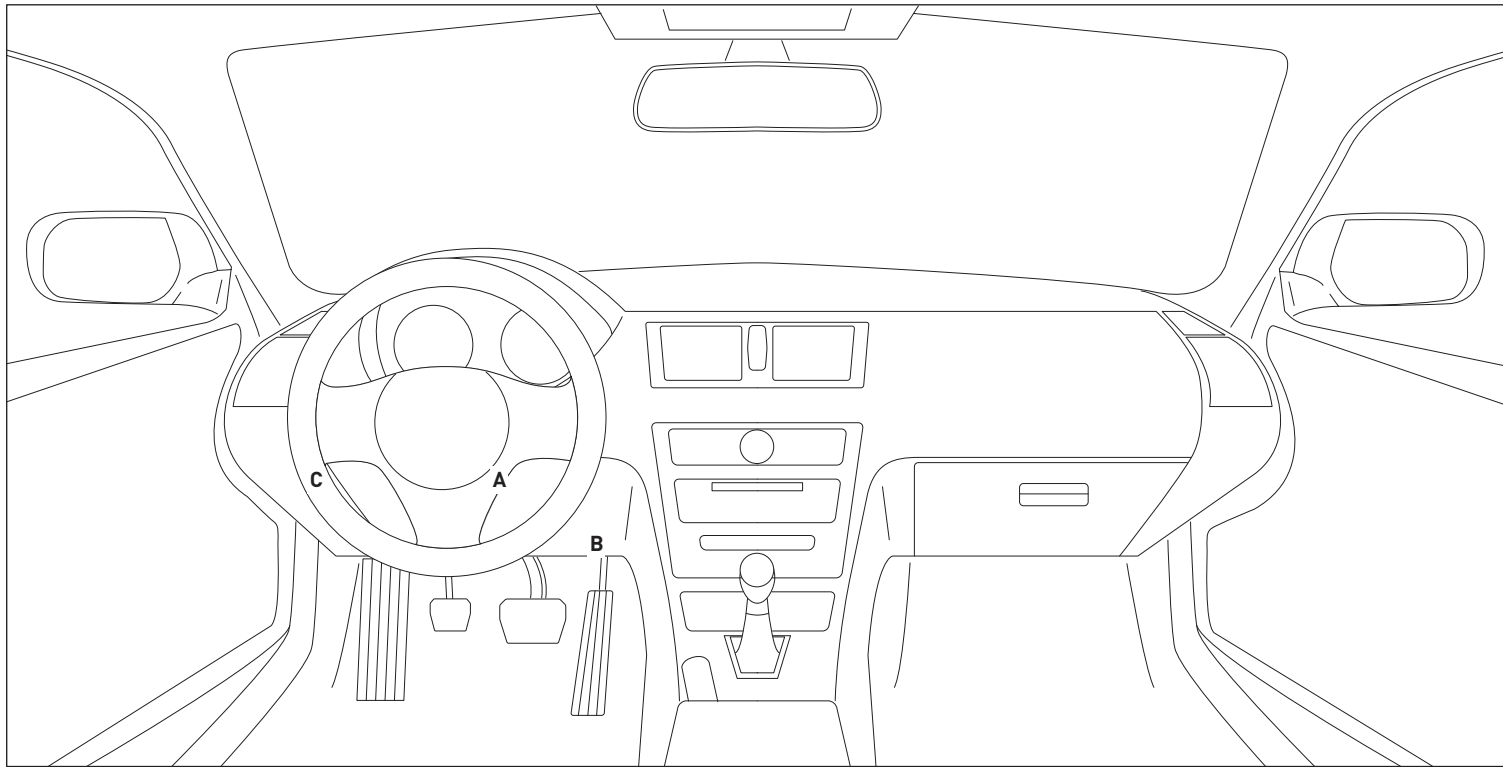

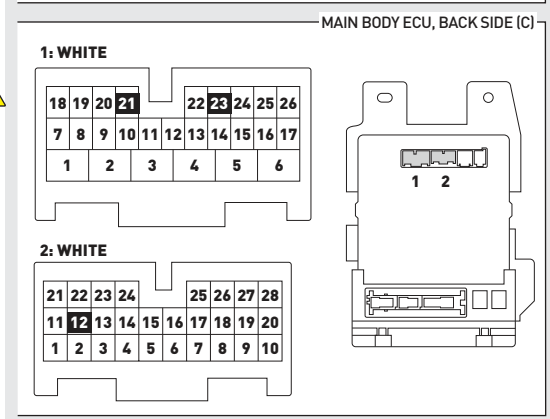
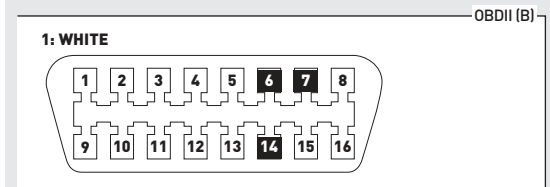
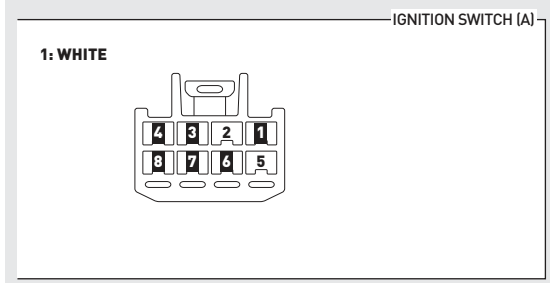
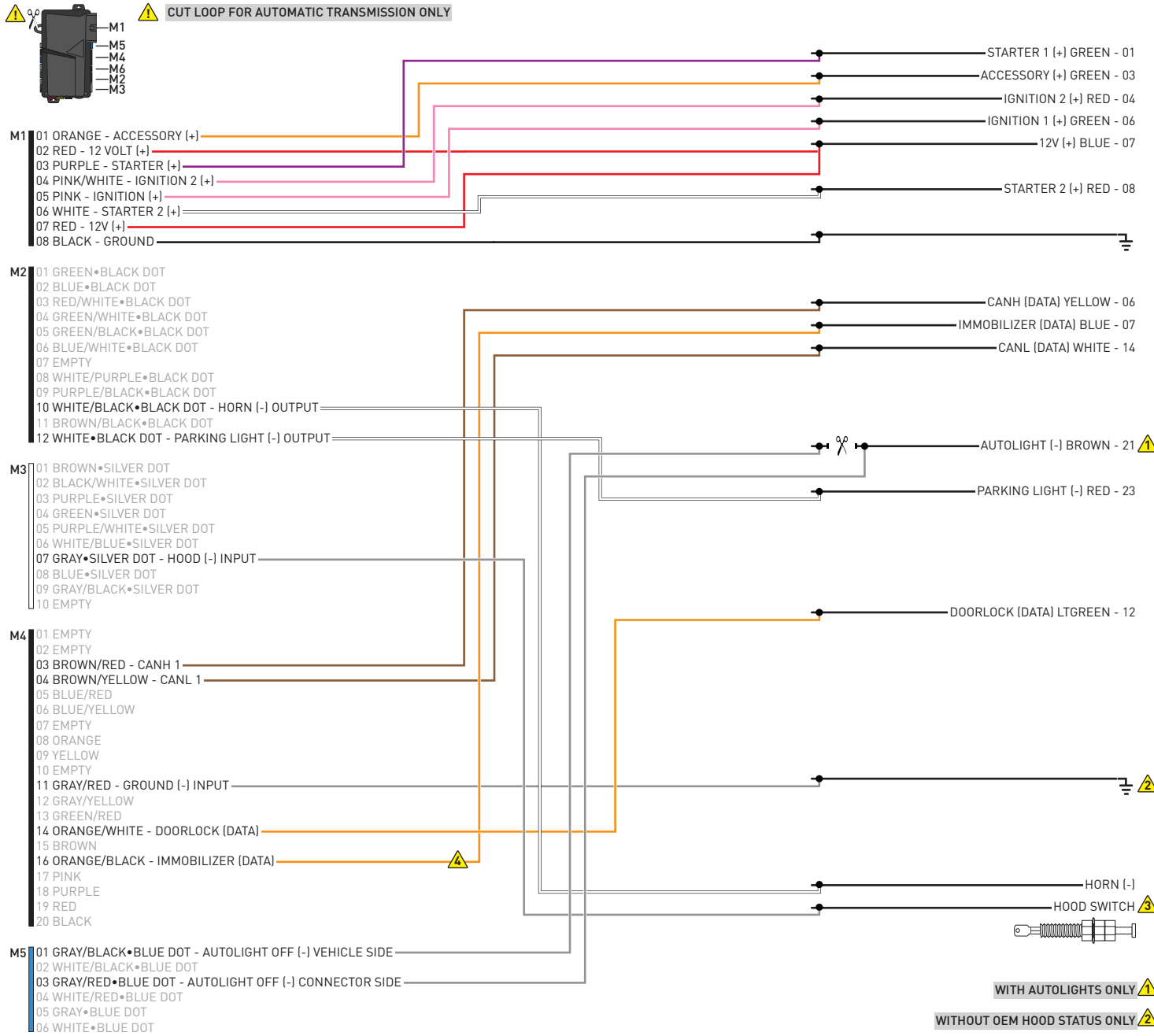



01  Use the BLACK key only. DO NOT use the GRAY valet key.

02  Turn key to ON position.

03  Wait, LED 1 will turn solid GREEN for 2 seconds.

04  Turn key to OFF position.

05  START vehicle for 15 seconds.

06  Press and hold the brake pedal.

07  Press and release the module's programming button.

08  Release the brake pedal.

09  Wait, LED 2 will flash GREEN.

10  Module Programming Procedure completed.

>>



All vehicle doors must be closed and locked prior to remote start sequence.

01



Press unlock on OEM or aftermarket remote or request switch.

02



DO NOT PRESS BRAKE PEDAL. Set ignition to ON position. Wait 2 seconds for key validation.

03



Press and release BRAKE pedal.

04



Take over procedure completed.

>>



Failure to follow procedure will result in vehicle engine shutdown.

CHECKLIST - WITH AFTERMARKET KEYFOB	
1	WARNING: Vehicle engine will start many times. Test in a well ventilated area.
2	Close all vehicle doors, hood and trunk.
3	Press the LOCK button once [1x] on the aftermarket keyfob.
	Question 1: Do the doors lock?
<input type="checkbox"/>	YES: Go to next step.
<input type="checkbox"/>	NO: Verify the remote programming, the RF connections and the wired door lock/unlock connections as illustrated in the wiring diagram, if applicable. Repeat the test and call technical support, if the problem persists.
4	Press the UNLOCK button once [1x] on the aftermarket keyfob.
	Question 2: Do the doors unlock?
<input type="checkbox"/>	YES: Go to next step.
<input type="checkbox"/>	NO: Verify the remote programming, the RF connections and the wired door lock/unlock connections as illustrated in the wiring diagram, if applicable. Repeat the test and call technical support, if the problem persists.
5	Press the TRUNK release button once [1x] on the aftermarket keyfob if supported.
	Question 3: Does the trunk or hatch open/unlock?
<input type="checkbox"/>	YES: Close trunk or hatch and go to next step.
<input type="checkbox"/>	NO: Verify the remote programming, the RF connections and the wired trunk/hatch connections as illustrated in the wiring diagram, if applicable. Repeat the test and call technical support, if the problem persists.
6	Press the AUX 1 button once [1x] on the aftermarket keyfob if supported.
	Question 4: Does the driver side sliding door open?
<input type="checkbox"/>	YES: Press the AUX 1 button once [1x] to close the driver sliding door and go to next step.
<input type="checkbox"/>	NO: Verify the remote programming and the RF connections. Repeat the test and call technical support, if the problem persists.
7	Press the AUX 2 button once [1x] on the aftermarket keyfob if supported.
	Question 5: Does the passenger side sliding door open?
<input type="checkbox"/>	YES: Press the AUX 2 button once [1x] to close the passenger sliding door and go to next step.
<input type="checkbox"/>	NO: Verify the remote programming and the RF connections. Repeat the test and call technical support, if the problem persists.
8	Press the START/STOP button once [1x] on the aftermarket keyfob to remote start vehicle.
	Question 6: Does the vehicle remote start?
<input type="checkbox"/>	YES: Go to next step.
<input type="checkbox"/>	NO: Verify the remote programming, the RF connections and check the remote start error codes. Repeat the test and call technical support, if the problem persists.
9	Press the START/STOP button once [1x] on the aftermarket keyfob to shut down vehicle.
	Question 7: Does the vehicle shut down?
<input type="checkbox"/>	YES: Go to next step.
<input type="checkbox"/>	NO: Repeat step. If problem persists, press the brake pedal once [1x] to shut down the vehicle and call technical support.
10	RAP and auto light shutdown test
	Question 8: Did the radio, interior controls and headlights turn off within 60 seconds after remote start shutdown?
<input type="checkbox"/>	YES: Go to next step.
<input type="checkbox"/>	NO: Verify the RAP SHUTDOWN connections as illustrated in the wiring diagram. Repeat the test and call technical support if the problem persists.
11	Open hood.
12	If not already installed, affix the mandatory orange warning sticker under the hood and proceed to next step.
13	Press the START/STOP button once [1x] on the aftermarket keyfob to remote start vehicle.
	Question 9: Does the vehicle remote start?
<input type="checkbox"/>	YES: The vehicle is not equipped with a factory hood pin. Install a mandatory aftermarket hood switch, then repeat the test.
<input type="checkbox"/>	NO: Go to next step.
14	Close hood.
15	Enter vehicle and close the doors.
16	Press the START/STOP button once [1x] on the aftermarket keyfob to remote start vehicle.
17	Wait for the vehicle to start.
18	Press brake pedal.
	Question 10: Does the vehicle shut down?
<input type="checkbox"/>	YES: Go to next step.
<input type="checkbox"/>	NO: The module does NOT detect the brake pedal signal. Press the START/STOP button once [1x] on the aftermarket keyfob to shut down vehicle, check connection as illustrated in the wiring diagram, if applicable, and call technical support.
19	Exit vehicle.
20	Installation checklist completed.

CHECKLIST - WITH OEM KEYFOB	
1	WARNING: Vehicle engine will start many times. Test in a well ventilated area.
2	Close all vehicle doors, hood and trunk.
3	Press LOCK button three times [3x] rapidly on the OEM keyfob to remote start vehicle.
	Question 1: Does the vehicle remote start?
<input type="checkbox"/>	YES: Go to next step.
<input type="checkbox"/>	NO: The module doesn't detect OEM remote lock button from the vehicle communication network. Check all connections, repeat the test and call technical support, if the problem persists.
4	Press LOCK button three times [3x] rapidly on the OEM keyfob to shut down vehicle.
	Question 2: Does the vehicle shut down?
<input type="checkbox"/>	YES: Go to next step.
<input type="checkbox"/>	NO: Repeat step. If the problem persists, press on the brake pedal once [1x] to shut down the vehicle and call technical support.
5	RAP Shutdown test
	Question 3: Did the radio, interior controls, and headlights turn off within 60 seconds after remote start shutdown?
<input type="checkbox"/>	YES: Go to next step.
<input type="checkbox"/>	NO: Verify the RAP SHUTDOWN connections as illustrated in the wiring diagram. Repeat the test and call technical support, if the problem persists.
6	Open hood.
7	If not already installed, affix the mandatory orange warning sticker under the hood and proceed to next step.
8	Press LOCK button three times [3x] rapidly on the OEM keyfob to remote start vehicle.
	Question 4: Does the vehicle remote start?
<input type="checkbox"/>	YES: The vehicle is not equipped with a factory hood pin. Install a mandatory aftermarket hood switch, then repeat the test.
<input type="checkbox"/>	NO: Go to next step.
9	Close hood.
10	Enter vehicle and close the doors.
11	Press LOCK button three times [3x] rapidly on the OEM keyfob to remote start vehicle.
12	Wait for the vehicle to start.
13	Press brake pedal.
	Question 5: Does the vehicle shut down?
<input type="checkbox"/>	YES: Go to next step.
<input type="checkbox"/>	NO: The module does NOT detect the brake pedal signal. Press LOCK button three times [3x] rapidly on the OEM keyfob to shut down, check the brake connection as illustrated in the wiring diagram, if applicable, and call technical support.
14	Exit vehicle.
15	Installation checklist completed.

COMPUSTAR®

INSTALL GUIDE

2011-2012 TOYOTA YARIS SEDAN 80-BIT STD KEY AT

DOCUMENT NUMBER

REVISION DATE

20180926

FIRMWARE

COM-RSA-TL5-[RS1B-DC3]

HARDWARE

RS1B-DC3

ACCESSORIES

ATTENTION: TO COMPLETE THIS INSTALLATION SOME ACCESSORIES MAY BE REQUIRED.
VISIT OUR WEBSITE TO SEE ALL THE REQUIRED ACCESSORIES FOR YOUR VEHICLE.

TERMS OF USE

Automotive Data Solutions Inc. ("ADS") products are strictly intended for installation by Certified Technicians who are employed by a registered business specialized in the installation of automotive aftermarket electronics products. Prior to beginning installation of an ADS product in a vehicle, it is the Certified Technician's responsibility to review the most current Product Guide, Install Guide and vehicle-specific notes available in Weblink®. ADS is not responsible for any damages whatsoever, including but not limited to any consequential damages, incidental damages, damages for loss of time, loss of earnings, loss of profit, commercial loss, loss of economic opportunity and the like that may or may not have resulted from the use, misuse, improper installation or operation of its products. ADS reserves itself the right to suspend any Weblink® account without notice and decline to offer technical support to non-Certified Technicians, non-compliant Certified Technicians or end users.



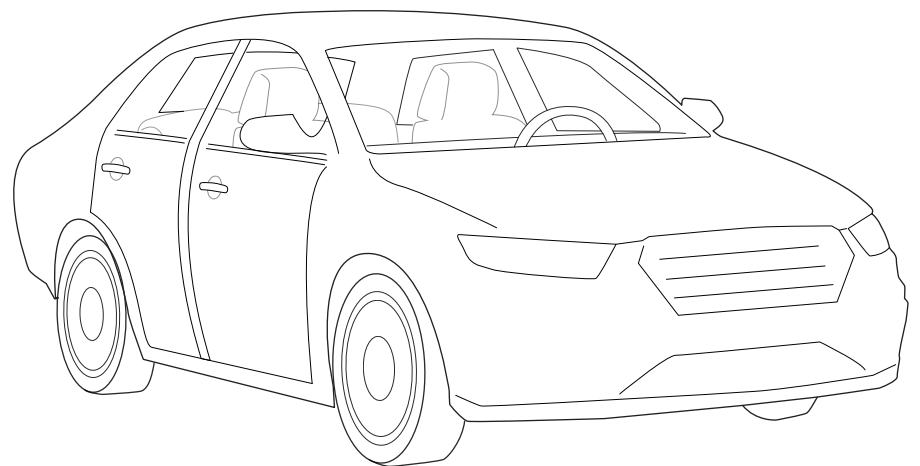
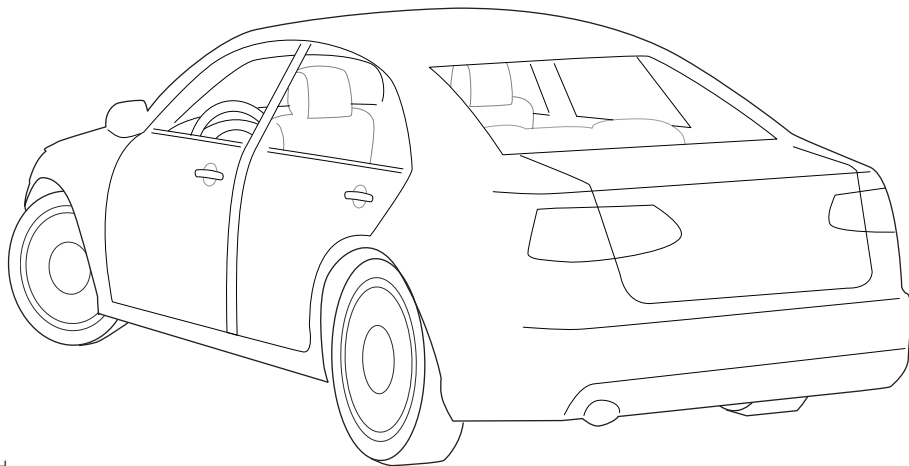
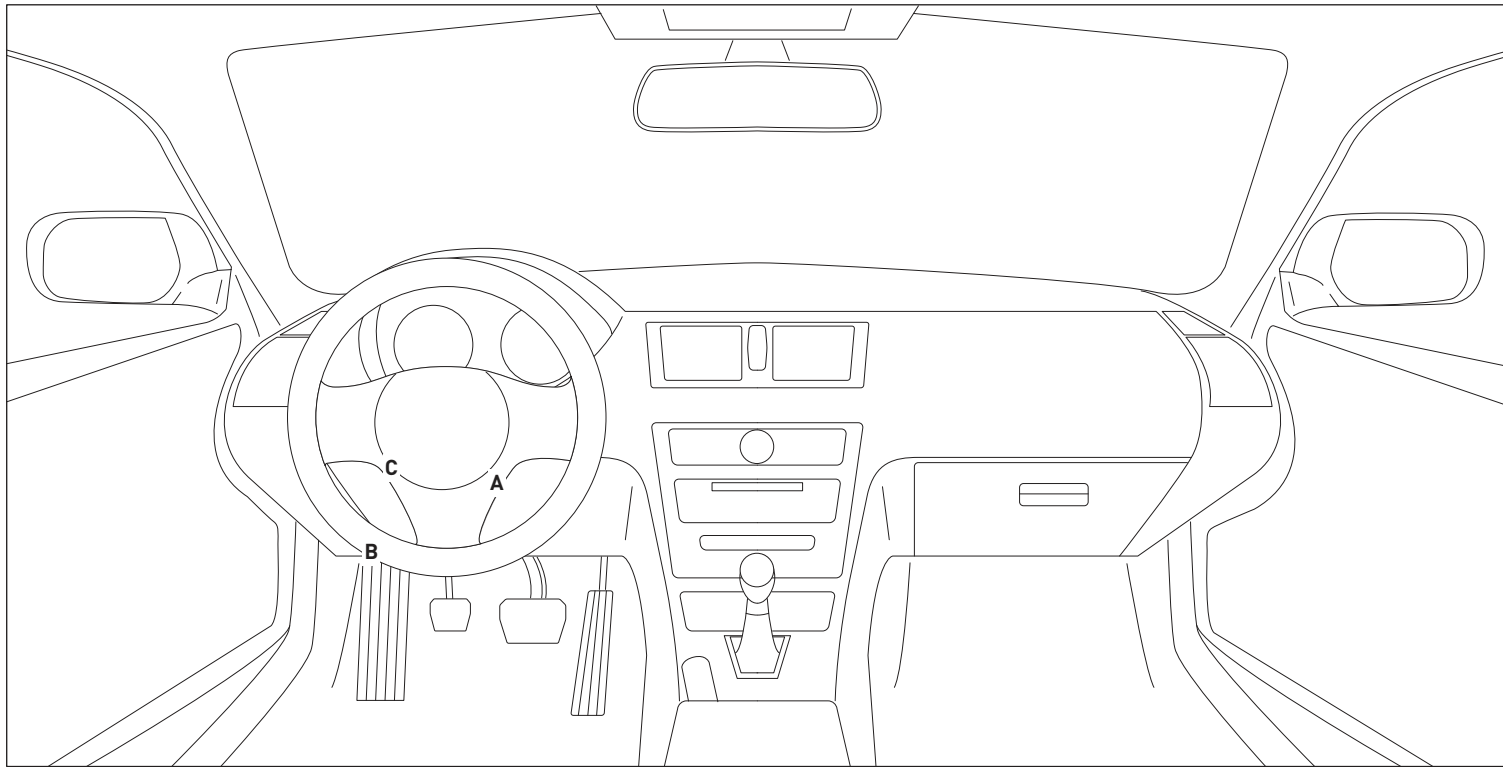

- CUT LOOP FOR AUTOMATIC TRANSMISSION ONLY
- SOME PARTS OF THE T-HARNESS (MS4-C, MS2-A, VS3/VS4 AND JS8) ARE NOT USED IN THIS INSTALL DO NOT CONNECT THEM.
- JS7 IS NOT USED IF THE VEHICLE IS EQUIPPED WITH AN IMMOBILIZER

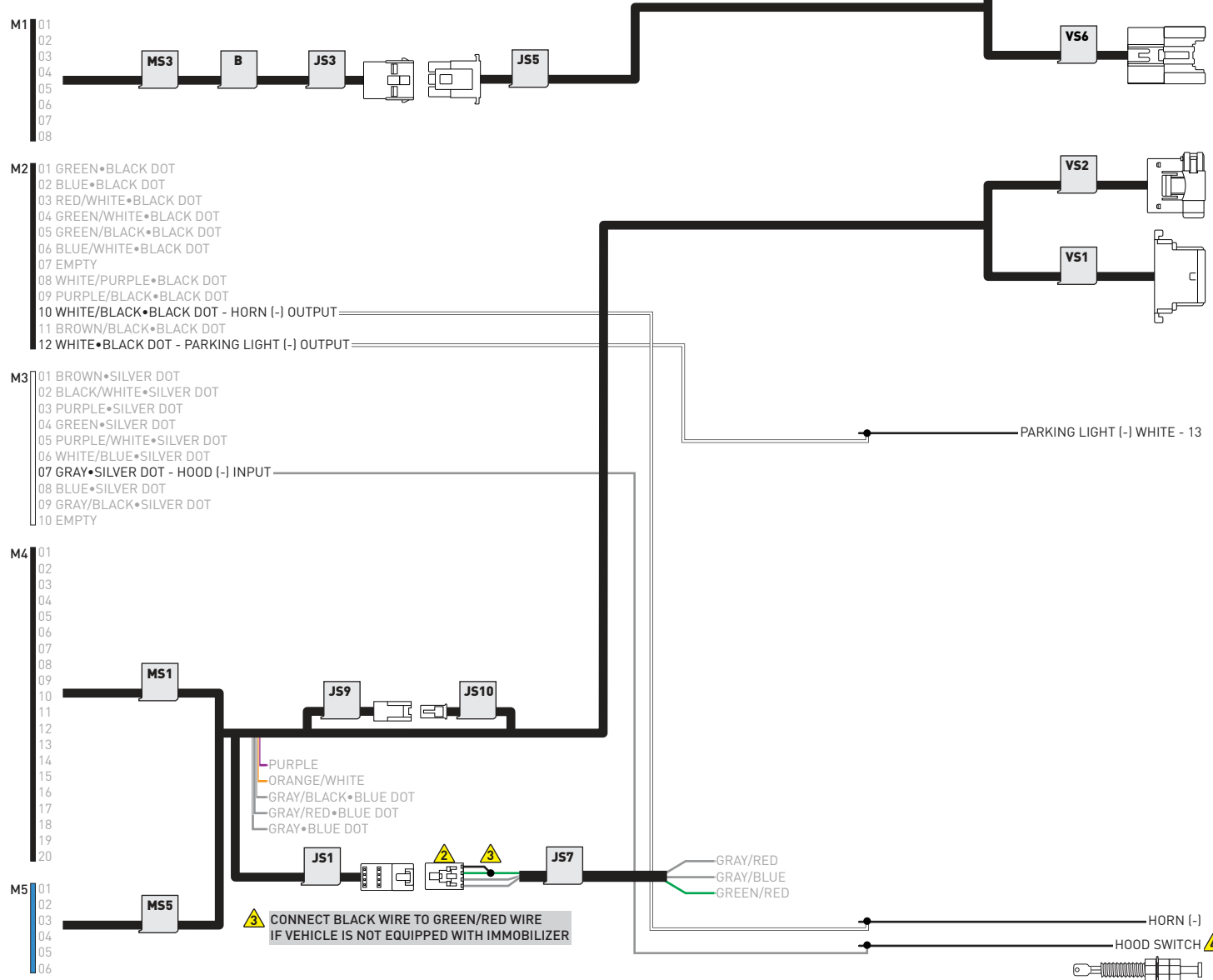

CONNECT BLACK WIRE TO GREEN/RED WIRE IF VEHICLE IS NOT EQUIPPED WITH IMMOBILIZER

IF NOT EQUIPPED WITH AN OEM HOOD PIN: - INSTALL THE SUPPLIED HOOD SWITCH.
- CHANGE REMOTE STARTER INPUT CONFIGURATION (MENU #7) "4- HOOD INPUT SOURCE" TO "1- ANALOG".

IGNITION SWITCH (A)

1: IGNITION CONNECTOR

1: IGNITION HARNESS

OBDII (B)

1: OBDII CONNECTOR

1: OBDII HOLDER

PARKING LIGHT SWITCH (C)

1: WHITE

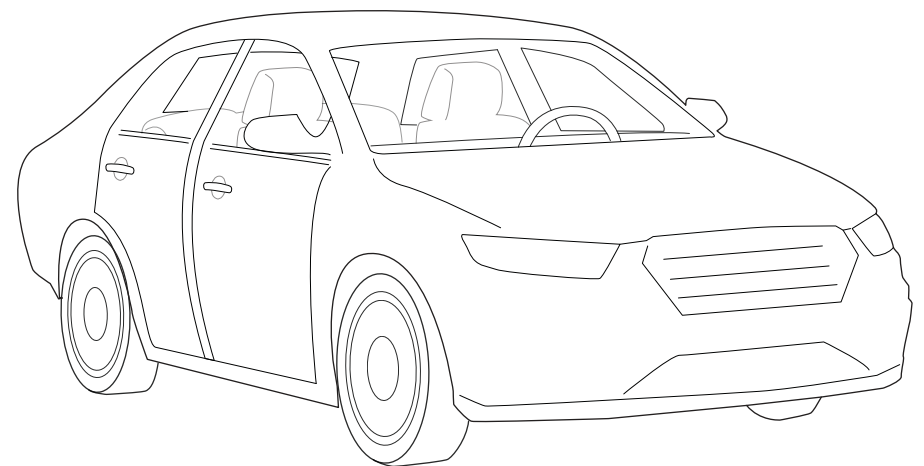
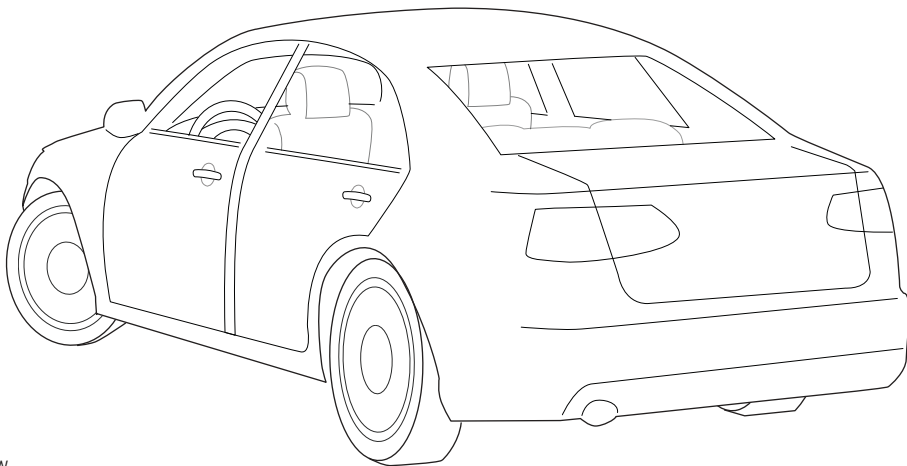
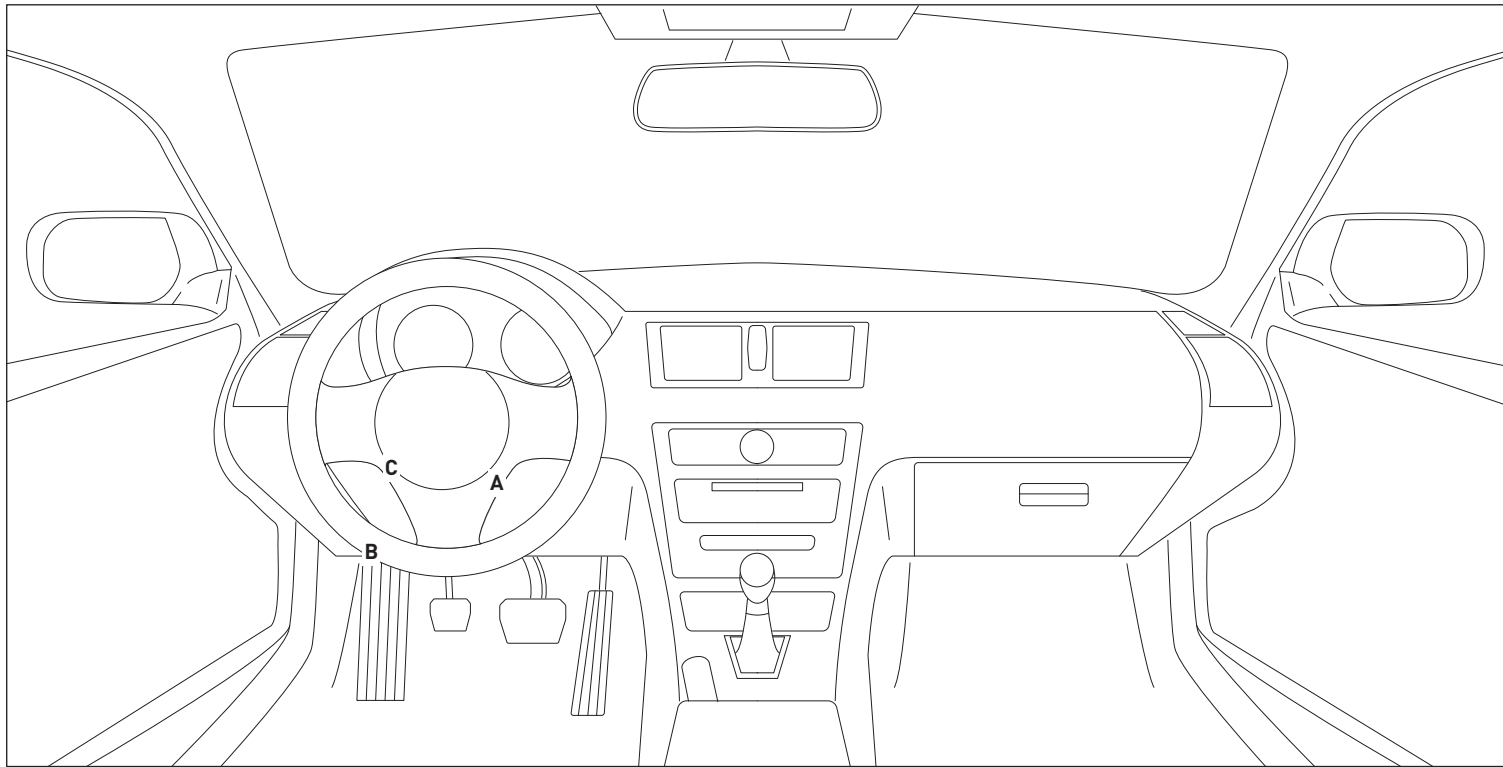

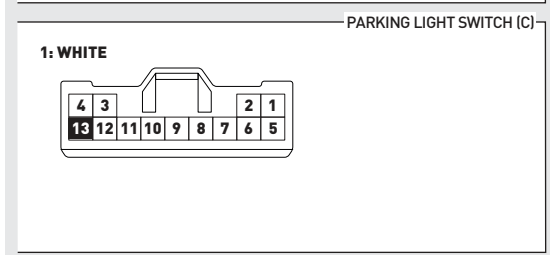
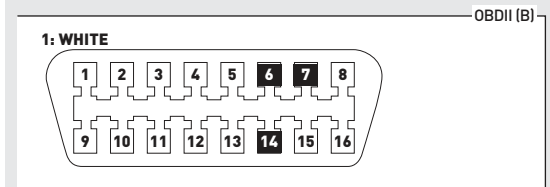
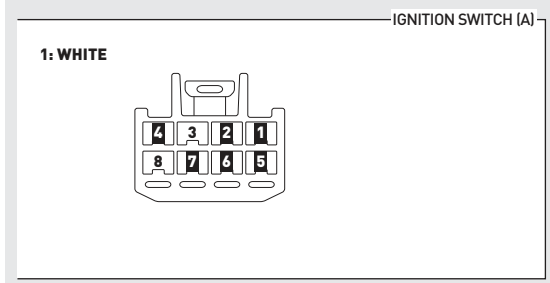
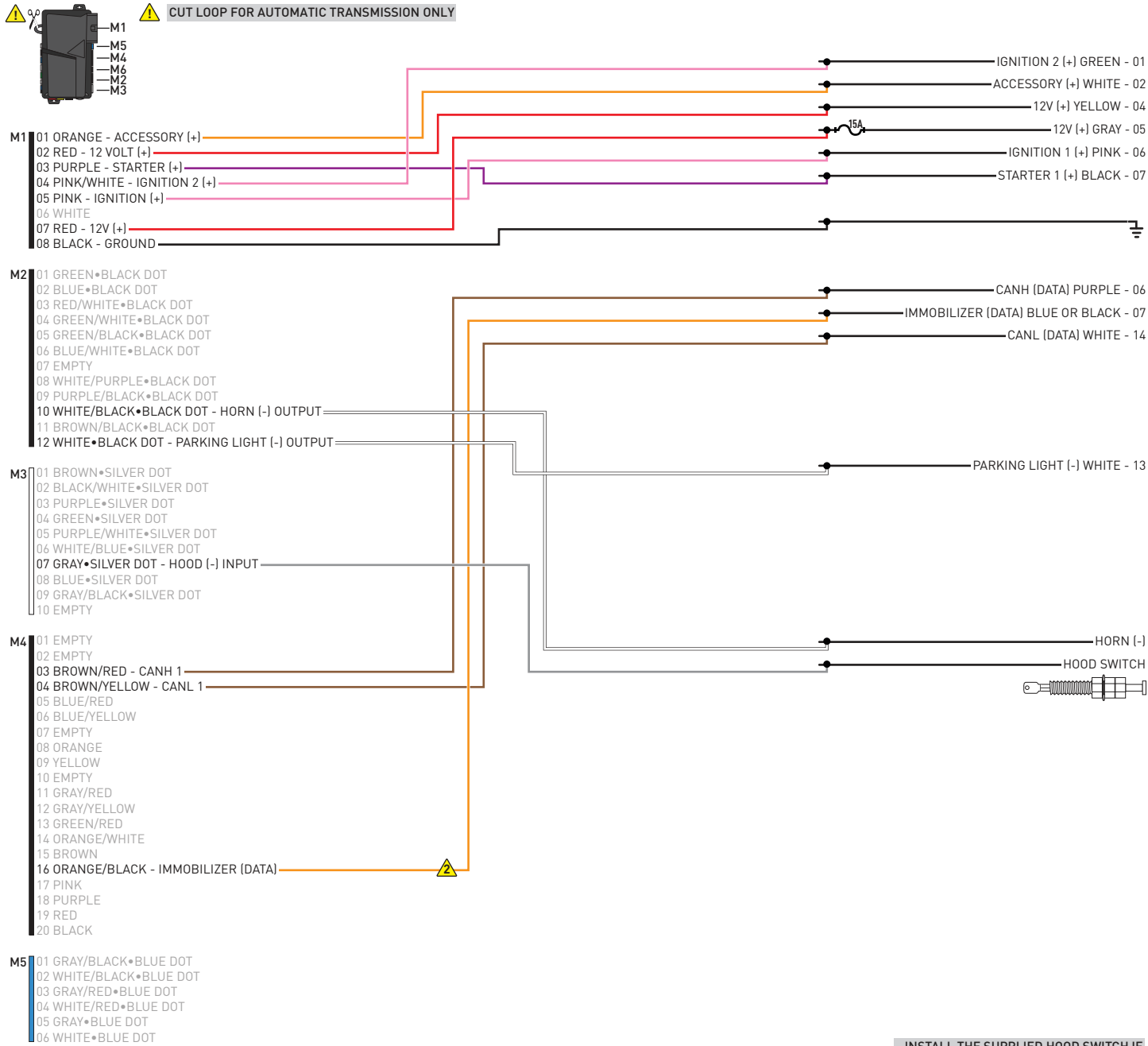

⚠ INSTALL THE SUPPLIED HOOD SWITCH IF THE VEHICLE IS NOT EQUIPPED WITH ONE.

⚠ CONNECT ORANGE/BLACK WIRE TO GROUND IF VEHICLE IS NOT EQUIPPED WITH IMMOBILIZER

01  Use the BLACK key only. DO NOT use the GRAY valet key.

02  Turn key to ON position.

03  Wait, LED 1 will turn solid GREEN for 2 seconds.

04  Turn key to OFF position.

05  START vehicle for 15 seconds.

06  Press and hold the brake pedal.

07  Press and release the module's programming button.

08  Release the brake pedal.

09  Wait, LED 2 will flash GREEN.

10  Module Programming Procedure completed.

>>



All vehicle doors must be closed and locked prior to remote start sequence.

01



Press unlock on OEM or aftermarket remote or request switch.

02



DO NOT PRESS BRAKE PEDAL. Set ignition to ON position. Wait 2 seconds for key validation.

03



Press and release BRAKE pedal.

04



Take over procedure completed.

>>



Failure to follow procedure will result in vehicle engine shutdown.

CHECKLIST - WITH AFTERMARKET KEYFOB

1	WARNING: Vehicle engine will start many times. Test in a well ventilated area.
2	Close all vehicle doors, hood and trunk.
3	Press the LOCK button once [1x] on the aftermarket keyfob.
	Question 1: Do the doors lock?
<input type="checkbox"/>	YES: Go to next step.
<input type="checkbox"/>	NO: Verify the remote programming, the RF connections and the wired door lock/unlock connections as illustrated in the wiring diagram, if applicable. Repeat the test and call technical support, if the problem persists.
4	Press the UNLOCK button once [1x] on the aftermarket keyfob.
	Question 2: Do the doors unlock?
<input type="checkbox"/>	YES: Go to next step.
<input type="checkbox"/>	NO: Verify the remote programming, the RF connections and the wired door lock/unlock connections as illustrated in the wiring diagram, if applicable. Repeat the test and call technical support, if the problem persists.
5	Press the TRUNK release button once [1x] on the aftermarket keyfob if supported.
	Question 3: Does the trunk or hatch open/unlock?
<input type="checkbox"/>	YES: Close trunk or hatch and go to next step.
<input type="checkbox"/>	NO: Verify the remote programming, the RF connections and the wired trunk/hatch connections as illustrated in the wiring diagram, if applicable. Repeat the test and call technical support, if the problem persists.
6	Press the AUX 1 button once [1x] on the aftermarket keyfob if supported.
	Question 4: Does the driver side sliding door open?
<input type="checkbox"/>	YES: Press the AUX 1 button once [1x] to close the driver sliding door and go to next step.
<input type="checkbox"/>	NO: Verify the remote programming and the RF connections. Repeat the test and call technical support, if the problem persists.
7	Press the AUX 2 button once [1x] on the aftermarket keyfob if supported.
	Question 5: Does the passenger side sliding door open?
<input type="checkbox"/>	YES: Press the AUX 2 button once [1x] to close the passenger sliding door and go to next step.
<input type="checkbox"/>	NO: Verify the remote programming and the RF connections. Repeat the test and call technical support, if the problem persists.
8	Press the START/STOP button once [1x] on the aftermarket keyfob to remote start vehicle.
	Question 6: Does the vehicle remote start?
<input type="checkbox"/>	YES: Go to next step.
<input type="checkbox"/>	NO: Verify the remote programming, the RF connections and check the remote start error codes. Repeat the test and call technical support, if the problem persists.

9	Press the START/STOP button once [1x] on the aftermarket keyfob to shut down vehicle.
	Question 7: Does the vehicle shut down?
<input type="checkbox"/>	YES: Go to next step.
<input type="checkbox"/>	NO: Repeat step. If problem persists, press the brake pedal once [1x] to shut down the vehicle and call technical support.
10	RAP and auto light shutdown test
	Question 8: Did the radio, interior controls and headlights turn off within 60 seconds after remote start shutdown?
<input type="checkbox"/>	YES: Go to next step.
<input type="checkbox"/>	NO: Verify the RAP SHUTDOWN connections as illustrated in the wiring diagram. Repeat the test and call technical support if the problem persists.
11	Open hood.
12	If not already installed, affix the mandatory orange warning sticker under the hood and proceed to next step.
13	Press the START/STOP button once [1x] on the aftermarket keyfob to remote start vehicle.
	Question 9: Does the vehicle remote start?
<input type="checkbox"/>	YES: The vehicle is not equipped with a factory hood pin. Install a mandatory aftermarket hood switch, then repeat the test.
<input type="checkbox"/>	NO: Go to next step.
14	Close hood.
15	Enter vehicle and close the doors.
16	Press the START/STOP button once [1x] on the aftermarket keyfob to remote start vehicle.
17	Wait for the vehicle to start.
18	Press brake pedal.
	Question 10: Does the vehicle shut down?
<input type="checkbox"/>	YES: Go to next step.
<input type="checkbox"/>	NO: The module does NOT detect the brake pedal signal. Press the START/STOP button once [1x] on the aftermarket keyfob to shut down vehicle, check connection as illustrated in the wiring diagram, if applicable, and call technical support.
19	Exit vehicle.
20	Installation checklist completed.

CHECKLIST - WITH OEM KEYFOB	
1	WARNING: Vehicle engine will start many times. Test in a well ventilated area.
2	Close all vehicle doors, hood and trunk.
3	Press LOCK button three times [3x] rapidly on the OEM keyfob to remote start vehicle.
	Question 1: Does the vehicle remote start?
<input type="checkbox"/>	YES: Go to next step.
<input type="checkbox"/>	NO: The module doesn't detect OEM remote lock button from the vehicle communication network. Check all connections, repeat the test and call technical support, if the problem persists.
4	Press LOCK button three times [3x] rapidly on the OEM keyfob to shut down vehicle.
	Question 2: Does the vehicle shut down?
<input type="checkbox"/>	YES: Go to next step.
<input type="checkbox"/>	NO: Repeat step. If the problem persists, press on the brake pedal once [1x] to shut down the vehicle and call technical support.
5	RAP Shutdown test
	Question 3: Did the radio, interior controls, and headlights turn off within 60 seconds after remote start shutdown?
<input type="checkbox"/>	YES: Go to next step.
<input type="checkbox"/>	NO: Verify the RAP SHUTDOWN connections as illustrated in the wiring diagram. Repeat the test and call technical support, if the problem persists.
6	Open hood.
7	If not already installed, affix the mandatory orange warning sticker under the hood and proceed to next step.
8	Press LOCK button three times [3x] rapidly on the OEM keyfob to remote start vehicle.
	Question 4: Does the vehicle remote start?
<input type="checkbox"/>	YES: The vehicle is not equipped with a factory hood pin. Install a mandatory aftermarket hood switch, then repeat the test.
<input type="checkbox"/>	NO: Go to next step.
9	Close hood.
10	Enter vehicle and close the doors.
11	Press LOCK button three times [3x] rapidly on the OEM keyfob to remote start vehicle.
12	Wait for the vehicle to start.
13	Press brake pedal.
	Question 5: Does the vehicle shut down?
<input type="checkbox"/>	YES: Go to next step.
<input type="checkbox"/>	NO: The module does NOT detect the brake pedal signal. Press LOCK button three times [3x] rapidly on the OEM keyfob to shut down, check the brake connection as illustrated in the wiring diagram, if applicable, and call technical support.
14	Exit vehicle.
15	Installation checklist completed.

COMPUSTAR®

INSTALL GUIDE

2011 TOYOTA YARIS HATCHBACK 80-BIT STD KEY AT

DOCUMENT NUMBER

REVISION DATE

20180926

FIRMWARE

COM-RSA-TL5-[RS1B-DC3]

HARDWARE

RS1B-DC3

ACCESSORIES

ATTENTION: TO COMPLETE THIS INSTALLATION SOME ACCESSORIES MAY BE REQUIRED.
VISIT OUR WEBSITE TO SEE ALL THE REQUIRED ACCESSORIES FOR YOUR VEHICLE.

TERMS OF USE

Automotive Data Solutions Inc. ("ADS") products are strictly intended for installation by Certified Technicians who are employed by a registered business specialized in the installation of automotive aftermarket electronics products. Prior to beginning installation of an ADS product in a vehicle, it is the Certified Technician's responsibility to review the most current Product Guide, Install Guide and vehicle-specific notes available in Weblink®. ADS is not responsible for any damages whatsoever, including but not limited to any consequential damages, incidental damages, damages for loss of time, loss of earnings, loss of profit, commercial loss, loss of economic opportunity and the like that may or may not have resulted from the use, misuse, improper installation or operation of its products. ADS reserves itself the right to suspend any Weblink® account without notice and decline to offer technical support to non-Certified Technicians, non-compliant Certified Technicians or end users.



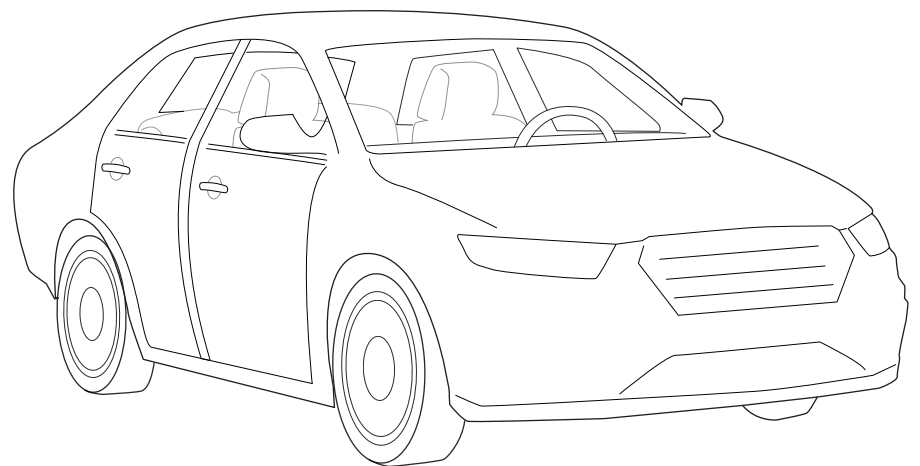
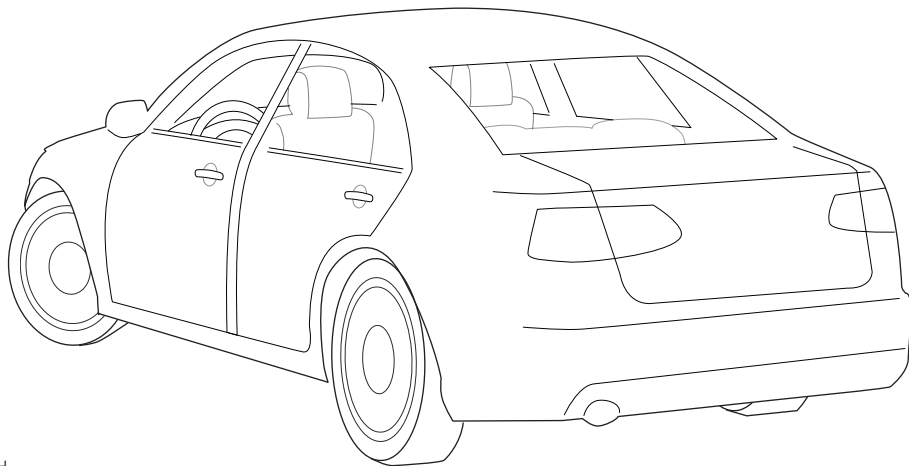
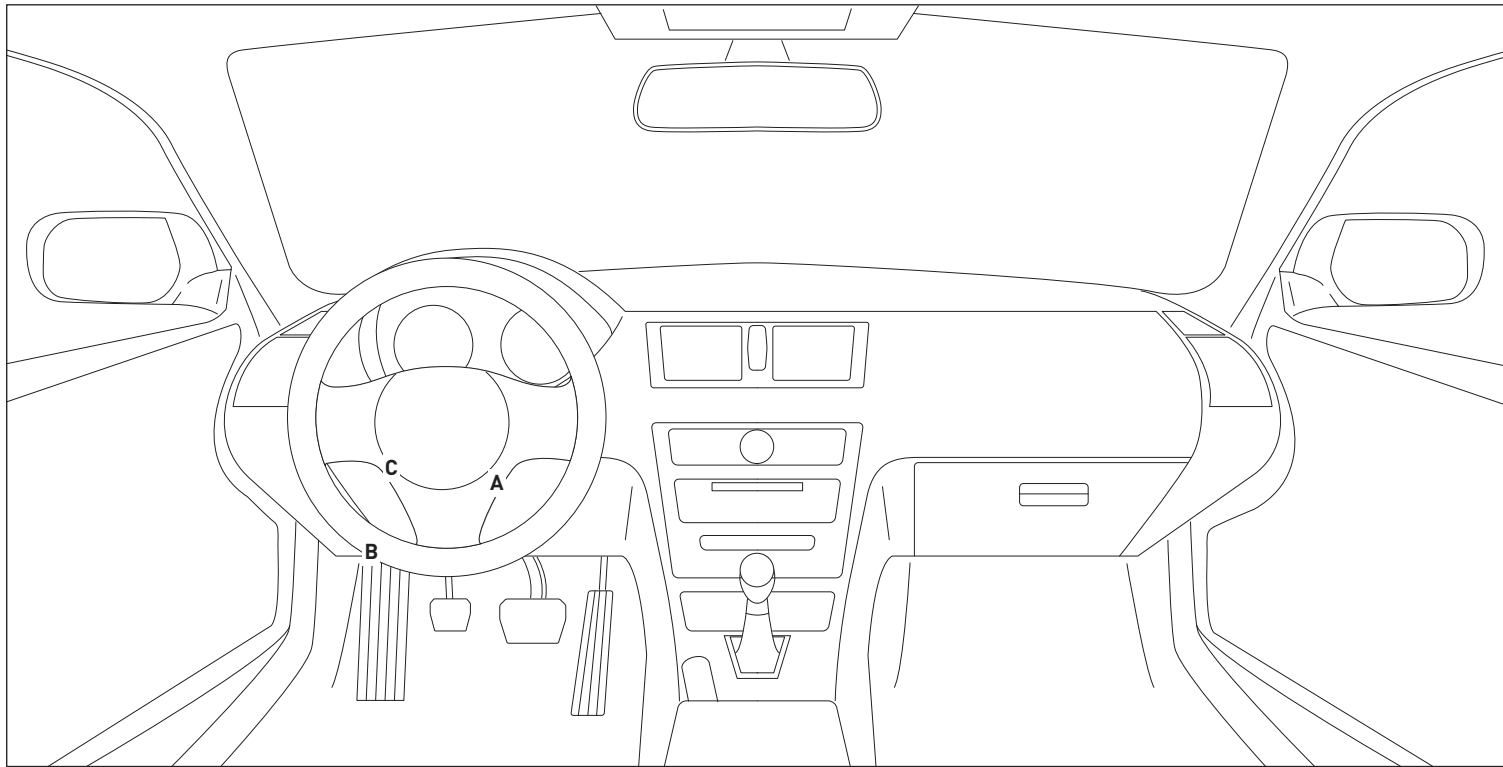

- CUT LOOP FOR AUTOMATIC TRANSMISSION ONLY
- SOME PARTS OF THE T-HARNESS (MS4-C, MS2-A, VS3/VS4 AND JS8) ARE NOT USED IN THIS INSTALL DO NOT CONNECT THEM.
- JS7 IS NOT USED IF THE VEHICLE IS EQUIPPED WITH AN IMMOBILIZER

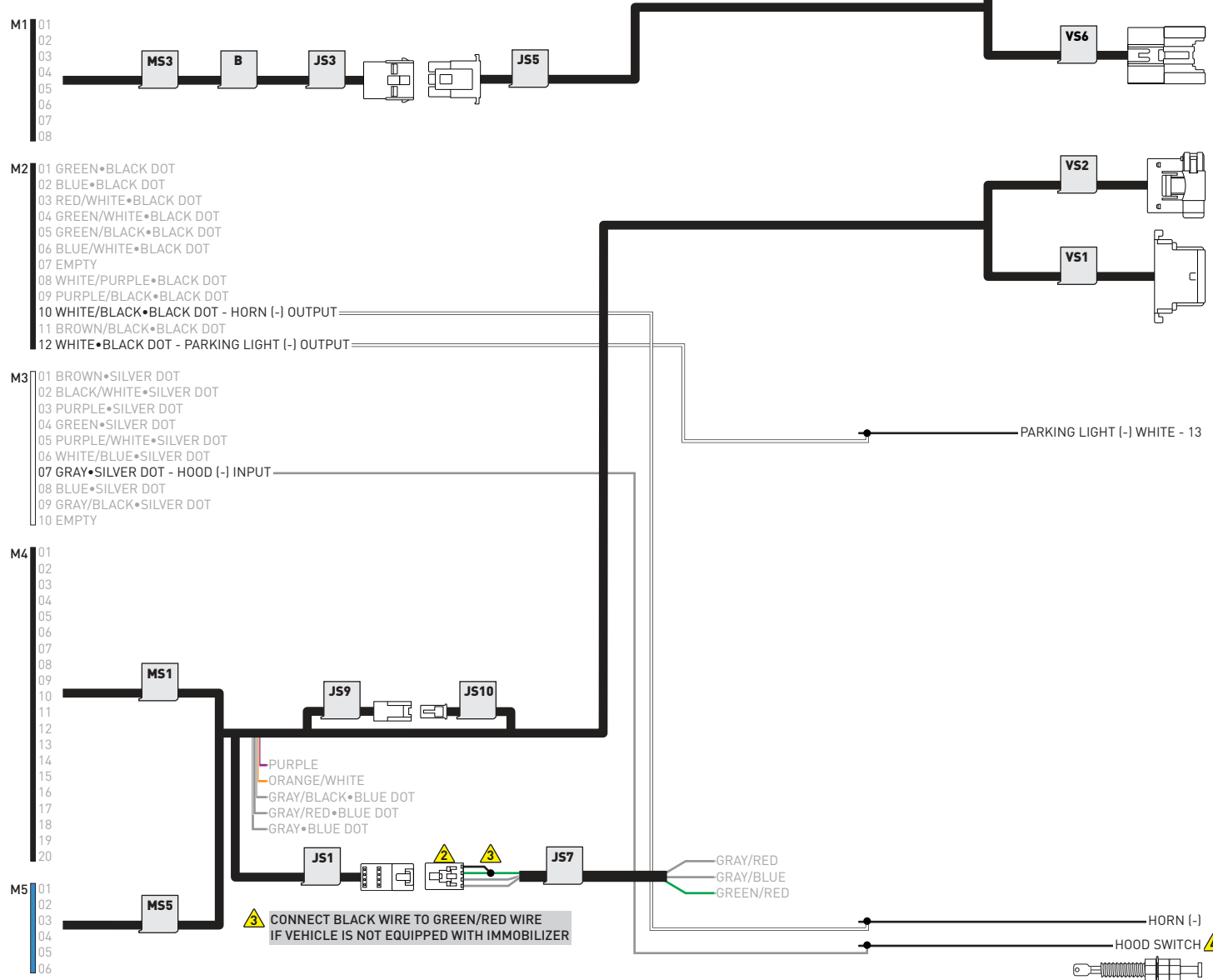

CONNECT BLACK WIRE TO GREEN/RED WIRE IF VEHICLE IS NOT EQUIPPED WITH IMMOBILIZER

IF NOT EQUIPPED WITH AN OEM HOOD PIN: - INSTALL THE SUPPLIED HOOD SWITCH.
- CHANGE REMOTE STARTER INPUT CONFIGURATION (MENU #7) "4- HOOD INPUT SOURCE" TO "1- ANALOG".

IGNITION SWITCH (A)

1: IGNITION CONNECTOR

1: IGNITION HARNESS

OBDII (B)

1: OBDII CONNECTOR

1: OBDII HOLDER

PARKING LIGHT SWITCH (C)

1: WHITE

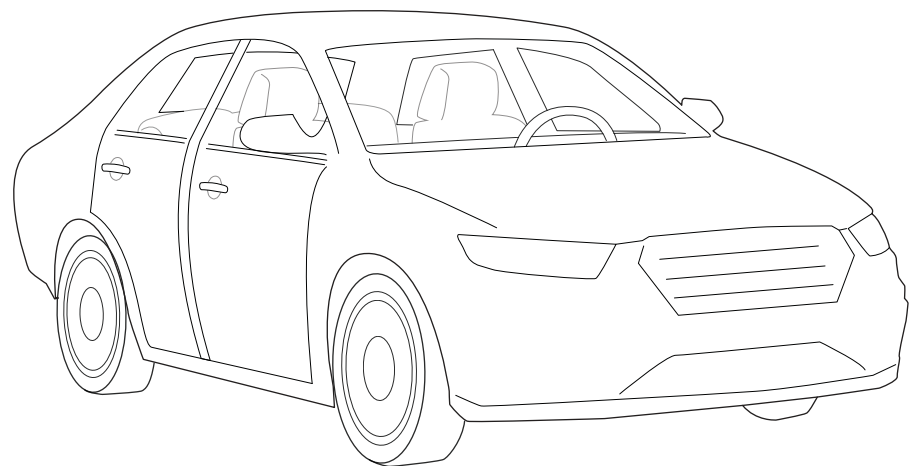
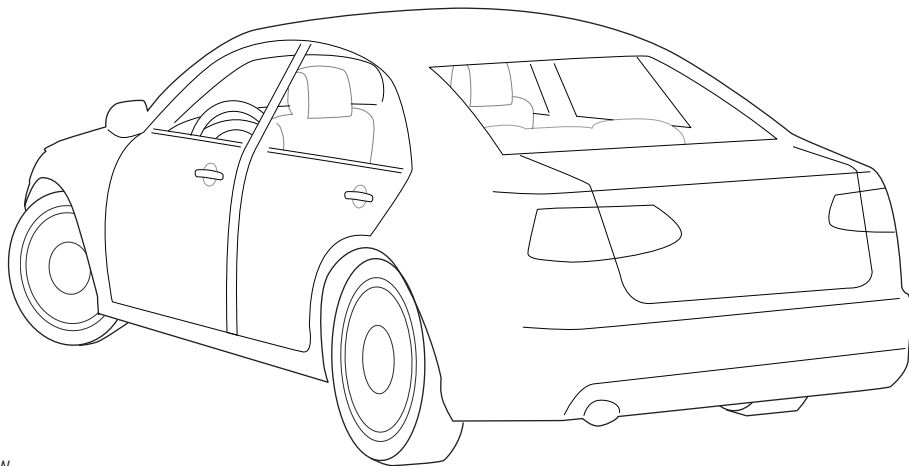
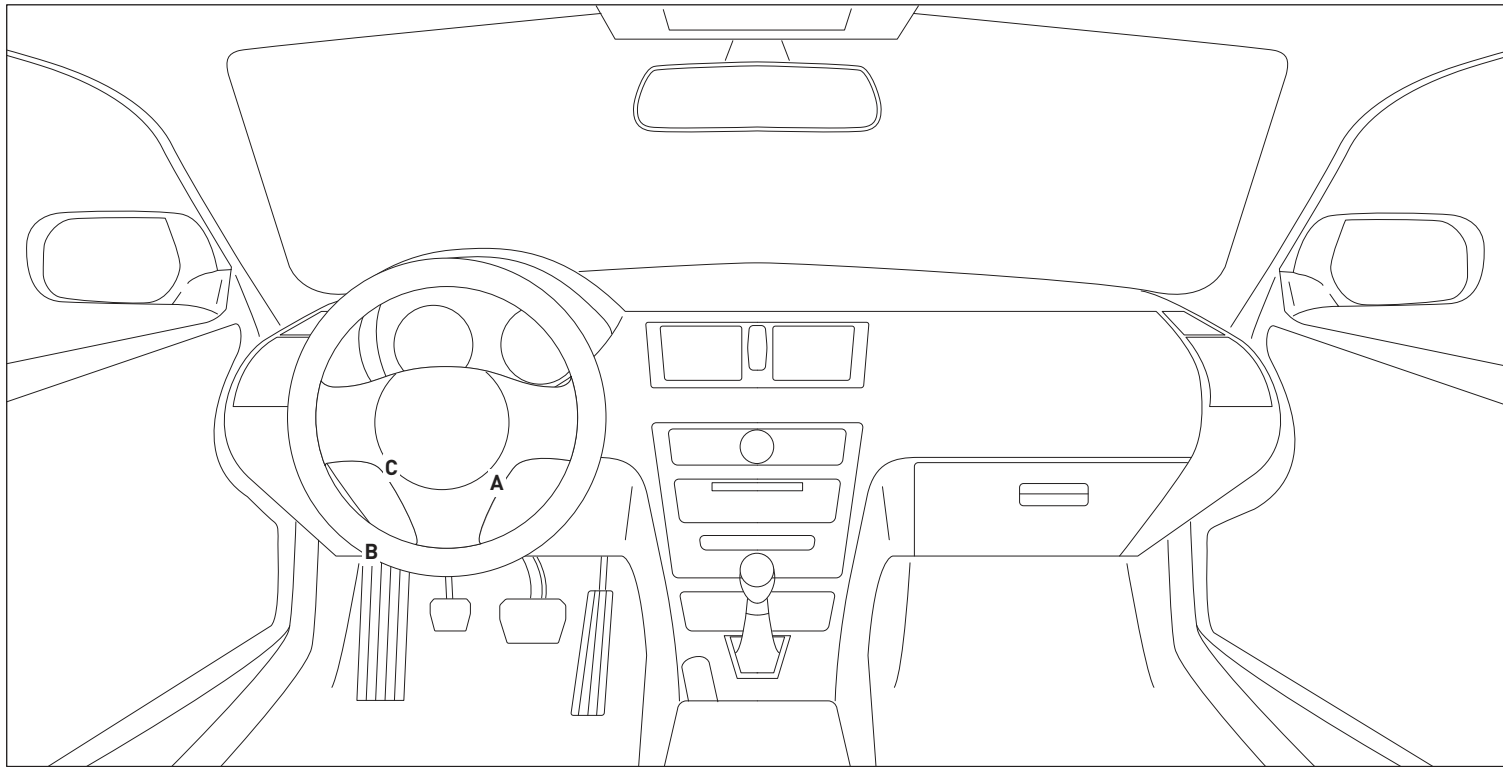

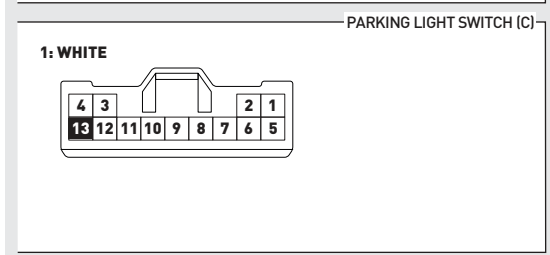
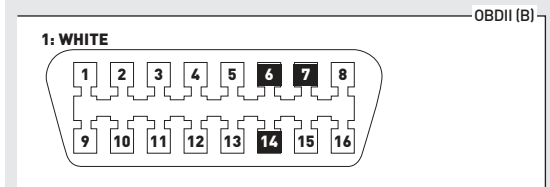
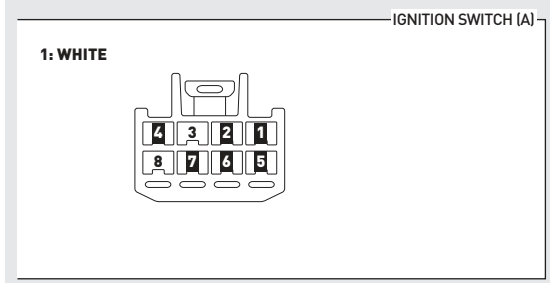
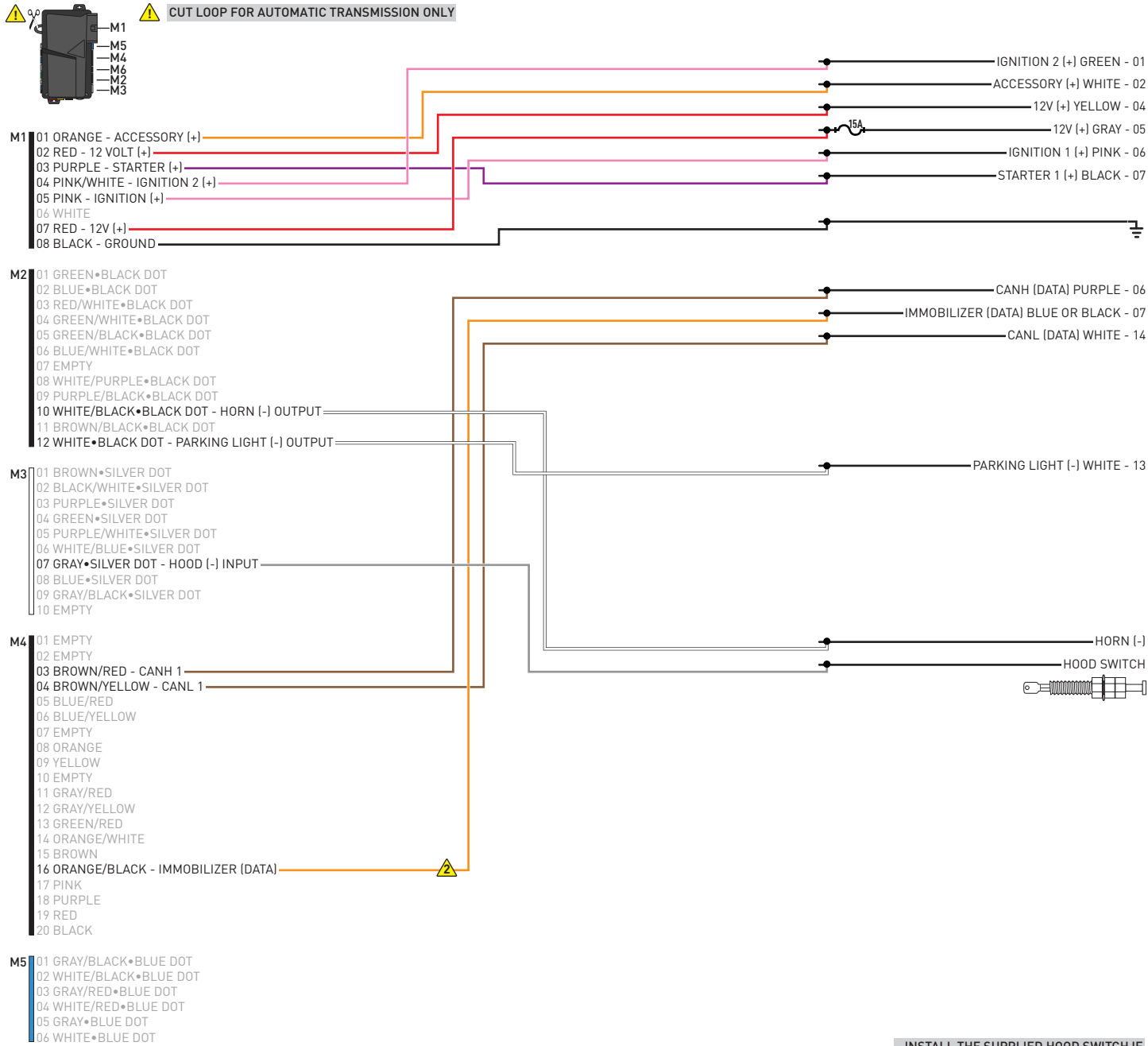

⚠ INSTALL THE SUPPLIED HOOD SWITCH IF THE VEHICLE IS NOT EQUIPPED WITH ONE.

⚠ CONNECT ORANGE/BLACK WIRE TO GROUND IF VEHICLE IS NOT EQUIPPED WITH IMMOBILIZER

01  Use the BLACK key only. DO NOT use the GRAY valet key.

02  Turn key to ON position.

03  Wait, LED 1 will turn solid GREEN for 2 seconds.

04  Turn key to OFF position.

05  START vehicle for 15 seconds.

06  Press and hold the brake pedal.

07  Press and release the module's programming button.

08  Release the brake pedal.

09  Wait, LED 2 will flash GREEN.

10  Module Programming Procedure completed.

>>



All vehicle doors must be closed and locked prior to remote start sequence.

01



Press unlock on OEM or aftermarket remote or request switch.

02



DO NOT PRESS BRAKE PEDAL. Set ignition to ON position. Wait 2 seconds for key validation.

03



Press and release BRAKE pedal.

04



Take over procedure completed.

>>



Failure to follow procedure will result in vehicle engine shutdown.

CHECKLIST - WITH AFTERMARKET KEYFOB

1	WARNING: Vehicle engine will start many times. Test in a well ventilated area.	9	Press the START/STOP button once [1x] on the aftermarket keyfob to shut down vehicle.
2	Close all vehicle doors, hood and trunk.		Question 7: Does the vehicle shut down?
3	Press the LOCK button once [1x] on the aftermarket keyfob.	<input type="checkbox"/>	YES: Go to next step.
	Question 1: Do the doors lock?	<input type="checkbox"/>	NO: Repeat step. If problem persists, press the brake pedal once [1x] to shut down the vehicle and call technical support.
<input type="checkbox"/>	YES: Go to next step.	10	RAP and auto light shutdown test
<input type="checkbox"/>	NO: Verify the remote programming, the RF connections and the wired door lock/unlock connections as illustrated in the wiring diagram, if applicable. Repeat the test and call technical support, if the problem persists.		Question 8: Did the radio, interior controls and headlights turn off within 60 seconds after remote start shutdown?
4	Press the UNLOCK button once [1x] on the aftermarket keyfob.	<input type="checkbox"/>	YES: Go to next step.
	Question 2: Do the doors unlock?	<input type="checkbox"/>	NO: Verify the RAP SHUTDOWN connections as illustrated in the wiring diagram. Repeat the test and call technical support if the problem persists.
<input type="checkbox"/>	YES: Go to next step.	11	Open hood.
<input type="checkbox"/>	NO: Verify the remote programming, the RF connections and the wired door lock/unlock connections as illustrated in the wiring diagram, if applicable. Repeat the test and call technical support, if the problem persists.	12	If not already installed, affix the mandatory orange warning sticker under the hood and proceed to next step.
5	Press the TRUNK release button once [1x] on the aftermarket keyfob if supported.	13	Press the START/STOP button once [1x] on the aftermarket keyfob to remote start vehicle.
	Question 3: Does the trunk or hatch open/unlock?		Question 9: Does the vehicle remote start?
<input type="checkbox"/>	YES: Close trunk or hatch and go to next step.	<input type="checkbox"/>	YES: The vehicle is not equipped with a factory hood pin. Install a mandatory aftermarket hood switch, then repeat the test.
<input type="checkbox"/>	NO: Verify the remote programming, the RF connections and the wired trunk/hatch connections as illustrated in the wiring diagram, if applicable. Repeat the test and call technical support, if the problem persists.	<input type="checkbox"/>	NO: Go to next step.
6	Press the AUX 1 button once [1x] on the aftermarket keyfob if supported.	14	Close hood.
	Question 4: Does the driver side sliding door open?	15	Enter vehicle and close the doors.
<input type="checkbox"/>	YES: Press the AUX 1 button once [1x] to close the driver sliding door and go to next step.	16	Press the START/STOP button once [1x] on the aftermarket keyfob to remote start vehicle.
<input type="checkbox"/>	NO: Verify the remote programming and the RF connections. Repeat the test and call technical support, if the problem persists.	17	Wait for the vehicle to start.
7	Press the AUX 2 button once [1x] on the aftermarket keyfob if supported.	18	Press brake pedal.
	Question 5: Does the passenger side sliding door open?		Question 10: Does the vehicle shut down?
<input type="checkbox"/>	YES: Press the AUX 2 button once [1x] to close the passenger sliding door and go to next step.	<input type="checkbox"/>	YES: Go to next step.
<input type="checkbox"/>	NO: Verify the remote programming and the RF connections. Repeat the test and call technical support, if the problem persists.	<input type="checkbox"/>	NO: The module does NOT detect the brake pedal signal. Press the START/STOP button once [1x] on the aftermarket keyfob to shut down vehicle, check connection as illustrated in the wiring diagram, if applicable, and call technical support.
8	Press the START/STOP button once [1x] on the aftermarket keyfob to remote start vehicle.	19	Exit vehicle.
	Question 6: Does the vehicle remote start?	20	Installation checklist completed.
<input type="checkbox"/>	YES: Go to next step.		
<input type="checkbox"/>	NO: Verify the remote programming, the RF connections and check the remote start error codes. Repeat the test and call technical support, if the problem persists.		

CHECKLIST - WITH OEM KEYFOB	
1	WARNING: Vehicle engine will start many times. Test in a well ventilated area.
2	Close all vehicle doors, hood and trunk.
3	Press LOCK button three times [3x] rapidly on the OEM keyfob to remote start vehicle.
	Question 1: Does the vehicle remote start?
<input type="checkbox"/>	YES: Go to next step.
<input type="checkbox"/>	NO: The module doesn't detect OEM remote lock button from the vehicle communication network. Check all connections, repeat the test and call technical support, if the problem persists.
4	Press LOCK button three times [3x] rapidly on the OEM keyfob to shut down vehicle.
	Question 2: Does the vehicle shut down?
<input type="checkbox"/>	YES: Go to next step.
<input type="checkbox"/>	NO: Repeat step. If the problem persists, press on the brake pedal once [1x] to shut down the vehicle and call technical support.
5	RAP Shutdown test
	Question 3: Did the radio, interior controls, and headlights turn off within 60 seconds after remote start shutdown?
<input type="checkbox"/>	YES: Go to next step.
<input type="checkbox"/>	NO: Verify the RAP SHUTDOWN connections as illustrated in the wiring diagram. Repeat the test and call technical support, if the problem persists.
6	Open hood.
7	If not already installed, affix the mandatory orange warning sticker under the hood and proceed to next step.
8	Press LOCK button three times [3x] rapidly on the OEM keyfob to remote start vehicle.
	Question 4: Does the vehicle remote start?
<input type="checkbox"/>	YES: The vehicle is not equipped with a factory hood pin. Install a mandatory aftermarket hood switch, then repeat the test.
<input type="checkbox"/>	NO: Go to next step.
9	Close hood.
10	Enter vehicle and close the doors.
11	Press LOCK button three times [3x] rapidly on the OEM keyfob to remote start vehicle.
12	Wait for the vehicle to start.
13	Press brake pedal.
	Question 5: Does the vehicle shut down?
<input type="checkbox"/>	YES: Go to next step.
<input type="checkbox"/>	NO: The module does NOT detect the brake pedal signal. Press LOCK button three times [3x] rapidly on the OEM keyfob to shut down, check the brake connection as illustrated in the wiring diagram, if applicable, and call technical support.
14	Exit vehicle.
15	Installation checklist completed.

COMPUSTAR®

INSTALL GUIDE

2012-2014 TOYOTA YARIS HATCHBACK 80-BIT STD KEY AT

DOCUMENT NUMBER

REVISION DATE

20180926

FIRMWARE

COM-RSA-TL5-[RS1B-DC3]

HARDWARE

RS1B-DC3

ACCESSORIES

ATTENTION: TO COMPLETE THIS INSTALLATION SOME ACCESSORIES MAY BE REQUIRED.
VISIT OUR WEBSITE TO SEE ALL THE REQUIRED ACCESSORIES FOR YOUR VEHICLE.

TERMS OF USE

Automotive Data Solutions Inc. ("ADS") products are strictly intended for installation by Certified Technicians who are employed by a registered business specialized in the installation of automotive aftermarket electronics products. Prior to beginning installation of an ADS product in a vehicle, it is the Certified Technician's responsibility to review the most current Product Guide, Install Guide and vehicle-specific notes available in Weblink®. ADS is not responsible for any damages whatsoever, including but not limited to any consequential damages, incidental damages, damages for loss of time, loss of earnings, loss of profit, commercial loss, loss of economic opportunity and the like that may or may not have resulted from the use, misuse, improper installation or operation of its products. ADS reserves itself the right to suspend any Weblink® account without notice and decline to offer technical support to non-Certified Technicians, non-compliant Certified Technicians or end users.



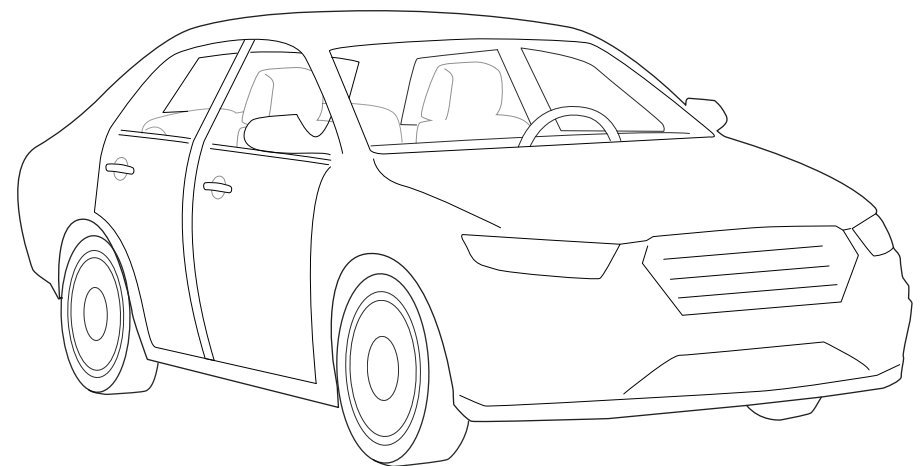
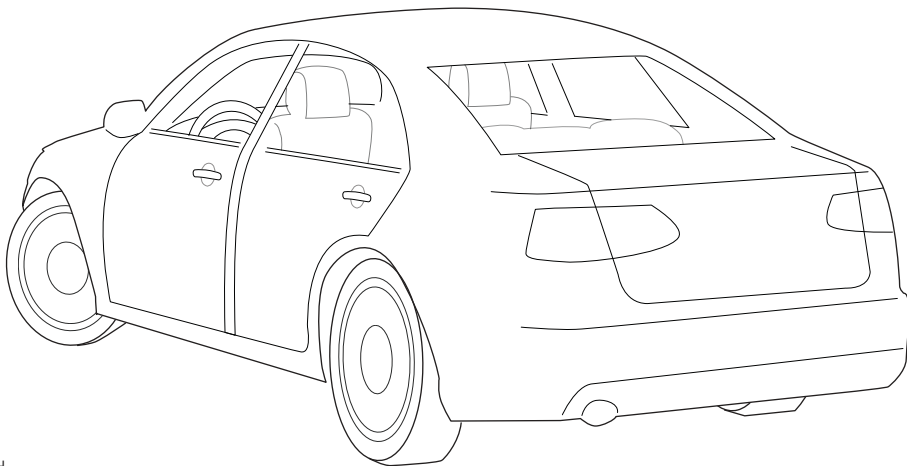
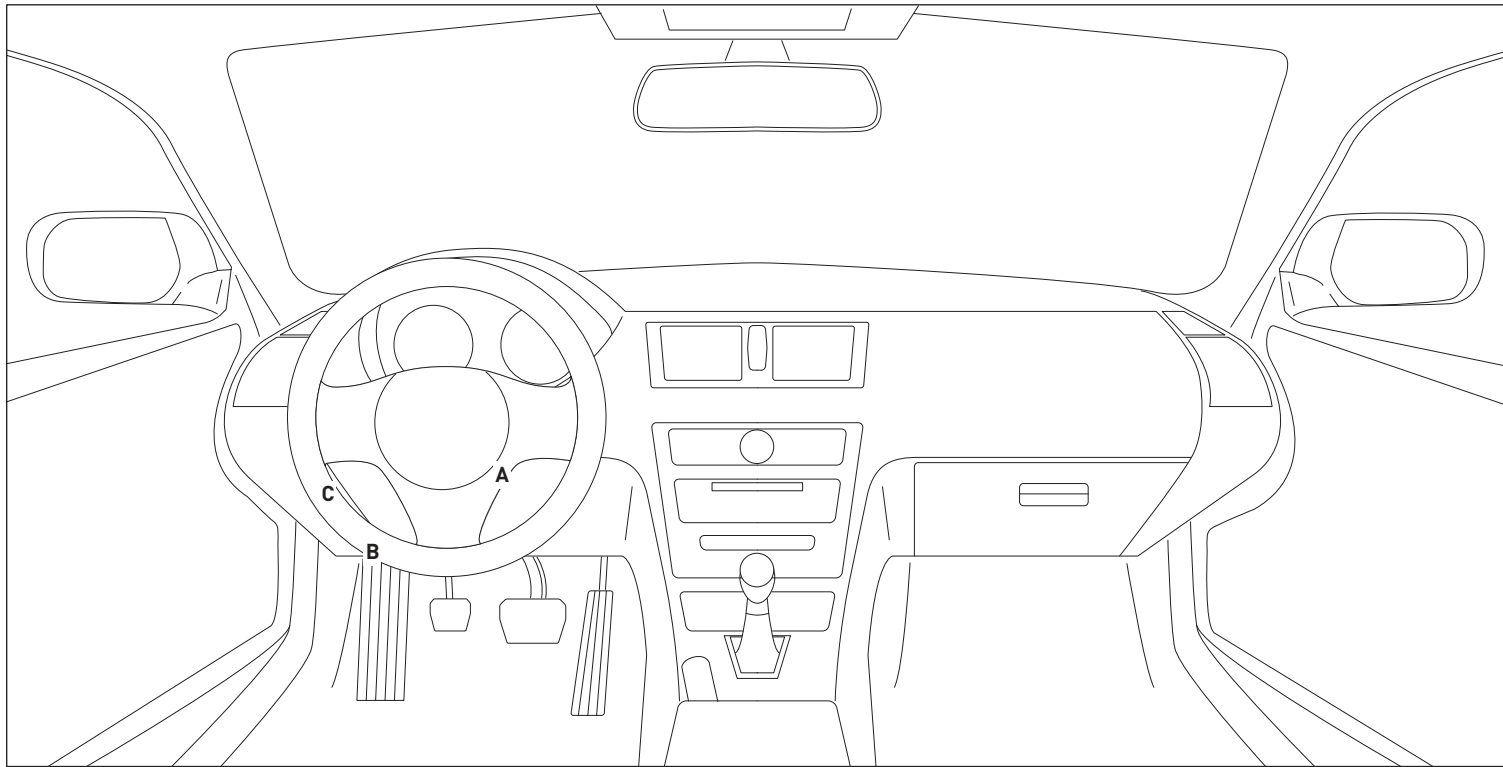

- CUT LOOP FOR AUTOMATIC TRANSMISSION ONLY
- SOME PARTS OF THE T-HARNESS (MS4-C, MS2-A, VS3/VS4 AND JS8) ARE NOT USED IN THIS INSTALL DO NOT CONNECT THEM.
- JS7 IS NOT USED IF THE VEHICLE IS EQUIPPED WITH AN IMMOBILIZER

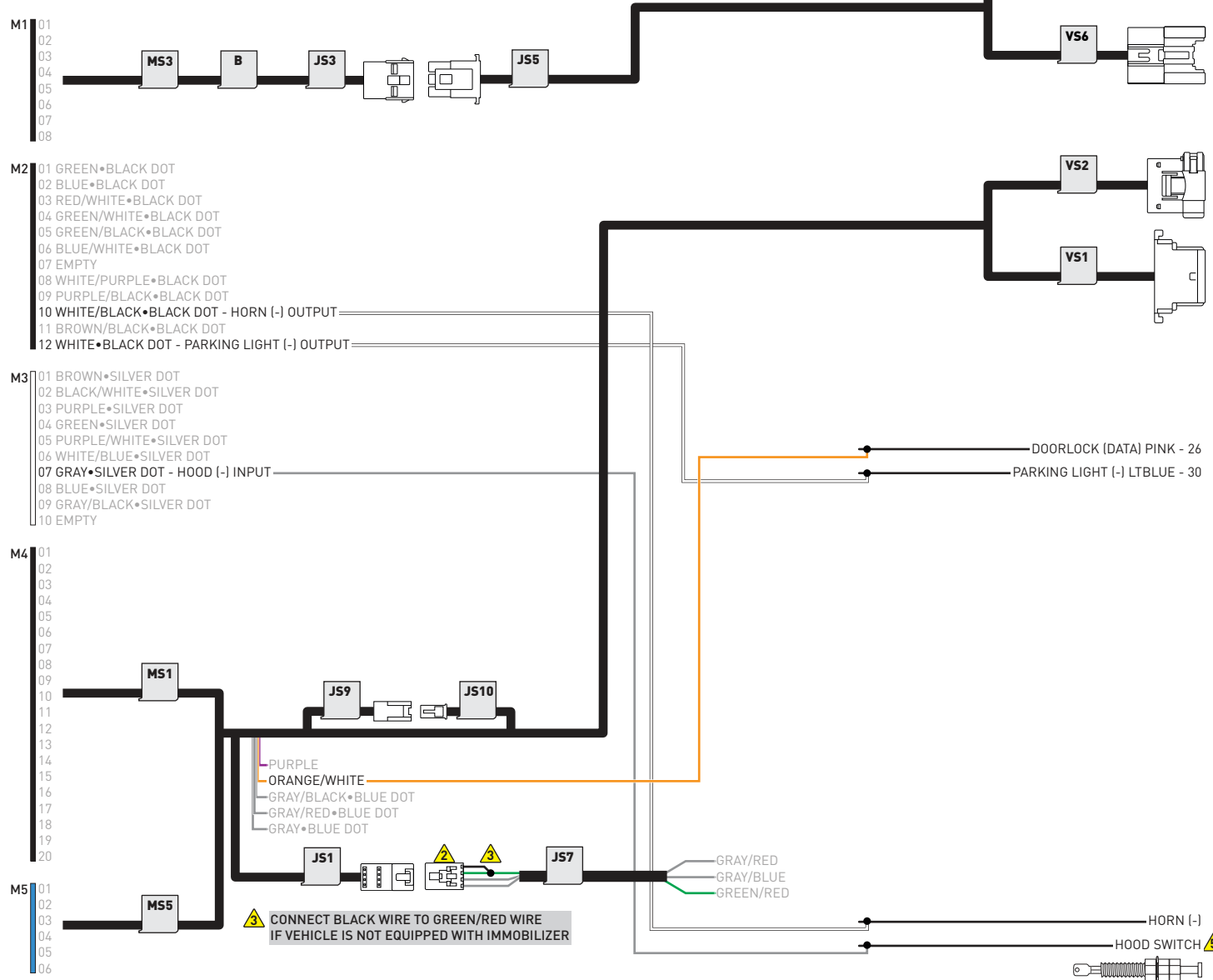

3 CONNECT BLACK WIRE TO GREEN/RED WIRE IF VEHICLE IS NOT EQUIPPED WITH IMMOBILIZER

5 IF NOT EQUIPPED WITH AN OEM HOOD PIN:
 - INSTALL THE SUPPLIED HOOD SWITCH.
 - CHANGE REMOTE STARTER INPUT CONFIGURATION (MENU #7) "4- HOOD INPUT SOURCE" TO "1- ANALOG".

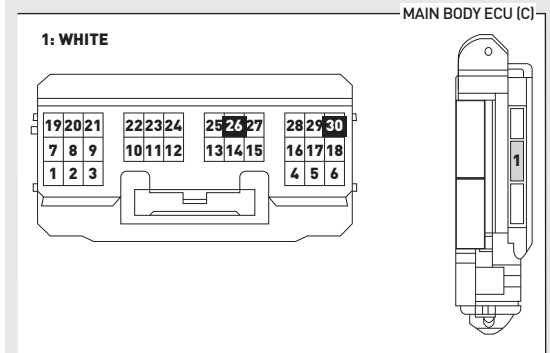
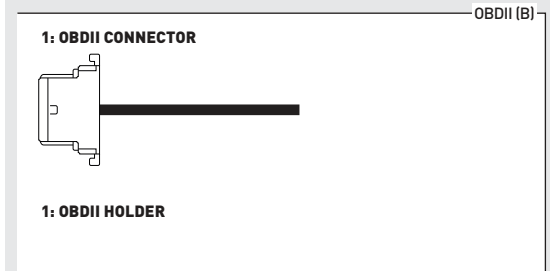
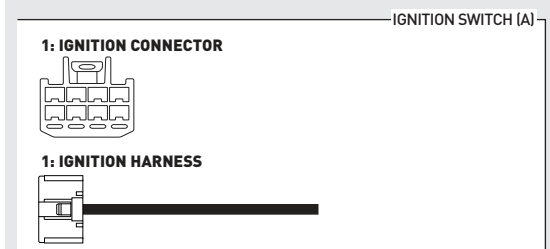

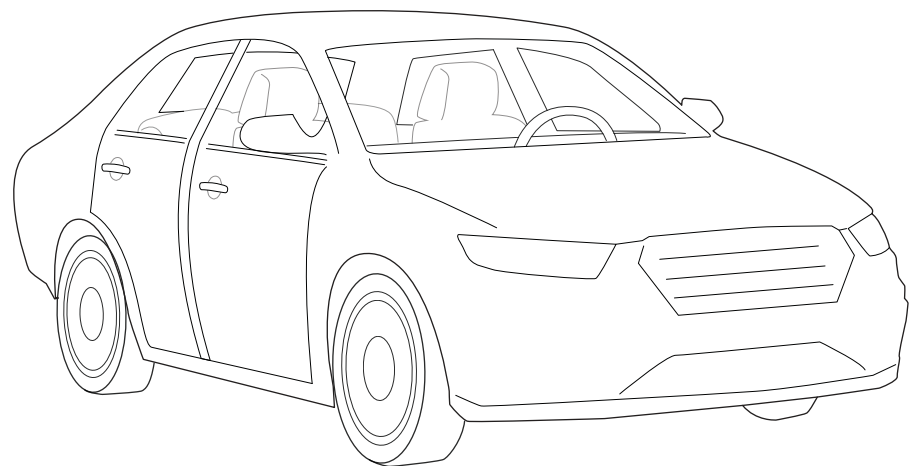
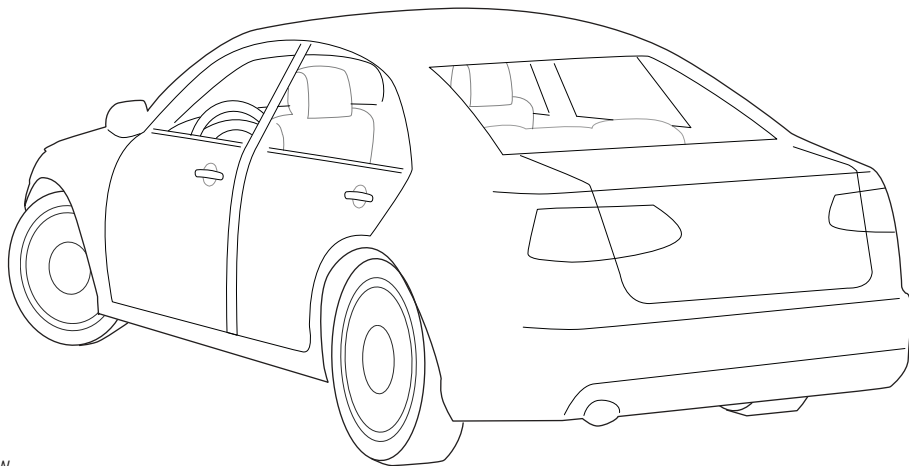
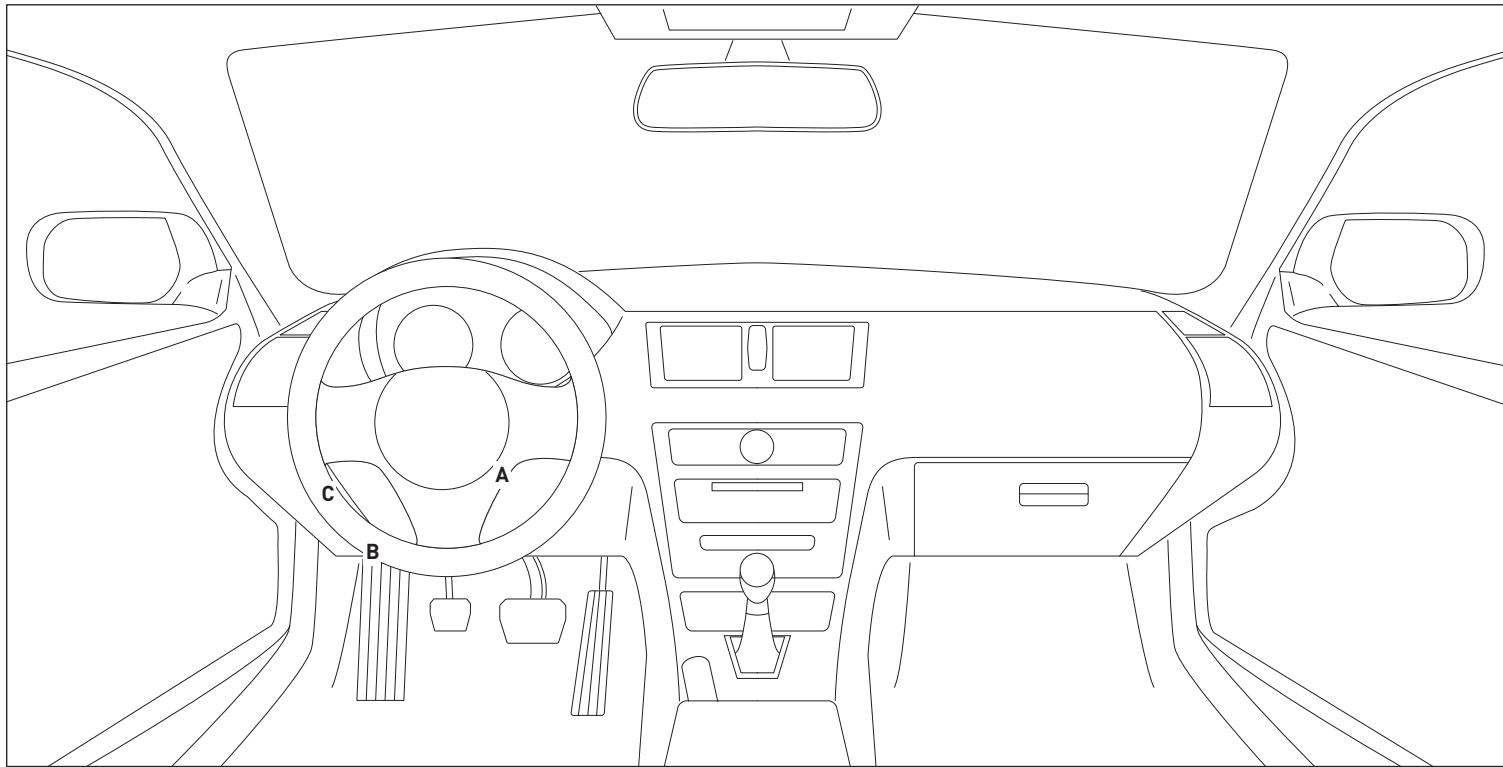

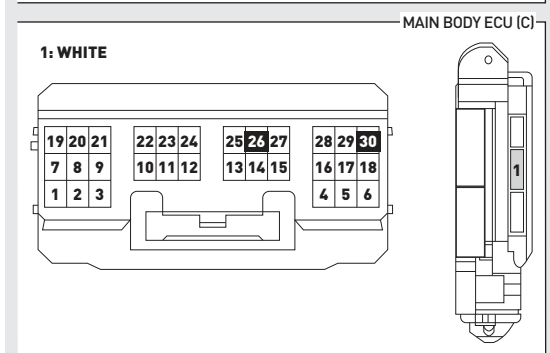
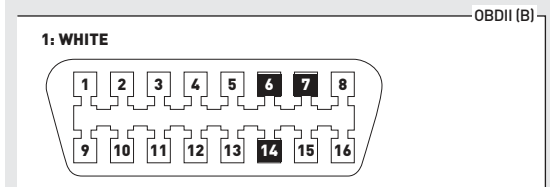
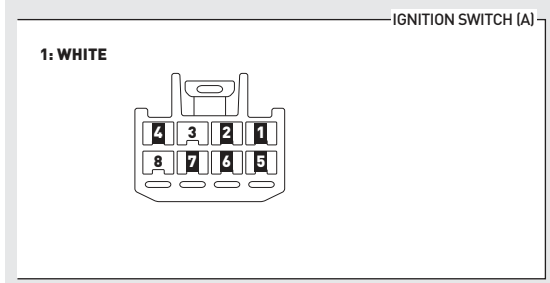
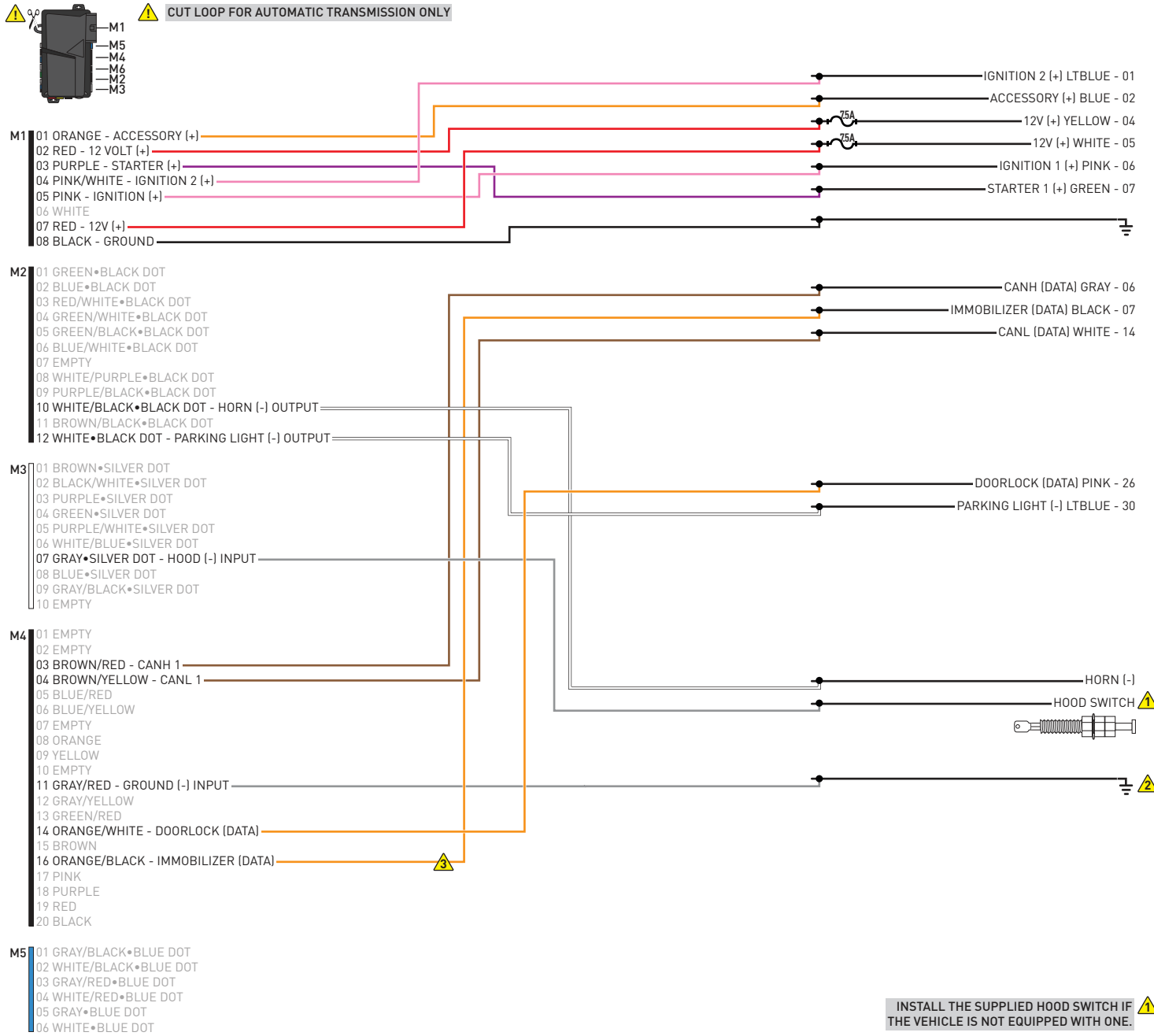

⚠ INSTALL THE SUPPLIED HOOD SWITCH IF THE VEHICLE IS NOT EQUIPPED WITH ONE.

⚠ WITHOUT OEM HOOD STATUS ONLY

⚠ CONNECT ORANGE/BLACK WIRE TO GROUND IF VEHICLE IS NOT EQUIPPED WITH IMMOBILIZER.

01  Use the BLACK key only. DO NOT use the GRAY valet key.

02  Turn key to ON position.

03  Wait, LED 1 will turn solid GREEN for 2 seconds.

04  Turn key to OFF position.

05  START vehicle for 15 seconds.

06  Press and hold the brake pedal.

07  Press and release the module's programming button.

08  Release the brake pedal.

09  Wait, LED 2 will flash GREEN.

10  Module Programming Procedure completed.

>>



All vehicle doors must be closed and locked prior to remote start sequence.

01



Press unlock on OEM or aftermarket remote or request switch.

02



DO NOT PRESS BRAKE PEDAL. Set ignition to ON position. Wait 2 seconds for key validation.

03



Press and release BRAKE pedal.

04



Take over procedure completed.

>>



Failure to follow procedure will result in vehicle engine shutdown.

CHECKLIST - WITH AFTERMARKET KEYFOB

1	WARNING: Vehicle engine will start many times. Test in a well ventilated area.
2	Close all vehicle doors, hood and trunk.
3	Press the LOCK button once [1x] on the aftermarket keyfob.
	Question 1: Do the doors lock?
<input type="checkbox"/>	YES: Go to next step.
<input type="checkbox"/>	NO: Verify the remote programming, the RF connections and the wired door lock/unlock connections as illustrated in the wiring diagram, if applicable. Repeat the test and call technical support, if the problem persists.
4	Press the UNLOCK button once [1x] on the aftermarket keyfob.
	Question 2: Do the doors unlock?
<input type="checkbox"/>	YES: Go to next step.
<input type="checkbox"/>	NO: Verify the remote programming, the RF connections and the wired door lock/unlock connections as illustrated in the wiring diagram, if applicable. Repeat the test and call technical support, if the problem persists.
5	Press the TRUNK release button once [1x] on the aftermarket keyfob if supported.
	Question 3: Does the trunk or hatch open/unlock?
<input type="checkbox"/>	YES: Close trunk or hatch and go to next step.
<input type="checkbox"/>	NO: Verify the remote programming, the RF connections and the wired trunk/hatch connections as illustrated in the wiring diagram, if applicable. Repeat the test and call technical support, if the problem persists.
6	Press the AUX 1 button once [1x] on the aftermarket keyfob if supported.
	Question 4: Does the driver side sliding door open?
<input type="checkbox"/>	YES: Press the AUX 1 button once [1x] to close the driver sliding door and go to next step.
<input type="checkbox"/>	NO: Verify the remote programming and the RF connections. Repeat the test and call technical support, if the problem persists.
7	Press the AUX 2 button once [1x] on the aftermarket keyfob if supported.
	Question 5: Does the passenger side sliding door open?
<input type="checkbox"/>	YES: Press the AUX 2 button once [1x] to close the passenger sliding door and go to next step.
<input type="checkbox"/>	NO: Verify the remote programming and the RF connections. Repeat the test and call technical support, if the problem persists.
8	Press the START/STOP button once [1x] on the aftermarket keyfob to remote start vehicle.
	Question 6: Does the vehicle remote start?
<input type="checkbox"/>	YES: Go to next step.
<input type="checkbox"/>	NO: Verify the remote programming, the RF connections and check the remote start error codes. Repeat the test and call technical support, if the problem persists.

9	Press the START/STOP button once [1x] on the aftermarket keyfob to shut down vehicle.
	Question 7: Does the vehicle shut down?
<input type="checkbox"/>	YES: Go to next step.
<input type="checkbox"/>	NO: Repeat step. If problem persists, press the brake pedal once [1x] to shut down the vehicle and call technical support.
10	RAP and auto light shutdown test
	Question 8: Did the radio, interior controls and headlights turn off within 60 seconds after remote start shutdown?
<input type="checkbox"/>	YES: Go to next step.
<input type="checkbox"/>	NO: Verify the RAP SHUTDOWN connections as illustrated in the wiring diagram. Repeat the test and call technical support if the problem persists.
11	Open hood.
12	If not already installed, affix the mandatory orange warning sticker under the hood and proceed to next step.
13	Press the START/STOP button once [1x] on the aftermarket keyfob to remote start vehicle.
	Question 9: Does the vehicle remote start?
<input type="checkbox"/>	YES: The vehicle is not equipped with a factory hood pin. Install a mandatory aftermarket hood switch, then repeat the test.
<input type="checkbox"/>	NO: Go to next step.
14	Close hood.
15	Enter vehicle and close the doors.
16	Press the START/STOP button once [1x] on the aftermarket keyfob to remote start vehicle.
17	Wait for the vehicle to start.
18	Press brake pedal.
	Question 10: Does the vehicle shut down?
<input type="checkbox"/>	YES: Go to next step.
<input type="checkbox"/>	NO: The module does NOT detect the brake pedal signal. Press the START/STOP button once [1x] on the aftermarket keyfob to shut down vehicle, check connection as illustrated in the wiring diagram, if applicable, and call technical support.
19	Exit vehicle.
20	Installation checklist completed.

CHECKLIST - WITH OEM KEYFOB	
1	WARNING: Vehicle engine will start many times. Test in a well ventilated area.
2	Close all vehicle doors, hood and trunk.
3	Press LOCK button three times [3x] rapidly on the OEM keyfob to remote start vehicle.
	Question 1: Does the vehicle remote start?
<input type="checkbox"/>	YES: Go to next step.
<input type="checkbox"/>	NO: The module doesn't detect OEM remote lock button from the vehicle communication network. Check all connections, repeat the test and call technical support, if the problem persists.
4	Press LOCK button three times [3x] rapidly on the OEM keyfob to shut down vehicle.
	Question 2: Does the vehicle shut down?
<input type="checkbox"/>	YES: Go to next step.
<input type="checkbox"/>	NO: Repeat step. If the problem persists, press on the brake pedal once [1x] to shut down the vehicle and call technical support.
5	RAP Shutdown test
	Question 3: Did the radio, interior controls, and headlights turn off within 60 seconds after remote start shutdown?
<input type="checkbox"/>	YES: Go to next step.
<input type="checkbox"/>	NO: Verify the RAP SHUTDOWN connections as illustrated in the wiring diagram. Repeat the test and call technical support, if the problem persists.
6	Open hood.
7	If not already installed, affix the mandatory orange warning sticker under the hood and proceed to next step.
8	Press LOCK button three times [3x] rapidly on the OEM keyfob to remote start vehicle.
	Question 4: Does the vehicle remote start?
<input type="checkbox"/>	YES: The vehicle is not equipped with a factory hood pin. Install a mandatory aftermarket hood switch, then repeat the test.
<input type="checkbox"/>	NO: Go to next step.
9	Close hood.
10	Enter vehicle and close the doors.
11	Press LOCK button three times [3x] rapidly on the OEM keyfob to remote start vehicle.
12	Wait for the vehicle to start.
13	Press brake pedal.
	Question 5: Does the vehicle shut down?
<input type="checkbox"/>	YES: Go to next step.
<input type="checkbox"/>	NO: The module does NOT detect the brake pedal signal. Press LOCK button three times [3x] rapidly on the OEM keyfob to shut down, check the brake connection as illustrated in the wiring diagram, if applicable, and call technical support.
14	Exit vehicle.
15	Installation checklist completed.